

AD 2 AERODROMES**WSSS SINGAPORE / SINGAPORE CHANGI INTL
WSSS AD 2.1 AERODROME LOCATION INDICATOR AND NAME****WSSS - SINGAPORE / SINGAPORE CHANGI INTL****WSSS AD 2.2 AERODROME GEOGRAPHICAL AND ADMINISTRATIVE DATA**

1	ARP coordinates and site at AD	012133.16N 1035921.57E (Control Tower)
2	Direction and distance from (city)	17.2km North-East from City Centre (The Fullerton Hotel, Singapore)
3	Elevation/Reference temperature	6.66m / 32.8 °C
4	Geoid Undulation (AD elevation position)	10.24 M
5	MAG VAR /Annual change	0°23' E (2020) / Negligible
6	AD Administration, address, telephone, telefax, AFS	CHANGI AIRPORT GROUP (SINGAPORE) PTE LTD Singapore Changi Airport P.O.Box 168, SINGAPORE 918146 Tel: (65)65956868
7	Types of traffic permitted	IFR
8	Remarks	a. Not available to all non-scheduled civil aircraft types of 40-seater or below except in special circumstances. Aircraft larger than the above category shall not plan their arrival between 0900-1559UTC. b. Aircraft shall leave nose-in position (90 degrees) with the aid of aircraft tow tractors. Reverse thrust or variable pitch propellers shall not be used. Aircraft operators shall make suitable arrangements. c. Prior permission required for aircraft not equipped with radiotelephony. d. A subsonic jet aircraft, unless otherwise exempted, is not permitted to operate in Singapore unless it possesses a noise certificate stating that it meets the noise standards of ICAO Annex 16, Volume 1, Chapter 3, or equivalent. The noise certificate may also take the form of a suitable statement contained in another document approved by the State of Registry of the aircraft. e. RVR minima for CATII ILS operations is limited to 350m due to runway and taxiway light spacing requirements on the airfield. f. Frangible poles are installed for the purpose of identifying 90m away from the centreline of RWY 02L/20R and RWY 02C/20C

WSSS AD 2.3 OPERATIONAL HOURS

Operational Hours		
1	Aerodrome Administration:	RWY 02L/20R RWY 02C/20C RWY 02R/20L H24
2	Customs and Immigration	H24
3	Health and Sanitation	H24
4	AIS Briefing Office	H24
5	ATS Reporting Office	H24
6	MET Briefing Office	H24
7	Air Traffic Services	H24

WSSS AD 2.4 HANDLING SERVICES AND FACILITIES

1	Cargo Handling Facilities	Cargo terminals equipped with advanced storage stacker, material and pallet container handling systems, computerised cargo information, data and documentation systems. By arrangement with airlines.
2	Fuel / Oil Types	JET A1(for aircraft). Oils: Various by arrangement with fuel companies.
3	Fuelling Facilities / Capacity	Hydrant refueling
4	Hangar space for visiting aircraft	By arrangement with SIA Engineering Company (SIAEC) or ST Aerospace Services Co.

5	<i>Repair facilities for visiting aircraft</i>	Maintenance and repairs for commercial aircraft up to and including A380 is by arrangement.
6	<i>Remarks</i>	a) Marshalling Service: No pilot shall taxi an aircraft on its own into a gate/stand without the aid of a docking system or a marshaller. b) Oxygen and related servicing: Oxygen for all cabin and aircraft system. No CO ₂ recharging facilities.

WSSS AD 2.5 PASSENGER FACILITIES

1	<i>Hotels</i>	Transit area and adjacent to airport terminal.
2	<i>Restaurants</i>	Transit and public areas of terminal building.
3	<i>Transportation</i>	Buses, taxis, MRT train and car rental service.
4	<i>Medical Facilities</i>	Available at airport.
5	<i>Bank and Post Office</i>	Available at airport.
6	<i>Tourist Office</i>	Available at airport.
7	<i>Remarks</i>	Internet address: http://www.changiairport.com.sg for airport and flight information, shops and restaurants, facilities and services, flight connections and tourist information.

WSSS AD 2.6 RESCUE AND FIRE FIGHTING SERVICES

1	<i>AD category for fire fighting</i>	<u>RWY 02L/20R, RWY 02C/20C and RWY 02R/20L</u> CAT10 (No facilities for foaming of runways)
2	<i>Rescue equipment</i>	Adequately provided as recommended by ICAO.
3	<i>Capability for removal of disabled aircraft</i>	Specialised aircraft recovery equipment available for up to and including A380 size aircraft operation.
4	<i>Remarks</i>	All Airport Emergency Service personnel are trained in rescue and fire-fighting as well as medical first-aid.

WSSS AD 2.7 SEASONAL AVAILABILITY - CLEARING

There is no requirement for clearing. The aerodrome is available throughout the year.

WSSS AD 2.8 APRONS, TAXIWAYS AND CHECK LOCATIONS/POSITIONS DATA

1	<i>Apron surface and strength</i>	Aircraft stands C11, C16, C19, D30, D35, D38, E2, E6, E7, E10, F32, F36, F37, 301, 303, 304, 305, 307, 308, 309, 402, 403, 404, 605, 952, G1 to G17 and 471 to 487 – Concrete surface; strength PCR 680/R/B/W/U Aircraft stand 306 – Concrete surface; strength PCR 784/R/B/W/U All other aircraft stands – Concrete surface; strength PCR 1006/R/B/W/U
---	-----------------------------------	---

		<p>Minimum width 23m for all taxiways</p> <p>TWY A1, A2, A11, A12, A (between A1 and A2, and between A11 and A12), B1, B2, B13, B14, B (between B1 and B2, and between B13 and B14), C1, C2, C13, C14, C (between C1 and C2) and L (between C13 and C14), D1, D2, D13, D14, D (between D1 and D2, and between D13 and D14), T1, T2, T4, T12, T13, T (between T11 and T13), U12, U13, U (between U12 and U13), W1, W9 – Concrete surface; strength PCR 1006/R/B/W/U</p> <p>TXL U2, TWY U7 (between TWY U and TXL U2), TWY U8 (between TWY U and TXL U2), TWY U9 (between TWY U and TXL U2), TXL S6, S8, S9, TWY S7 – Asphalt surface; strength PCR 530/F/B/X/U</p> <p>All other taxiways – Asphalt surface; strength PCR 710/F/B/X/U</p> <p><u>Note:</u> Open-air drains, demarcated by frangible poles, are installed within non-graded TWY strips at least 30m from the TWY centrelines. 0.5m-high lateral restraint at 30m east of TWY P8 and TXL N5 centreline before the open drain. 0.8m-high lateral restraints, located at 43m from the centreline of TWY G and TWY H, on the taxiway bridges.</p>
2	<i>Taxiway width, surface and strength</i>	
3	<i>Altimeter checkpoints location and elevation</i>	See AD-2-WSSS-ADC-2/ Chart (flip side) for coordinates and elevations of aircraft stands.
4	<i>VOR checkpoint location</i>	NIL
5	<i>INS checkpoints position</i>	See AD-2-WSSS-ADC-2/ Chart (flip side) for coordinates and elevations of aircraft stands.
6	<i>Remarks</i>	NIL

WSSS AD 2.9 SURFACE MOVEMENT GUIDANCE AND CONTROL SYSTEM AND MARKINGS

1	Use of aircraft stand ID signs, TWY guidelines and visual docking/parking guidance system of aircraft stands.
	Taxiing guidance signs at all intersections with TWY and RWY at all holding positions. Apron markings at aircraft stands. Nose-in guidance at aircraft stands. For information on Safegate Aircraft Docking Guidance System, Taxiing Guidance System at Singapore Changi Airport, refer to WSSS AD 2.9 .
2	RWY and TWY markings and LGT.
	<p><u>RWY 02L</u></p> <p>RWY LGT: refer to WSSS AD 2.14 and WSSS AD 2.15.</p> <p>TWY LGT: BLUE lights on TWY curved edges. BLUE TWY edge markers along selected straight TWY edge sections. Red stop bar at TWY INT controllable on/off. Red stop bar lights at Pattern "A" RWY HLDG PSN entrances to RWY are controllable on/off and are supplemented with elevated RWY guard lights and RWY designation sign at the sides. Red stop bar lights at Pattern "B" RWY HLDG PSN before entry into the RWY ILS sensitive area on the west of RWY 02L/20R are controllable on/off with Category I RWY HLDG PSN sign.</p> <p>Internally lighted mandatory or information TWY signboards.</p> <p>"MIL" destination signs on the west of RWY 02L/20R indicate the direction to aircraft movement area for military use only.</p> <p>Alternate green and yellow taxiway centreline lights along taxiways within ILS sensitive zone in the vicinity of the runway and green taxiway centreline lights with selective controls along taxi-routes to/from main RWY and aprons. On the west of RWY 02L/20R, no taxiway centreline lights.</p> <p>MARKING AIDS: THR, touchdown zone, RWY centreline, RWY side stripe, RWY designations, aiming point markings, TWY centreline, taxi holding positions – all taxiways, apron markings.</p>
	<p><u>RWY 20R</u></p> <p>RWY LGT: refer to WSSS AD 2.14 and WSSS AD 2.15.</p> <p>TWY LGT: same as for RWY 02L and RWY 02C/20C.</p> <p>MARKING AIDS: Pre-threshold centreline, transverse stripe for displaced THR, THR, touchdown zone, RWY centreline, RWY side stripe, RWY designations, aiming point markings, TWY centreline, taxi holding positions – all taxiways, apron markings.</p>

	<p><u>RWY 02C/20C</u></p> <p>RWY LGT: refer to <u>WSSS AD 2.14</u> and <u>WSSS AD 2.15</u>.</p> <p>TWY LGT: BLUE lights on TWY curved edges. BLUE TWY edge markers along selected straight TWY edge sections. Red stop bar lights at TWY INT are controllable on/off. Red stop bar lights at Pattern "A" RWY HLDG PSN entrances to RWY are controllable on/off and are supplemented with elevated RWY guard lights and RWY designation sign at the sides. Red stop bar lights at Pattern "B" RWY HLDG PSN before entry into the RWY ILS sensitive area are controllable on/off with Category I/II RWY HLDG PSN sign.</p> <p>Internally lighted mandatory or information TWY signboards.</p> <p>On the east and west of RWY 02C/20C, alternate green and yellow taxiway centreline lights along taxiways within ILS sensitive zone in the vicinity of the runway and green taxiway centreline lights with selective controls along taxi-routes to/from main RWY and aprons.</p> <p>On the east of RWY 02C/20C between Pattern "A" RWY HLDG PSN and Pattern "B" RWY HLDG PSN TWY, alternate green and yellow taxiway centreline lights along taxiways within ILS sensitive zone.</p> <p>Rapid Exit Taxiway Indicator LGT comprises a set of yellow unidirectional LGT positioned in a 3-2-1 sequence at 100m intervals prior to the point of tangency of the rapid exit taxiway centreline.</p> <p>MARKING AIDS: THR, touchdown zone, RWY centreline, RWY side stripe, RWY designations, aiming point markings, TWY centreline, taxi holding positions – all taxiways, apron markings.</p>
	<p><u>RWY 02R/20L</u></p> <p>RWY LGT: refer to WSSS AD 2.14 and WSSS AD 2.15.</p> <p>TWY LGT: Blue lights on TWY curved edges. Blue TWY edge markers along selected straight TWY edge sections. Red stop bar lights at TWY INT are controllable on/off. Red stop bar lights at Pattern "A" RWY HLDG PSN entrances to RWY are controllable on/off and are supplemented with elevated RWY guard lights and RWY designation sign at the sides. Red stop bar lights at Pattern "B" RWY HLDG PSN before entry into the RWY ILS sensitive area are controllable on/off with Category I/II RWY HLDG PSN sign.</p> <p>Internally lighted mandatory or information TWY signboards.</p> <p>"MIL" destination signs on the east of RWY 02R/20L indicate the direction to aircraft movement area for military use only.</p> <p>On the west of RWY 02R/20L, alternate green and yellow taxiway centreline lights along taxiways within ILS sensitive zone in the vicinity of the runway and green taxiway centreline lights with selective controls along taxi-routes to/from main RWY and aprons. On the east of RWY 02R/20L, no taxiway centreline lights.</p> <p>MARKING AIDS: THR, touchdown zone, RWY centreline, RWY side stripe, RWY designations, aiming point markings, TWY centreline, taxi holding positions – all taxiways, apron markings.</p>
3	<p><i>Stop bars:</i> Stop bars where appropriate.</p>
4	<p><i>Remarks:</i> Where Red stop bar is not present at the TWY INT, Yellow INTERMEDIATE HLDG PSN LGT will be used at TWY INT and switched on between sunset and sunrise or during periods of poor visibility.</p>

1 ADB SAFEGATE AIRCRAFT DOCKING GUIDANCE SYSTEM - SAFEDOCK

1.1 INTRODUCTION

1.1.1 The ADB Safegate Aircraft Docking Guidance System (ADGS) - SAFEDOCK is a fully automatic aircraft docking guidance system installed at the contact aircraft stands at Terminals 1, 2, 3 and 4, and at the remote aircraft stands at South Apron of Singapore Changi Airport.

1.2 DESCRIPTION OF SYSTEM

1.2.1 The system is based on a laser scanning technique and it tracks both the lateral and longitudinal position of the aircraft. This 3D technique allows the system to identify the incoming aircraft and check it against the one selected by the operator to ensure that the pilot is provided with the correct stop indication for the aircraft.

1.2.2 The system is operated only in the Automatic Mode. When the system fails, the aircraft is to be marshalled into the stand manually.







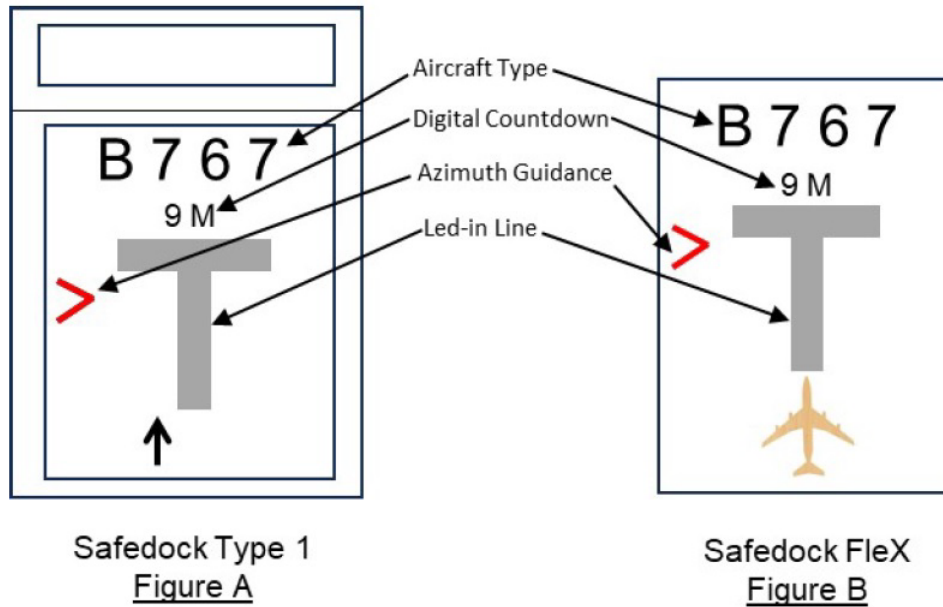

1.2.3 Azimuth guidance, continuous closing rate information, aircraft type, etc., are shown to the pilot on a single display clearly visible for both pilot and co-pilots. Figure A shows the Display and Laser Scanning Unit mounted on the terminal in front of the aircraft stand.







LED DISPLAY AND LASER SCANNING UNIT





LED DISPLAY AND LASER SCANNING UNIT

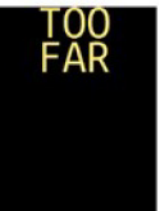
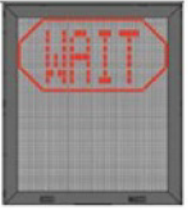



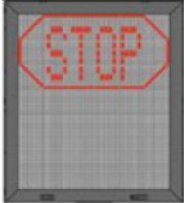



1.3 DOCKING PROCEDURES



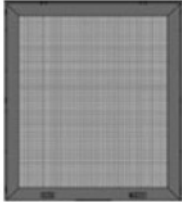

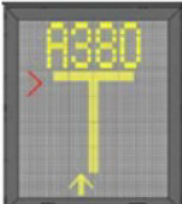





Description	Display on ADGS	
<p>Checking of Aircraft Type</p> <ul style="list-style-type: none"> Check that the correct aircraft type is displayed. The scrolling arrows indicate that the system is activated. Follow the lead-in line. 	<p>Safedock Type 1</p> 	<p>Safedock FleX</p> 
<p>Capture of Correct Aircraft Type</p> <ul style="list-style-type: none"> When the aircraft has been caught by the scanning unit, the scanning unit checks that the aircraft is the correct type and the display provides azimuth guidance information. When the solid yellow closing rate bar appears, the aircraft is being tracked by the system. 	<p>Safedock Type 1</p> 	<p>Safedock FleX</p> 
<p>Steering and Alignment of Aircraft</p> <ul style="list-style-type: none"> Look for the flashing red arrow and solid yellow arrow which provide azimuth guidance information. The flashing red arrow shows which direction to steer, while the solid yellow arrow gives an indication of how far the aircraft is off the centreline. 	<p>Safedock Type 1</p> 	<p>Safedock FleX</p> 
<p>Distance of Aircraft from STOP Position</p> <ul style="list-style-type: none"> When the aircraft is 15m from the stop position, closing rate information is given. "Distance to go" is indicated by turning off one row of LEDs (Laser Electronic Displays) for every half metre that the aircraft advances towards the stop position. From 15m to the stop position, the display will indicate the distance from the stop position for every 1m. At 3m from the stop position, the display will indicate the distance from the stop position for every 0.2m. 	<p>Safedock Type 1</p> 	<p>Safedock FleX</p> 

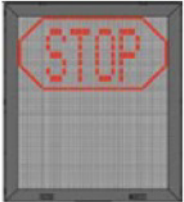



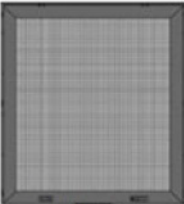

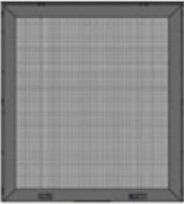
Description	Display on ADGS	
<p>STOP Position</p> <ul style="list-style-type: none"> When the correct stop position is reached, all of the LEDs for the closing rate bar will be off, the word "STOP" in red with red border will appear in the display. 	<p>Safedock Type 1</p> 	<p>Safedock Flex</p> 
<p>Checking of STOP Position</p> <ul style="list-style-type: none"> If the aircraft stops at the correct position, "OK" will be displayed after a few seconds. 	<p>Safedock Type 1</p> 	<p>Safedock Flex</p> 
<p>Overshooting of STOP Position</p> <ul style="list-style-type: none"> If the aircraft has gone past the correct stop position, the display will show "TOO FAR" after the aircraft comes to a complete stop. 	<p>Safedock Type 1</p> 	<p>Safedock Flex</p> 
<p>Object Blocking the View</p> <ul style="list-style-type: none"> If some object is blocking the view towards the approaching aircraft or the detected aircraft is lost before 12m to the correct stop position, the system will show "WAIT". 	<p>Safedock Type 1</p> 	<p>Safedock Flex</p> 

Description	Display on ADGS	
<p>Identification of Aircraft</p> <p>– The aircraft must be identified at least 12m before the correct stop position. Otherwise, the display will show “WAIT”, “STOP” and “ID FAIL”.</p>	<p style="text-align: center;">Safedock Type 1</p> <div style="text-align: center;">    </div>	<p style="text-align: center;">Safedock Flex</p> <div style="text-align: center;">    </div>

1.4 SAFETY MEASURES

Description	Display on ADGS
<p>ADGS Blank / Wrong Aircraft Type</p> <ul style="list-style-type: none"> Pilot should not turn an aircraft into the aircraft stand if the docking system is not activated or on seeing a wrong aircraft type displayed on the system. 	<div style="display: flex; justify-content: space-around;"> <div style="text-align: center;"> <p>Safedock Type 1</p>  </div> <div style="text-align: center;"> <p>Safedock FleX</p>  </div> </div>
<p>Proceeding beyond Passenger Loading Bridges</p> <ul style="list-style-type: none"> Pilot should not proceed beyond the passenger loading bridges unless the scrolling arrows (see figure 1) have been superseded by the solid yellow closing rate bar (see figure 2). 	<div style="display: flex; justify-content: space-around;"> <div style="text-align: center;"> <p>Safedock Type 1</p>  <p>Figure 1</p>  <p>Figure 2</p> </div> <div style="text-align: center;"> <p>Safedock FleX</p>  <p>Figure 1</p>  <p>Figure 2</p> </div> </div>
<p>Minimum Speed</p> <ul style="list-style-type: none"> When using the docking system, pilots are to taxi into the aircraft stand at minimum speed. The system will display "SLOW" to inform the pilot if the aircraft's taxiing speed exceeded 1.2m/s. 	<div style="display: flex; justify-content: space-around;"> <div style="text-align: center;"> <p>Safedock Type 1</p>  </div> <div style="text-align: center;"> <p>Safedock FleX</p>  </div> </div>

Description	Display on ADGS
<p>Slow Down (In Abnormal Situations)</p> <ul style="list-style-type: none"> In bad weather conditions, the docking system may go into downgrade mode. The display will show the aircraft type and "SLOW" and the scrolling arrows are disabled (See Figure 1). When the system has detected the aircraft, the solid yellow closing rate bar appears. Docking process is allowed to continue but pilot should exercise caution. 	<div style="display: flex; justify-content: space-around;"> <div style="text-align: center;"> <p>Safedock Type 1</p>  <p>Figure 1</p> </div> <div style="text-align: center;"> <p>Safedock FleX</p>  <p>Figure 1</p> </div> </div>
<p>Overshooting</p> <ul style="list-style-type: none"> To avoid overshooting, pilots are advised to approach the stop position slowly and observe the closing rate information displayed. Pilots should stop the aircraft immediately when seeing the "STOP" or "WAIT" display or when given the stop sign by the aircraft marshaller or is unsure of the information displayed during the docking process. 	<div style="display: flex; justify-content: space-around;"> <div style="text-align: center;"> <p>Safedock Type 1</p>  </div> <div style="text-align: center;"> <p>Safedock FleX</p>  </div> </div> <div style="display: flex; justify-content: space-around; margin-top: 20px;"> <div style="text-align: center;"> <p>Safedock Type 1</p>  </div> <div style="text-align: center;"> <p>Safedock FleX</p>  </div> </div>
<p>No Display</p> <ul style="list-style-type: none"> Pilot should stop the aircraft immediately if the display goes black, for power failure (see figure 1) or system failure (see figure 2), during the docking process. The aircraft is to be manually marshalled into the aircraft stand. 	<div style="display: flex; justify-content: space-around;"> <div style="text-align: center;"> <p>Safedock Type 1</p>  <p>Figure 1</p> </div> <div style="text-align: center;"> <p>Safedock FleX</p>  <p>Figure 1</p> </div> </div> <div style="display: flex; justify-content: space-around; margin-top: 20px;"> <div style="text-align: center;"> <p>Safedock Type 1</p>  <p>Figure 2</p> </div> <div style="text-align: center;"> <p>Safedock FleX</p>  <p>Figure 2</p> </div> </div>

Description	Display on ADGS
<p>Safety Backup (SBU) Stop</p> <p>- When a non-recoverable error has occurred during the docking due to either</p> <ol style="list-style-type: none"> 1. Hardware failure; 2. Aircraft more than +/- 0.5 meters off the centerline when two (2) meters or less to stop-position; or 3. System Failure <p>- Pilot are to stop the aircraft immediately when seeing the "SBU STOP" display or when given the stop sign by the aircraft marshaller or is unsure of the information displayed during the docking process.</p>	<div style="display: flex; justify-content: space-around; align-items: center;"> <div style="text-align: center;"> <p>Safedock Type 1</p>  </div> <div style="text-align: center;"> <p>Safedock Flex</p>  </div> </div>
<p>View Blocked</p> <p>- When the view towards the aircraft is hindered, the display will show "WAIT VIEW BLOCK" Pilot are to stop the aircraft immediately or when given the stop sign by the aircraft marshaller or is unsure of the information displayed during the docking process.</p>	<div style="display: flex; justify-content: space-around; align-items: center;"> <div style="text-align: center;"> <p>Safedock Type 1</p>  </div> <div style="text-align: center;"> <p>Safedock Flex</p>  </div> </div>
<p>Gate Block</p> <p>- When an object is found to be blocking the view from the ADGS toward the aircraft, the display will show "WAIT GATE BLOCK". Pilot are to stop the aircraft immediately or when the stop sign by the aircraft marshaller or is unsure of the information displayed during the docking process.</p>	<div style="display: flex; justify-content: space-around; align-items: center;"> <div style="text-align: center;"> <p>Safedock Type 1</p>  </div> <div style="text-align: center;"> <p>Safedock Flex</p>  </div> </div>

2 PROCEDURES FOR START-UP AND PUSHBACK OF AIRCRAFT

2.1 Ground crew shall ensure that the area behind an aircraft is clear of vehicles, equipment and other obstructions before the start-up or pushback of aircraft commences.

2.2 When it becomes necessary to vary a procedure to expedite aircraft movements, Ground Movement Controller ("Singapore Ground") shall issue specific instructions to the pilot.

2.3 When the pilot is ready for start-up and pushback, he shall seek confirmation from the ground crew that there is no hazard to his aircraft starting up. He shall then notify Singapore Ground that he is ready for pushback. On being told by Singapore Ground that pushback is approved, he shall co-ordinate with the ground crew for the start-up and pushback of the aircraft.

2.4 The lead-in lines are for aircraft nose-in guidance. For aircraft stands without dedicated pushback lines, ground crew may use the lead-in lines for pushback guidance.

2.5 For more information, refer to Airport Operations Centre System (AOCS) at <https://aoc.changiairport.com/> for detailed pushback procedures.

3 ADVANCED MULTILATERATION SYSTEM

3.1 INTRODUCTION

3.1.1 The Multilateration System is a new surveillance system which is able to detect and identify all Mode S equipped aircraft and vehicles moving on the airport surface even during bad weather conditions such as heavy rain. It will integrate with the current radar-based ground surveillance system as part of the Advanced-Surface Movement Guidance and Control System (A-SMGCS) at Singapore Changi Airport. This will enhance the efficiency and safety at the airport.

3.2 CARRIAGE OF MODE-S SSR TRANSPONDER

3.2.1 Carriage and operation of Mode-S transponder is required for all civil aircraft operating at Singapore Changi Airport. The Mode-S transponder shall comply, at least, to the requirements of Level 2 as prescribed in ICAO Annex 10 Volume IV (Amendment 77 or later) Standards and Recommended Practices.

3.3 MULTILATERATION SYSTEM OUTLINE

3.3.1 The Multilateration System uses multiple receivers to pick up “squitters” transmitted by aircraft or vehicle Mode S transponders. It calculates the position of an aircraft or a vehicle by comparing the time its “squitter” arrives at each receiver.

3.3.2 The System will derive the identity of an aircraft by selectively interrogating its transponder to receive its assigned Mode A code or extracting its aircraft identification [that is, the ICAO callsign used in flight and inserted in the Flight Management System (FMS) or the Transponder Control Panel], if available, from its squitter. For transponder equipped vehicles, the system will derive their respective identities from the unique Mode S addresses contained in their squitters.

3.4 AIRCRAFT REQUIREMENTS

3.4.1 The Multilateration System is essentially passive. It relies on aircraft transponders squittering at all times when moving on the airfield. At present, some aircraft checklist procedures instruct pilots to turn off the transponder shortly after leaving the runway on arrival and, not to switch it on until reaching the runway holding point for departure. This is in line with the requirement that Mode A/C transponders should not transmit on the ground, which does not apply to Mode S transmissions.

3.4.2 For the Multilateration System to work effectively, all aircraft Mode S transponders need to transmit Mode S squitters at all times when moving on the airfield, starting immediately prior to pushback, and for arrival aircraft until they are stationary at the aircraft stands. The Mode S transponders should not respond to All-Call interrogations, but should respond to addressed interrogations.

3.5 PROCEDURES/ACTIONS REQUIRED BY PILOTS

3.5.1 The Multilateration System needs to receive squitters and to acquire the Mode A code of a Mode S equipped aircraft at all times when it is on the ground. This is to enable detection and identification of the aircraft (from its Mode A code or ICAO callsign) as soon as it pushes back. Hence, the following actions from pilots are required.

3.5.2 Pre-Pushback / Taxi

- a) Pilots will be required to enter an assigned Mode A code at start-up. This code will be either a discrete or non-discrete code (a conspicuity code, e.g. 1000).
- b) Pilots shall ensure that the aircraft transponder is operating (that is, XPNDR or the equivalent according to specific installation, AUTO if available, not OFF or STBY) and the assigned Mode A code is selected prior to the request for pushback or taxi, whichever is earlier.
- c) Whenever the aircraft is capable of reporting aircraft identification, the aircraft identification must also be entered prior to the request for pushback or taxi, whichever is earlier, through the FMS or the Transponder Control Panel. Flight crew must use the 3-letter ICAO designator of the operator, followed by flight identification number (for example, BAW123, SIA002).

3.5.3 After Landing

- a) Pilots shall ensure that the aircraft transponder is operating (that is, XPNDR or the equivalent according to specific installation, AUTO if available, not OFF or STBY) after landing, and continuously until the aircraft is stationary at the aircraft stand.
- b) Pilots shall ensure that the assigned Mode A code is not changed until the aircraft is stationary at the aircraft stand. (The system requires it for identification of the aircraft).

4 AIRFIELD LIGHTING CONTROL SYSTEM (ALCS) AND MARKINGS

4.1 INTRODUCTION

4.1.1 The Advanced Surface Movement Guidance and Control System (A-SMGCS) at Singapore Changi Airport is able to control and monitor the runway and taxiway airfield lights such as the stop bars and green taxiway centreline lights, through the Airfield Lighting Control System. The system is designed to provide pilots with visual guidance while taking off, landing and taxiing during day/night operations and during periods of low visibility. It is controlled by air traffic controllers at Singapore Changi Airport using the A-SMGCS display.

4.2 TAXI INSTRUCTIONS

4.2.1 When the green centreline lights are switched on, ATC will issue verbal instructions to pilots/ airline operators for taxi / tow clearance. The green taxiway centreline lights are provided for guidance. Pilots/ airline operators shall stop at all red stop bar lights.

4.2.2 All green centreline lights on taxiways leading to the runways terminate at the runway holding positions where, by default, red stop bar lights remain on unless deselected by the Runway Controller. When deselected, these stop bar lights will re-activate automatically. Pilots and drivers shall not cross any lighted red stop bar lights.

4.2.3 Pilots and drivers shall enter / cross the runway or taxiway only when both the following conditions are met:
The crew have

- a) Received positive ATC clearance to enter / cross the runway or taxiway, and
- b) Observed that the red stop-bar lights are turned off.

4.3 INFORMATION AND MANDATORY SIGNS/MARKINGS

4.3.1 When following ATC verbal taxi instructions, pilots are advised to also navigate their taxi route with reference to information and mandatory signs/markings provided at the airport so as to maintain situational awareness of their whereabouts at all times.

WSSS AD 2.10 AERODROME OBSTACLES

1. Obstacles in Approach / TKOF areas

IN APPROACH / TKOF AREAS			
RWY/Area affected		Obstacles type, <i>ELEV,Markings/LGT</i>	Location of Obstacles
1		2	3
1)	RWY 20R APCH	Mast HGT ranging from 98ft AMSL and above.	Shipping channel APRX 2120m from DTHR RWY 20R.
	RWY 02L TKOF	Mast HGT ranging from 98ft AMSL and above.	Shipping channel APRX 1110m from DER RWY 02L.
2)	RWY 02L/20R APCH RWY 02L/20R TKOF	ILS LLZ co-located with LLZ antennae.	Within the RWY strip.
3)	RWY 20R APCH	Two antennae, HGT 72ft AMSL, marked and LGTD	012311N 1035928E
4)	RWY 20R APCH	Antenna, HGT 88ft AMSL, marked and LGTD	012315N 1035931E
5)	RWY 02L APCH	Antenna, HGT 82ft AMSL, marked and LGTD	012051N 1035827E
6)	RWY 02L APCH	Pole, HGT 128ft AMSL, marked and LGTD	011859N 1035748E
7)	RWY 02L APCH	Pole, HGT 160ft AMSL, marked and LGTD	012058N 1035814E
8)	RWY 02L APCH	Pole, HGT 131ft AMSL, marked and LGTD	012038N 1035848E
9)	RWY 20C APCH	Mast HGT ranging from 98ft AMSL and above.	Shipping channel APRX 2650m from THR RWY 20C.
	RWY 02C TKOF	Mast HGT ranging from 98ft AMSL and above.	Shipping channel APRX 2590m from DER RWY 02C.
10)	RWY 02C APCH RWY 20C TKOF	Trees HGT ranging up to 75ft AMSL	011909.0N 1035849.0E
11)	RWY 02C APCH RWY 20C TKOF	Approach lighting masts HGT ranging up to 35ft AMSL	Within APCH/TKOF
12)	RWY 02C APCH RWY 20C TKOF	ILS LLZ (South), 27ft AMSL, marked	011932.4N 1035901.3E

IN APPROACH / TKOF AREAS			
RWY/Area affected		Obstacles type, ELEV, Markings/LGT	Location of Obstacles
13)	RWY 02C APCH RWY 20C TKOF	LLZ Hut (South), 31ft AMSL, marked and LGTD	011934.1N 1035856.8E
14)	RWY 02C APCH RWY 20C TKOF	Mast, 62ft AMSL, marked and LGTD	011917.8N 1035901.5E
15)	RWY 20C APCH RWY 02C TKOF	Trees HGT ranging up to 92ft AMSL	012221.0N 1040022.2E
16)	RWY 20C APCH RWY 02C TKOF	Approach lighting masts HGT ranging up to 35ft AMSL	Within APCH/TKOF
17)	RWY 20C APCH RWY 02C TKOF	ILS LLZ (North), 27ft AMSL, marked	012154.8N 1040001.2E
18)	RWY 20C APCH RWY 02C TKOF	LLZ Hut (North), 31ft AMSL, marked and LGTD	012156.3N 1035957.6E
19)	RWY 20C APCH RWY 02C TKOF	Mast, 55ft AMSL, marked and LGTD	012200.4N 1040012.0E
20)	RWY 20L APCH	Mast HGT ranging from 98ft AMSL and above.	Shipping channel APRX 2190m from THR RWY 20L.
	RWY 02R TKOF	Mast HGT ranging from 98ft AMSL and above.	Shipping channel APRX 2130m from DER RWY 02R.
21)	RWY 02R APCH RWY 20L TKOF	ILS LLZ (South), 26ft AMSL	011909.5N 1035954.7E
22)	RWY 02R APCH RWY 20L TKOF	LLZ Building (South), 27ft AMSL	Within Approach
23)	RWY 02R APCH RWY 20L TKOF	MM Building (South), 27ft AMSL	Within Approach / Takeoff
24)	RWY 20L APCH RWY 02R TKOF	ILS LLZ (North), 26ft AMSL	012131.5N 1040054.7E
25)	RWY 20L APCH RWY 02R TKOF	LLZ Building (North), 28ft AMSL	Within Approach
26)	RWY 20L APCH RWY 02R TKOF	MM Building (North), 27ft AMSL	Within Approach / Takeoff

Remarks: Obstacles are shown on the AOC, IAC and VAC.

2. Obstacles in Circling area and at Aerodrome

IN CIRCLING AREA AND AT AERODROME		
Obstacles type, ELEV, Markings/LGT		Location of Obstacles
1		2
1)	RWY 02L/20R and RWY 02R/20L Wind direction indicators, marked and LGTD	Located at each end of RWY adjacent to GP Hut
2)	RWY 02C Wind direction indicator, 38ft AMSL, marked and LGTD	011954.7N 1035915.2E
3)	RWY 20C Wind direction indicator, 38ft AMSL, marked and LGTD	012124.9N 1035953.4E
4)	RWY 02L Anemometer, 48ft AMSL, marked and LGTD	012110.5N 1035840.2E
5)	RWY 20R Anemometer, 44ft AMSL, marked and LGTD	012222.7N 1035910.9E
6)	RWY 02C Anemometer, 49ft AMSL, marked and LGTD	011954.3N 1035914.9E
7)	RWY 20C Anemometer, 49ft AMSL, marked and LGTD	012043.4N 1035935.7E
8)	RWY 20C Anemometer, 49ft AMSL, marked and LGTD	012129.4N 1035955.1E
9)	RWY 02R Anemometer, 47ft AMSL, marked and LGTD	012105.7N 1040048.5E
10)	RWY 20L Anemometer, 48ft AMSL, marked and LGTD	011931.7N 1040008.8E
11)	RWY 02L GP Antenna, 67ft AMSL, marked and LGTD	012108.5N 1035839.1E
12)	RWY 20R GP Antenna, 67ft AMSL, marked and LGTD	012225.5N 1035912.2E
13)	RWY 02C GP Antenna, 67ft AMSL, marked and LGTD	011952.2N 1035913.7E

IN CIRCLING AREA AND AT AERODROME		
Obstacles type, ELEV, Markings/LGT		Location of Obstacles
14)	RWY 20C GP Antenna, 67ft AMSL, marked and LGTD	012131.7N 1035955.7E
15)	RWY 02R GP Antenna, 67ft AMSL, marked and LGTD	012108.9N 1040049.4E
16)	RWY 20L GP Antenna, 67ft AMSL, marked and LGTD	011929.1N 1040007.3E
17)	Antenna, HGT 82ft AMSL, marked and LGTD	012036N 1035819E
18)	Antenna, HGT 85ft AMSL, marked and LGTD	012039N 1035821E
19)	Antenna, HGT 78ft AMSL, marked and LGTD	012042N 1035823E
20)	Antenna, HGT 82ft AMSL, marked and LGTD	012053N 1035827E
21)	Antenna, HGT 78ft AMSL, marked and LGTD	012049N 1035826E
22)	FOD detection mast, HGT 46ft AMSL, marked and LGTD	011952.5N 1035913.9E
23)	FOD detection mast, HGT 37ft AMSL, marked and LGTD	011959.1N 1035917.2E
24)	FOD detection mast, HGT 37ft AMSL, marked and LGTD	012005.0N 1035919.6E
25)	FOD detection mast, HGT 37ft AMSL, marked and LGTD	012016.9N 1035924.7E
26)	FOD detection mast, HGT 37ft AMSL, marked and LGTD	012028.7N 1035929.7E
27)	FOD detection mast, HGT 37ft AMSL, marked and LGTD	012033.8N 1035931.8E
28)	FOD detection mast, HGT 38ft AMSL, marked and LGTD	012045.5N 1035936.8E
29)	FOD detection mast, HGT 37ft AMSL, marked and LGTD	012056.5N 1035941.5E
30)	FOD detection mast, HGT 37ft AMSL, marked and LGTD	012108.7N 1035946.6E
31)	FOD detection mast, HGT 37ft AMSL, marked and LGTD	012114.0N 1035948.8E
32)	FOD detection mast, HGT 37ft AMSL, marked and LGTD	012124.0N 1035953.1E
33)	FOD detection mast, HGT 38ft AMSL, marked and LGTD	012129.0N 1035954.9E
34)	FOD detection mast, HGT 45ft AMSL, marked and LGTD	011929.5N 1040007.5E
35)	FOD detection mast, HGT 45ft AMSL, marked and LGTD	011934.4N 1040009.8E
36)	FOD detection mast, HGT 45ft AMSL, marked and LGTD	011943.2N 1040013.6E
37)	FOD detection mast, HGT 45ft AMSL, marked and LGTD	011954.2N 1040018.2E
38)	FOD detection mast, HGT 45ft AMSL, marked and LGTD	012003.3N 1040022.0E
39)	FOD detection mast, HGT 45ft AMSL, marked and LGTD	012004.5N 1040022.5E
40)	FOD detection mast, HGT 45ft AMSL, marked and LGTD	012027.2N 1040031.8E
41)	FOD detection mast, HGT 45ft AMSL, marked and LGTD	012027.8N 1040032.0E
42)	FOD detection mast, HGT 45ft AMSL, marked and LGTD	012052.8N 1040042.9E
43)	FOD detection mast, HGT 45ft AMSL, marked and LGTD	012054.9N 1040043.8E
44)	FOD detection mast, HGT 45ft AMSL, marked and LGTD	012103.4N 1040047.4E
45)	FOD detection mast, HGT 45ft AMSL, marked and LGTD	012108.4N 1040049.3E
46)	Liquefied Natural Gas storage tanks, plants, gas stacks and flares within Malaysia's Pengerang Integrated Complex (PIC) extending up to HGT 1,500ft AMSL. Refer to AIP Malaysia for information on "Pengerang Integrated Complex Safety Area". Aircraft may overfly the area at 2,000ft and above.	Within area bounded by 012245N 1040705E 012245N 1040831E 012306N 1040954E 012301N 1041056E 012232N 1041058E 012114N 1041057E 012038N 1040939E 012031N 1040813E 012136N 1040704E 012245N 1040705E

Remarks: Obstacles are shown on the AOC, IAC and VAC.

WSSS AD 2.11 METEOROLOGICAL INFORMATION PROVIDED

1	Associated MET Office	Singapore Changi (WSSS)
2	Hours of service	H24

3	Office responsible for TAF preparation Periods of validity	Singapore Changi (WSSS) 12, 30
4	Type of landing forecast, Interval of issuance	TREND
5	Briefing/consultation provided	P
6	Flight documentation, Language used	Charts or Tabular forms, English
7	Charts and other information available for briefing or consultation	S, U, P
8	Supplementary equipment available for providing information	HRPT: High Resolution Picture Transmission APT: Automatic Picture Transmission MDWR: MET Doppler Weather Radar MAINT: Second WED of every month BTN 0200-0900 ALTN period: THU following the second WED.
9	ATS units provided with information	Singapore ACC, Singapore RCC
10	Additional information	Tel: 65422837 (MET Office)

WSSS AD 2.12 RUNWAY PHYSICAL CHARACTERISTICS

Designations RWY NR	TRUE BRG	Dimensions of RWY	Strength (PCR) and surface of RWY and SWY	THR coordinates and RWY end coordinates (THR Geoid Undulation)	THR Elevation and highest elevation of TDZ of precision APCHRWY
1	2	3	4	5	6
02L	023.02°	4000m X 60m	710/F/B/X/U Grooved Bituminous Concrete	THR coordinates: 012056.27N 1035838.82E RWY end coordinates: 012256.13N 1035929.42E (10.23m)	6.64m 6.64m
20R (Threshold displaced by 740m southwards)	203.02°	4000m X 60m	710/F/B/X/U Grooved Bituminous Concrete	THR coordinates: 012234.02N 1035920.09E RWY end coordinates: 012056.27N 1035838.82E (10.26m)	3.98m 4.67m
02C	023.01°	4000m X 60m	710/F/B/X/U Grooved Bituminous Concrete	THR coordinates: 011943.51N 1035905.86E RWY end coordinates: 012143.37N 1035956.46E (10.27m)	4.80m 4.80m
20C	203.01°	4000m X 60m	710/F/B/X/U Grooved Bituminous Concrete	THR coordinates: 012143.37N 1035956.46E RWY end coordinates: 011943.51N 1035905.86E (10.30m)	4.80m 4.80m
02R	023.01°	4000m X 60m	710/F/B/X/U Grooved Bituminous Concrete	THR coordinates: 011920.59N 1035959.45E RWY end coordinates: 012120.45N 1040050.05E (10.32m)	4.77m 4.77m

Designations RWY NR	TRUE BRG	Dimensions of RWY	Strength (PCR) and surface of RWY and SWY	THR coordinates and RWY end coordinates (THR Geoid Undulation)	THR Elevation and highest elevation of TDZ of precision APCHRWY
1	2	3	4	5	6
20L	203.01°	4000m X 60m	710/F/B/X/U Grooved Bituminous Concrete	THR coordinates: 012120.45N 1040050.05E RWY end coordinates: 011920.59N 1035959.45E (10.36m)	4.71m 4.75m

Slope of RWY-SWY Transverse/ Longitudinal	SWY Dimensions (m)	CWY Dimensions (m)	STRIP dimensions (m)	Dimensions of RESA (m)	Locations and description of ARST system	OFZ
7	8	9	10	11	12	13
RWY 02L 1.15% / 0.07% SWY 1.44% / 0.23%	60 X 60	270 X 150	4250 X 280	240 X 150	Not Applicable	Yes
RWY 20R 1.15% / 0.07% SWY 0.74% / 0.28%	60 X 60	270 X 150	4240 X 280	240 X 150	Not Applicable	Yes
RWY 02C 1.25% / 0.00% SWY 1.25% / 0.00%	60 X 60	60 X 150	4240 X 280	240 X 150	Not Applicable	Yes
RWY 20C 1.25% / 0.00% SWY 1.25% / 0.00%	60 X 60	60 X 150	4240 X 280	240 X 150	Not Applicable	Yes
RWY 02R 1.25% / 0% SWY 1.21% / 0%	60 X 60	60 X 150	4240 X 280	240 X 150	Not Applicable	Yes
RWY 20L 1.25% / 0% SWY 1.22% / 0%	60 X 60	60 X 150	4240 X 280	240 X 150	Not Applicable	Yes

Remarks

14

- 1) Open-air drains, demarcated by frangible poles, within the runway strip of RWY 02R/20L.
- 2) Not in use military hookwire system embedded in runway pavement at 490m from RWY 02R and RWY 20L thresholds.
- 3) Frangible End Around Taxiway (EAT) visual screens located at the approach/take-off end of RWY 02C and RWY 20C do not penetrate the obstacle limitation surfaces of RWY 02C/20C. The EAT visual screens are marked in diagonal red-white stripes and installed with additional red obstacle lights. The EAT visual screens are intended to help pilots operating on RWY 02C/20C to differentiate between an aircraft crossing the runway or taxiing on end-around taxiways TWY K and TWY L.
- 4) **Scheduled Closure of RWY 02L/20R**
 - a) BTN 1700-2100UTC on every SUN and WED of the month (preventive maintenance work).
In the event of emergency, RWY will be re-opened within 30 minutes.
 - b) A 5-minute inspection conducted within the periods BTN 0100-0359UTC 0500-0759UTC 0800-1059UTC daily.
- 5) **Scheduled Closure of RWY 02C/20C**
 - a) BTN 1700-2100UTC on every MON of the month (preventive maintenance work).
In the event of emergency, RWY will be re-opened within 30 minutes.
 - b) A 5-minute inspection conducted within the periods BTN 0100-0359UTC 0500-0759UTC 0800-1059UTC daily.
- 6) **Scheduled Closure of RWY 02R/20L**
 - a) BTN 1700-2100UTC on every TUES and FRI of the month (preventive maintenance work).
In the event of emergency, RWY will be re-opened within 30 minutes.
 - b) A 5-minute inspection conducted within the periods BTN 0100-0359UTC 0500-0759UTC 0800-1059UTC daily.
- 7) **Additional Inspection and Maintenance Closures**
 - a) On days when there is a scheduled 4-hour runway closure BTN 1700-2100UTC
 - i. 10-minute inspection conducted within the period BTN 1500-1610UTC on the other operational runway(s);
 - ii. 15-minute inspection conducted within the period BTN 2300-2359UTC on the other operational runway(s);
 - iii. 5-minute inspection conducted within period BTN 2300-2359UTC on the re-opened runway.
 - b) On days when there is no scheduled 4-hour runway closure BTN 1700-2100UTC
 - I. RWY 02L/20R:
 - i. 5-minute inspection conducted BTN 2300-2305UTC
 - ii. 30-minute maintenance will be conducted BTN 1830-1900UTC
 - II. RWY 02C/20C:
 - i. 5-minute inspection conducted BTN 2315-2320UTC
 - ii. 60-minute maintenance will be conducted BTN 2000-2100UTC
 - III. RWY 02R/20L:
 - i. 5-minute inspection conducted BTN 2330-2335UTC
 - ii. 60-minute maintenance will be conducted BTN 2100-2130UTC

WSSS AD 2.13 DECLARED DISTANCES

RWY Designator	Intersection Departures	TORA (m)	TODA (m)	ASDA (m)	LDA (m)	Remarks
1	2	3	4	5	6	7
20R	Not applicable	4000	4270	4060	3260	THR displaced by 740m southwards
	W2	3842	4112	3902	Not applicable	
	W3	3026	3296	3086	Not applicable	
02L	Not applicable	4000	4270	4060	4000	NIL
	W8	3842	4112	3902	Not applicable	
	W7	3026	3296	3086	Not applicable	

RWY Designator	Intersection Departures	TORA (m)	TODA (m)	ASDA (m)	LDA (m)	Remarks
1	2	3	4	5	6	7
20C	Not applicable	4000	4060	4060	4000	NIL
	T3	3808	3868	3868	Not applicable	
	T4	3421	3481	3481	Not applicable	
	T5	2721	2781	2781	Not applicable	
	D3	3842	3902	3902	Not applicable	
	D4	3502	3562	3562	Not applicable	
	D5	3027	3087	3087	Not applicable	
	D6	2552	2612	2612	Not applicable	
02C	Not applicable	4000	4060	4060	4000	NIL
	T11	3842	3902	3902	Not applicable	
	T10	3329	3389	3389	Not applicable	
	T9	3197	3257	3257	Not applicable	
	T8	2551	2611	2611	Not applicable	
	D12	3842	3902	3902	Not applicable	
	D11	3480	3540	3540	Not applicable	
	D10	2877	2937	2937	Not applicable	
20L	Not applicable	4000	4060	4060	4000	NIL
	A3	3842	3902	3902	Not applicable	
	A4	3027	3087	3087	Not applicable	
	A5	2552	2612	2612	Not applicable	
02R	Not applicable	4000	4060	4060	4000	NIL
	A10	3842	3902	3902	Not applicable	
	A9	2877	2937	2937	Not applicable	
	A8	2402	2462	2462	Not applicable	

Note: Intersection departures are allowed subject to the following:

- a) initiated by pilot and approved by ATC, traffic permitting.
- b) ATC is able to keep aircraft visual at all times

WSSS AD 2.14 APPROACH AND RUNWAY LIGHTING

RWY	APCH LGT Type, LEN, Intensity	THR LGT colour WBAR	PAPI (MEHT)	TDZ LGT LEN	RWY Centreline LGT, LEN, spacing, colour, INTST	RWY Edge LGT, LEN, spacing, colour, INTST	RWY End LGT colour	SWY LGT colour
1	2	3	4	5	6	7	8	9
02L	CAT II High Intensity approach lighting (900m) consisting of extended centreline and RED row barrettes, 2 crossbars, 2 approach beacons and sequenced flashing lights.	GREEN supplemented by Green wing-bar and 2 THR ident lights.	PAPI 003° located either side of RWY, 422m behind RWY THR. 2 WHITE LGT and 2 RED LGT (20.0m), 3 WHITE LGT and 1 RED LGT (24.0m), 4 WHITE LGT (26.4m). ACFT with eye-to-wheel height greater than 8m are advised to fly with 2 WHITE and 2 RED LGT visible so as to achieve sufficient wheel clearance.	WHITE	Inset High Intensity centreline lights (longitudinal spacing at 30m apart) as follows: From THR to 900m from RWY end: WHITE, 300m to 900m from RWY end: ALTN RED/ WHITE, 300m to RWY end: RED.	Bi-directional White/Amber edge lights (longitudinal spacing at 60m apart) as follows: From THR to 600m from RWY end: White, 600m to RWY end: Amber.	RED	RED
20R	CAT1 High Intensity approach lighting (900m) distance coded centreline lights showing variable WHITE and crossbars at 150m, 300m, 450m, 600m and 750m.	GREEN supplemented by Green wing-bar and 2 THR ident lights.	PAPI 003° located either side of RWY, 410m from THR. 2 WHITE LGT and 2 RED LGT (19.5m), 3 White LGT and 1 RED LGT (23.3m), 4 WHITE LGT (25.7m). ACFT with eye-to-wheel height greater than 8m are advised to fly with 2 WHITE and 2 RED LGT visible so as to achieve sufficient wheel clearance.	NIL	Inset High Intensity centreline lights (longitudinal spacing at 30m apart) as follows: From THR to 900m from RWY end: WHITE, 300m to 900m from RWY end: ALTN RED/ WHITE, 300m to RWY end: RED.	RED RWY edge lights (longitudinal spacing at 60m apart) in the direction of RWY 20R before the displaced THR. Bi- directional raised WHITE/ AMBER edge lights (longitudinal spacing at 60m apart) after the displaced THR.	RED	Elevated RED

RWY	APCH LGT Type, LEN, Intensity	THR LGT colour WBAR	PAPI (MEHT)	TDZ LGT LEN	RWY Centreline LGT, LEN, spacing, colour, INTST	RWY Edge LGT, LEN, spacing, colour, INTST	RWY End LGT colour	SWY LGT colour
1	2	3	4	5	6	7	8	9
02C	CAT II High Intensity approach lighting (900m) consisting of extended centreline and RED row barrettes , 2 crossbars, 2 approach beacons and sequenced flashing lights.	Green supplemented by green wing-bar and 2 THR ident lights.	PAPI 003° located either side of RWY, 418m from THR. 2 WHITE LGT and 2 RED LGT (19.8m), 3 WHITE LGT and 1 RED LGT (23.7m), 4 WHITE LGT (26.2m). ACFT with eye-to-wheel height greater than 8m are advised to fly with 2 WHITE and 2 RED LGT visible so as to achieve sufficient wheel clearance.	WHITE. 900m (From THR) TDZ. Every 60m from THR.	Inset High Intensity centreline lights as follows: From THR to 900m from RWY end: WHITE, 300m to 900m from RWY end: ALTN RED/ WHITE, 300m to RWY end: RED.	Bi-directional WHITE/ AMBER edge lights as follows: From THR to 600m from RWY end: White, 600m to RWY end: Amber.	RED	RED
20C	CAT II High Intensity approach lighting (900m) consisting of extended centreline and RED row barrettes, 2 crossbars, 2 approach beacons and sequenced flashing lights.	Green supplemented by green wing-bar and 2 THR ident lights.	PAPI 003° located on left side of RWY, 418m from THR. 2 WHITE LGT and 2 RED LGT (19.8m), 3 WHITE LGT and 1 RED LGT (23.7m), 4 WHITE LGT (26.2m). ACFT with eye-to-wheel height greater than 8m are advised to fly with 2 WHITE and 2 RED LGT visible so as to achieve sufficient wheel clearance.	WHITE 900m (From THR) TDZ. Every 60m from THR.	Inset High Intensity centreline lights as follows: From THR to 900m from RWY end: WHITE, 300m to 900m from RWY end: ALTN RED/WHITE, 300m to RWY end: RED.	Bi-directional WHITE/ AMBER edge lights as follows: From THR to 600m from RWY end: White, 600m to RWY end: Amber.	RED	RED

RWY	APCH LGT Type, LEN, Intensity	THR LGT colour WBAR	PAPI (MEHT)	TDZ LGT LEN	RWY Centreline LGT, LEN, spacing, colour, INTST	RWY Edge LGT, LEN, spacing, colour, INTST	RWY End LGT colour	SWY LGT colour
1	2	3	4	5	6	7	8	9
02R	CAT II High Intensity Approach Lights (900m) consisting of extended centreline and Red row barrettes, 2 crossbars, 2 approach beacons and sequenced flashing lights.	Green supplemented by green wing-bar and 2 THR ident lights.	PAPI 003° located either side of RWY, 415m from THR. 2 White lights and 2 Red lights (19.7m), 3 White lights and 1 Red light (23.6m), 4 White lights (26.0m). ACFT with eye-to- wheel height greater than 8m are advised to fly with 2 White and 2 Red lights visible so as to achieve sufficient wheel clearance.	White. 900m (From THR) TDZ. Every 60m from THR.	Inset High Intensity centreline lights (longitudinal spacing at 30m apart) as follows: From THR to 900m from RWY end: White, 300m to 900m from RWY end: ALTN Red/ White, 300m to RWY end: Red.	Bi-directional White/Amber edge lights (longitudinal spacing at 60m apart) as follows: From THR to 600m from RWY end: White, 600m to RWY end: Amber.	Red	Red
20L	CAT II High Intensity Approach Lights (900m) consisting of extended centreline and Red row barrettes, 2 crossbars, 2 approach beacons and sequenced flashing lights.	Green supplemented by green wing-bar and 2 THR ident lights.	PAPI 003° located either side of RWY, 415m from THR. 2 White lights and 2 Red lights (19.7m), 3 White lights and 1 Red light (23.6m), 4 White lights (26.0m). ACFT with eye-to- wheel height greater than 8m are advised to fly with 2 White and 2 Red lights visible so as to achieve sufficient wheel clearance.	White. 900m (From THR) TDZ. Every 60m from THR.	Inset High Intensity centreline lights (longitudinal spacing at 30m apart) as follows: From THR to 900m from RWY end: White, 300m to 900m from RWY end: ALTN Red/ White, 300m to RWY end: Red.	Bi-directional White/Amber edge lights (longitudinal spacing at 60m apart) as follows: From THR to 600m from RWY end: White, 600m to RWY end: Amber.	Red	Red

WSSS AD 2.15 OTHER LIGHTING, SECONDARY POWER SUPPLY

1	ABN/IBN location, characteristics and hours of operation	ABN: 012209.20N 1035858.43E (western side of RWY 02L/20R) ALTN FLG W G EV 2.3 SEC, Operating hours HN + IMC IBN: 012301.27N 1035959.49E (top of Cargo Agents Building E) FLG G 'SS' EV 7 SEC, Operating hours HN + IMC
---	--	--

2	<i>Anemometer location and LGT</i>	<p>RWY 02L/20R: Pressure tube anemometer and wind vane situated 345m west of middle of the runway. Cup anemometers and wind vanes at ends and middle of the runway. Windssocks at ends of the runway. Transmissometers at both ends and in the middle of the runway.</p> <p>RWY 02C/20C: Three ultrasonic wind sensors at the ends and middle of the runway. Windssocks at the ends of the runway. Transmissometers at both ends and in the middle of the runway.</p> <p>RWY 02R/20L: Three ultrasonic wind sensors at the ends and middle of the runway. Windssocks at the ends of the runway. Transmissometers at both ends and in the middle of the runway.</p>
3	<i>TWY Edge and Centreline Lighting</i>	<p>RWY 02L/20R and RWY 02C/20C: BLUE lights on TWY curved edges and apron TWY edges and GREEN centreline lights on all TWY.</p> <p>RWY 02R/20L: Blue lights on TWY curved edges and Green centreline lights on all TWY.</p>
4	<i>Secondary power supply/switch-over time</i>	Automatic standby generator power supply AVBL for airfield lighting with switchover time of 1 second during Category II low visibility operations.
5	<i>Remarks</i>	Vehicles painted yellow or displaying chequered red/white or orange/white flag at highest point of vehicle

WSSS AD 2.16 HELICOPTER LANDING AREA

Refer to [ENR 3.4](#)

WSSS AD 2.17 ATS AIRSPACE

1	<i>Designation and Lateral Limits</i>	CHANGI CTR 013300N 1040149E 013042N 1040654E 012542N 1040448E thence along Kuala Lumpur/ Singapore FIR BDRY to 012000N 1041218E 010018N 1035524E 011100N 1035134E 013300N 1040149E
2	<i>Vertical Limits</i>	SFC to 3,000ft ALT
3	<i>Airspace Classification</i>	C
4	<i>ATS Unit Callsign Language(s)</i>	Singapore Tower English
5	<i>Transition Altitude</i>	11000 FT (3,350m)
6	<i>Remarks</i>	A helicopter shall not be operated within the Changi CTR unless prior permission has been obtained from the Director-General of Civil Aviation, CAAS. Email to caas_ats_ansp@caas.gov.sg

WSSS AD 2.18 ATS COMMUNICATION FACILITIES

Service Designation	Call sign	Frequency (P-Pri, S-Sec)	Hours of operation	Remarks
APP	Singapore Departure	P120.3 MHz S133.0 MHz S132.15 MHz	H24	DEP from all airports in Singapore.
	Singapore Arrival	P119.3 MHz S119.4 MHz S119.55 MHz		TAR - Intermediate and final approach to Singapore Changi AP.
	Singapore Approach	P124.05 MHz S124.6 MHz S126.3 MHz	2100-1700	TAR - flow control service provided for ARR/DEP ACFT. Intermediate approach to Singapore Changi AP and other airports in Singapore.

Service Designation	Call sign	Frequency (P-Pri, S-Sec)	Hours of operation	Remarks
TWR	Singapore Tower	118.6 MHz	H24	for TKOF/LDG. for ACFT operating on RWY 02L/20R for vehicular movements on RWY 02L/20R
		118.25 MHz		for ACFT operating on RWY 02C/20C for vehicular movements on RWY 02C/20C for ground movement of ACFT (including ACFT on tow) north and south of RWY 02C/20C
		131.4 MHz		for ACFT operating on RWY 02R/20L for vehicular movements on RWY 02R/20L
	Singapore Ground	124.3 MHz	0000-1800 2100- 0000	for push-back / taxiing of all ACFT, including ACFT on tow, west of Terminal 3
		121.725 MHz	0000-1700 2100-0000	for push-back / taxiing of all ACFT (including ACFT on tow) east of Terminal 2 and west of TWY B (excluding TWY J8, J9, J10 and J12)
		121.85 MHz	0000-1600	for push-back / taxiing of all ACFT including ACFT on tow, north of Terminal 1
			1600- 0000	for push-back/ taxiing of all ACFT
		121.00 MHz	H24	for ground emergency
		122.55 MHz		for push-back / taxiing of all ACFT (including ACFT on tow) east of Terminal 4
		125.65 MHz		for push-back / taxiing of all ACFT (including ACFT on tow) west of Terminal 4
		127.275 MHz		for taxiing of all ACFT (including ACFT on tow) west of RWY 02R/20L
	Singapore Delivery	121.65 MHz	H24	for Pre-flight check/ATC clearance
		119.6 MHz	0030-0230 1200-1300	for issuance of ATC clearance

Service Designation	Call sign	Frequency (P-Pri, S-Sec)	Hours of operation	Remarks
TWR	Changi Tower / Changi Apron	121.9MHz	H24	Requests for engine runs on aprons and taxiways, excluding runways, would be regulated by Changi Apron. All towing request to contact Changi Apron followed by instruction to contact respective Singapore Ground frequency for towing clearance. Request for vehicular movements on taxiways, excluding runways, would be regulated by Changi Tower. For ACFT on tow and vehicular movements on the runway when the runway is closed for maintenance. All personnel operating the radio station on board an ACFT that is on the ground in Changi Airport should possess the Aircraft Radio Operator Approval (AROA) or other equivalent certification.
	Changi East Tower	119.675MHz	H24	Request for vehicular movements on taxiways, excluding runway, west of RWY 02R/20L and east of TWY C will be regulated by Changi East Tower. For ACFT on tow and vehicular movements on RWY 02R/20L when the runway is closed for maintenance. All personnel operating the radio station on board an ACFT that is on the ground in Changi Airport should possess the Aircraft Radio Operator Approval (AROA) or other equivalent certification.
	Changi East Ground	120.95MHz	Not for use, unless with prior coordination	For start-up / taxiing of all aircraft
D-ATIS	Changi Airport Departure Information	128.6MHz	H24	(broadcasting with half hourly updated MET INFO)
	Changi Airport Arrival Information	128.025MHz	H24	Data Link Service available. AP IDENT WSSS Messages comply with ARINC 623 Standards. Updating of data: H+00 to H+10 and H+30 to H+40
ATIS	Changi East Information (02R/ 20L)	139.95MHz	Not for use, unless with prior coordination	NIL

WSSS AD 2.19 RADIO NAVIGATION AND LANDING AIDS

Type of aid and Variation	IDENT	Frequency	OPR Hour	Position of Transmitting Antenna Coordinates	DME Transmitting Antenna Elevation / Remarks
1	2	3	4	5	6 & 7
SINJON DVOR/DME	SJ	113.5MHz CH82X	H24	011321.34N 1035115.22E	201° MAG 14.5km from THR RWY 02 (Paya Lebar). Antenna HGT: 190ft AMSL. Coverage 200NM. EM: F1. Maintenance period: Third Thursday of every month between 0200-0600

Type of aid and Variation	IDENT	Frequency	OPR Hour	Position of Transmitting Antenna Coordinates	DME Transmitting Antenna Elevation / Remarks
1	2	3	4	5	6 & 7
TEKONG DVOR/DME	VTK	116.5MHz CH112X	H24	012455.36N 1040120.17E	023° MAG 6.4km from THR RWY 20C (Singapore Changi). Antenna HGT: 150ft AMSL. Coverage 200NM. EM: F1 Maintenance Period: Third Friday of every month between 0200-0600
RWY 20C ILS LLZ	ICC	109.7MHz	H24	011932.40N 1035901.32E	Located 368m (1207ft) from THR RWY 02C, along RWY centreline. Course width 2.80°. EM: A0/A2.
RWY 20C ILS GP	-	333.2MHz	H24	012131.73 1035955.71E	Located 338m (1109ft) from THR RWY 20C on left side of RWY, 120m (394ft) from RWY centreline. GP angle 3°. HGT of ILS Reference Datum: 16.2m (53ft). EM: A0/A2.
RWY 20C ILS_DME	ICC	CH34X	H24	012131.73N 1035955.71E	DME co-located with GP. EM: P9.
RWY 20C ILS MM	-	75MHz	H24	012212.24N 1040008.87E	Located 964m (3162ft) from THR RWY 20C along extended centreline of RWY. No back beam.
RWY 02C ILS LLZ	ICE	108.3MHz	H24	012154.47N 1040001.18E	Located 368m (1207ft) from THR RWY 20C, along RWY centreline. Course width 2.80°. EM: A0/A2.
RWY 02C ILS GP	-	334.1MHz	H24	011952.18N 1035913.68E	Located 338m (1109ft) from THR RWY 02C on right side of RWY, 120m (394ft) from RWY centreline. GP angle 3°. HGT of ILS Reference Datum: 16.5m (54ft). EM: A0/A2.
RWY 02C ILS_DME	ICE	CH20X	H24	011952.18N 1035913.68E	DME co-located with GP. EM: P9.
RWY 02C ILS MM	-	75MHz	H24	011914.72N 1035853.19E	Located 966m (3169ft) from THR RWY 02C along extended centreline of RWY. No back beam.
RWY 20R ILS LLZ	ICH	108.9MHz	H24	012045.23N 1035834.17E	Located 368m (1207ft) from THR RWY 02L, along centreline of the RWY. Course width 3.38°. EM: A0/A2.
RWY 20R ILS GP	-	329.3MHz	H24	012225.59N 1035912.29E	Located 330m (1083ft) from displaced THR RWY 20R on right side of the RWY, 120m (394ft) from RWY centreline. GP angle 3°. HGT of ILS Reference Datum: 17m (56ft). EM: A0/A2.
RWY 20R ILS_DME	ICH	CH26X	H24	012225.59N 1035912.29E	DME co-located with GP. RWY 20R ILS DME not available beyond 15 degrees west of RWY 20R centreline below 2500ft. EM: P9.
RWY 20R ILS MM	-	75MHz	H24	012307.51N 1035934.24E	Located 1122m (3681ft) from displaced THR RWY 20R, along centreline of the RWY.
RWY 02L ILS LLZ	ICW	110.9MHz	H24	012307.03N 1035934.03E	Located 1105m (3625ft) from displaced THR RWY 20R, along centreline of RWY. Course width 2.81°. EM:A0/A2.

Type of aid and Variation	IDENT	Frequency	OPR Hour	Position of Transmitting Antenna Coordinates	DME Transmitting Antenna Elevation / Remarks
1	2	3	4	5	6 & 7
RWY 02L ILS GP	-	330.8 MHz	H24	012108.35N 1035838.86E	Located 343m (1125ft) from THR RWY 02L on left side of RWY, 143m (469ft) from RWY centreline. GP angle 3°. HGT of ILS Reference Datum: 17m (56ft). EM:A0/A2.
RWY 02L ILS_DME	ICW	CH46X	H24	012108.35N 1035838.86E	DME co-located with GP. EM:P9.
RWY 02L ILS MM	-	75MHz	H24	012027.54N 1035826.68E	Located 957m (3140ft) from THR RWY 02L along extended centreline of RWY. No back beam.
RWY 20L ILS LLZ	ICZ	108.55MHz	H24	011909.54N 1035954.79E	Located 367m (1204ft) from THR RWY 02R, along RWY centreline. Course width 2.80°. EM: A0/A2.
RWY 20L ILS GP	-	329.75MHz	H24	012108.89N 1040049.38E	Located 335m (1099ft) from THR RWY 20L on left side of the RWY, 120m (394ft) from RWY centreline. GP angle 3°. HGT of ILS REF datum: 16.8m (55ft). EM: A0/A2.
RWY 20L ILS DME	ICZ	CH22Y	H24	012108.89N 1040049.38E	DME co-located with GP. EM: P9.
RWY 20L ILS MM	-	75MHz	H24	012149.37N 1040102.55E	Located 968m (3176ft) from THR RWY 20L, along extended centreline of the RWY.
RWY 02R ILS LLZ	ICX	110.5MHz	H24	012131.46N 1040054.70E	Located 367m (1204ft) from THR RWY 20L, along RWY centreline. Course width 2.80°. EM: A0/A2.
RWY 02R ILS GP	-	329.6MHz	H24	011929.11N 1040007.26E	Located 335m (1099ft) from THR RWY 02R on right side of the RWY, 120m (394ft) from RWY centreline. GP angle 3°. HGT of ILS REF datum: 16.2m (53ft). EM: A0/A2.
RWY 02R ILS DME	ICX	CH42X	H24	011929.11N 1040007.26E	DME co-located with GP EM: P9
RWY 02R ILS MM	-	75MHz	H24	011851.60N 1035947.22E	Located 974m (3196ft) from THR RWY 02R, along extended centreline of the RWY.

WSSS AD 2.20 LOCAL AERODROME REGULATIONS

1 DESIGNATION OF PAYA LEBAR AIRPORT AS AN ALTERNATE AERODROME FOR SINGAPORE CHANGI AIRPORT

Please refer to section WSAP AD 2.20 for details.

2 WRONG APPROACHES AND LANDINGS OF AIRCRAFT BOUND FOR SINGAPORE CHANGI AND PAYA LEBAR AIRPORTS

2.1 INTRODUCTION

2.1.1 The attention of all pilots is drawn to the existence of Paya Lebar Airport close to Singapore Changi Airport. The runway at Singapore Changi Airport is orientated in the same true bearing as the runway at Paya Lebar Airport i.e. 023°/203°. Due to the close proximity of these two runways, pilots are cautioned against mistaking Paya Lebar Airport for the runway of Singapore Changi Airport and thus making an inadvertent visual landing or approach to land at Paya Lebar.

2.1.2 Erroneous approaches or landings usually occurred during the hours of darkness. In almost every instance, the weather prevailing at the time of the incident was generally good or fair.

2.1.3 There is intensive local flying at Paya Lebar and Seletar during the day and night. Thus, the risk of collision is very great if a wrong approach is made to any of the above two airports. Likewise, wrong approaches into Singapore Changi Airport can also be disastrous.

2.2 POINTS TO BEAR IN MIND WHEN APPROACHING SINGAPORE CHANGI AIRPORT OR PAYA LEBAR

2.2.1 The following points are highlighted to serve as a guide to assist pilots in making a correct approach into Singapore Changi Airport or Paya Lebar Airport and should be remembered and followed:

- a) The runways at Singapore Changi Airport and Paya Lebar Airport are identically aligned on 02/ 20. Therefore exercise extreme vigilance when leaving NYLON or SAMKO Holding Areas inbound and maintain correct tracks to the respective runways as listed below.
- b) Adhere strictly to IFR procedures even in VMC which calls for a procedure turn over NYLON Holding Area or SAMKO Holding Area as prescribed.
- c) Make full use of all available navigational and landing aids available and positively identify every aid used.
- d) Switch to the correct ILS localizer frequency at Singapore Changi Airport under all conditions.

2.3 AERODROME CHARACTERISTICS OF SINGAPORE CHANGI AND PAYA LEBAR AIRPORTS

2.3.1 Tabulated below are details of aerodrome characteristics of Singapore Changi Airport and Paya Lebar Airport which indicate the similarities and significant differences for ease of identification by pilots operating into these two airports.

Aeronautical Service	PAYA LEBAR Airport	SINGAPORE CHANGI Airport	Significant Remarks and Differences
Magnetic heading of RWY	02/20	02L/20R 02C/20C 02R/20L	Exercise caution due to similar RWY alignment
Approach Lights	RWY 02 Modified Calvert High INTST with centreline and 3 crossbars. High INTST white LGT with brilliancy control and sequenced flashing lights.	RWY 02L Precision APCH LGT CAT II. Extended centreline with red side row barettes, 2 crossbars, 2 APCH beacons and sequenced flashing lights.	
	RWY 20 Modified Calvert High INTST with centreline and 3 crossbars. High INTST white LGT with brilliancy control and sequenced flashing lights.	RWY 20R Precision APCH LGT CAT I. Centreline barettes flashing white, 2 APCH beacons and sequenced flashing lights. (refer to chart AD-2-WSSS-ADC-2)	
ILS	RWY 20 - NIL	RWY 20R IDENT ICH No back beam LLZ 108.9 MHz GP 329.3 MHz	
	RWY 02 - NIL	RWY 02L IDENT ICW No back beam LLZ 110.9 MHz GP 330.8 MHz	
IBN	Flashing R 'PL' HN and IMC	Flashing G 'SS' HN and IMC	
ABN	NIL	ALTN Flashing W G every 2.3 SEC	

WSSS AD 2.21 NOISE ABATEMENT PROCEDURES

1.1 To alleviate the problem of noise, all aircraft on AWY G579 between SINJON (SJ) and GUMPU shall operate at/above 5,000ft.

1.2 The Standard Instrument Departure routes for aircraft departing on RWY 20R/20C/20L are for the purpose of noise abatement in addition to being used for air traffic control.

1.3 Departures on RWY 20R are restricted between 1600-2200UTC. This restriction is not applicable when RWY 20C/02C and RWY 20L/02R are unavailable because of maintenance works or for other reasons.

1.4 Unless it is necessary for operational or safety reasons, when using engine reverse, arrivals on RWY 02L/20R between 1600-2200UTC may not exceed idle reverse thrust.

WSSS AD 2.22 FLIGHT PROCEDURES

1 LOW VISIBILITY PROCEDURES (LVP) FOR CATEGORY II ILS OPERATIONS

1.1 Introduction

1.1.1 Category II ILS approaches will be made available at Singapore Changi Airport to authorised flights during prolonged periods of low visibility, except during thunderstorms. RVR minima for CAT II ILS operations is limited to 350m due to runway and taxiway light spacing requirements on the airfield.

1.2 Authorisation for Category II ILS Approaches

1.2.1 Operators who wish to conduct Category II ILS operations at Singapore Changi Airport must have obtained operational approval from the relevant State of Operator and be authorised by the Civil Aviation Authority of Singapore.

1.3 Category II ILS Runways

1.3.1 At Singapore Changi Airport, Category II ILS approaches are available only on RWY 02L and RWY 20C, which are also equipped with precision approach Category II lighting system. When required, pilots making Category II ILS approaches to Singapore Changi Airport should refer to the procedures in the Instrument Approach Charts AD-2-WSSS-IAC-1 to AD-2-WSSS-IAC-11 and the Precision Approach Terrain Charts for RWY 02L and RWY 20C at AD-2-WSSS-PATC-1 and AD-2-WSSS-PATC-2 respectively.

1.4 Initiation of Category II ILS Operations

1.4.1 Preparations will be made to implement LVP for Category II ILS operations at Singapore Changi Airport during prolonged period of low visibility, except during thunderstorms, when the RVR drops below 800 metres.

1.4.2 Availability of the Category II ILS approaches will be made known through NOTAM and ATIS broadcasts as well as air traffic control radio communications.

1.4.3 During LVP operations, aircraft will not be cleared for Category II ILS approach if any of the ILS or approach/runway lights fall below Category II requirements. Aircraft will not be cleared for landing if the Touchdown Zone RVR is unserviceable.

1.5 ILS Sensitive Areas

1.5.1 Upon landing, pilots shall report to Changi Tower once the aircraft has cleared the runway and has passed the ILS sensitive areas demarcated by alternate yellow and green lights along the centrelines of Rapid Exit Taxiways and Cross Taxiways.

1.6 Termination of LVP for Category II ILS Operations

1.6.1 LVP for Category II ILS operations will be terminated when RVR has improved above 800 metres. Termination of LVP for Category II ILS operations will be made known through NOTAM and ATIS broadcasts as well as air traffic control radio communications.

1.7 Operations of flights Not Authorised for Category II ILS Operations

1.7.1 During Category II ILS operations, if the RVR is 550 metres or above, flights not authorised for Category II ILS operations may continue to make approaches and land. Airlines planning to operate flights not authorised for Category II ILS operations into Changi shall monitor the METAR to ascertain the RVR values when launching their flights and be prepared to divert if the RVR is below 550 metres.

2 RUNWAY UTILISATION

2.1 Runway-in-use

2.1.1 The runway-in-use (Departure/Arrival) is selected by Aerodrome Control as the optimum for general purposes and to maximise runway utilisation. If the assigned runway is unsuitable for a particular operation, the pilot can obtain permission from ATC to use another runway but should anticipate delay.

2.2 Departures

2.2.1 Pilots should arrange their taxi such that they are ready to depart without delay on reaching the runway holding point. As standard ICAO wake turbulence separation is being applied, pilots are to advise ATC early if more time is needed for the aircraft to be ready for departure. When informed, ATC will be able to make changes in the departure sequence, if necessary, to minimise delays to other succeeding departures.

2.2.2 Pilots should complete cockpit checks prior to line-up for departure and keep any checks on the runway to a minimum.

2.2.3 Conditional line-up clearance may be used by ATC to facilitate an expeditious flow of traffic. On receipt of line-up clearance, pilots should taxi into position promptly without delay. Unless given instructions to line-up and wait, pilots should be ready and prepared to depart without stopping. On receipt of take-off clearance, pilots to commence take-off roll without delay.

2.3 Clearance for Immediate Take-Off

2.3.1 A pilot receiving the ATC instruction 'cleared for immediate take-off' is required to act as follows:

- a) if waiting clear of the runway, taxi immediately on to it and begin take-off run immediately without stopping the aircraft;
- b) if already lined-up on the runway, take-off without delay;
- c) if unable to comply with the instruction, inform ATC immediately.

2.4 Arrivals - Minimum Runway Occupancy Time (ROT)

2.4.1 Arriving aircraft upon landing are reminded that it is imperative to vacate the runway as quickly as practicable to enable ATC to apply minimum spacing on final approach and minimise the occurrence of "go-arounds".

2.4.2 To achieve minimum ROT and reduce missed approaches due to occupied runway, pilots should vacate the runway via the first available exit taxiway corresponding to operational requirements, or as instructed by ATC. If an exit taxiway other than the first available exit taxiway is required, pilots shall advise the Tower Controller on first contact.

2.4.3 To enhance planning, pilots can make reference to the Landing Exit Distance (LED), information below which is measured from threshold to tangent point where the exit taxiway centreline starts to curve away from the runway centreline:

RWY	Exit Taxiway (LED in metres)	Remarks
20R	<u>W6*(1655)</u> , <u>W7*(2123)</u> and W8(3061)	Note 1: Recommended exit taxiways are bold and underlined.
20C	<u>T7*(1924)</u> , <u>T8*(2375)</u> , <u>D8*(1750)</u> , <u>D9*(2225)</u> and D10*(2700)	Note 2: * Indicates Rapid Exit Taxiway (RET) and maximum design ground speed for the exit taxiway is 50kts.
20L	<u>A7*(1750)</u> , <u>A8*(2225)</u> , and A9*(2700)	
02L	<u>W5*(1996)</u> , <u>W4*(2491)</u> and W3*(2876)	
02C	<u>T6*(2040)</u> , <u>T5*(2545)</u> , T4*(3245) <u>D7*(1900)</u> , <u>D6*(2375)</u> and D5*(2850)	
02R	<u>A6*(1900)</u> , <u>A5*(2375)</u> and A4*(2850)	

2.4.4 Pilots can expect initial taxi instructions from the Runway Controller before clearing the exit taxiway. Aircraft vacating the runway-in-use should not stop on the exit taxiway until the entire aircraft has passed the runway holding point.

2.4.5 BTN 0830-1030 daily estimated delays of about 15 minutes can be expected for arrivals into Singapore Changi Airport.

2.5 Reduced Runway Separation Minima

2.5.1 Reduced Runway Separation Minima may be applied between a departing aircraft and a succeeding landing aircraft or between two successive landing aircraft on the same runway provided the following conditions exist:

- a) During the hours of daylight from 30 minutes after local sunrise to 30 minutes before local sunset;
- b) Visibility of at least 5km;
- c) Cloud ceiling shall not be lower than 1,000ft;
- d) Tailwind component shall not exceed 5 knots;
- e) The second aircraft will be able to see the first aircraft clearly and continuously until the first aircraft is clear of the runway;
- f) Traffic information shall be provided to the flight crew of the succeeding aircraft concerned;
- g) The braking action shall not be adversely affected by runway contaminants such as water;
- h) Wake turbulence separation minima shall be applied; and
- i) Responsibility for ensuring adequate separation between the two aircraft rests with the pilot of the second aircraft.

2.5.2 When reduced Runway Separation Minima is applied, the successive landing aircraft may be given a clearance to land before the first aircraft has cleared the runway-in-use after landing or crossed the runway end on departure provided there is reasonable assurance that the following separation distances will exist when the landing aircraft crosses the runway threshold:

	Landing following Landing	Landing following Departure
RWY 02L/20R	The preceding aircraft has landed and has passed a point at least 2500m from the threshold of runway (abeam TWY W4 for RWY 02L or TWY V8 for RWY 20R), is in motion and will vacate the runway without backtracking.	The departing aircraft is/will be airborne and has passed a point at least 2500m from the threshold of the runway (abeam TWY W4 for RWY 02L or TWY V8 for RWY 20R).
RWY 02C/20C	The preceding aircraft has landed and has passed a point at least 2500m from the threshold of the runway (abeam TWY T5 for RWY 02C or TWY T8 for RWY 20C), is in motion and will vacate the runway without backtracking.	The departing aircraft is/will be airborne and has passed a point at least 2500m from the threshold of the runway (abeam TWY T5 for RWY 02C or TWY T8 for RWY 20C).
RWY 02R/20L	The preceding aircraft has landed and has passed a point at least 2500m from the threshold of the runway, (abeam TWY A5 for RWY 02R or TWY A8 for RWY 20L) is in motion and will vacate the runway without backtracking.	The departing aircraft is/will be airborne and has passed a point at least 2500m from the threshold of the runway (abeam TWY A5 for RWY 02R or TWY A8 for RWY 20L).

2.6 Phraseology

2.6.1 When issuing a landing clearance following the application of these procedures, ATC will issue the second aircraft with the following instructions:

".... (call sign) after the landing / departing (Aircraft Type) Runway(Designator) cleared to land".

3 AIRPORT COLLABORATIVE DECISION MAKING (A-CDM) MODE OF OPERATIONS

3.1 A-CDM aims to optimise airport operations by having an efficient turnaround process and improving the predictability of operational events. It also helps to improve gate management, flight punctuality, reduce apron taxiway and holding point congestion which is beneficial to all airport partners. A-CDM involves sharing of accurate and timely operational information amongst airport partners through different airport systems and improving work processes by implementing a set of operational procedures.

3.2 The A-CDM procedures apply to all scheduled flights departing Singapore Changi Airport except for VVIP, CASEVAC, SAR and aircraft on special tasks. ATC shall have full discretion in conduct of such operations.

3.3 Definition of commonly used terms in A-CDM

- Target Off Block Time (TOBT) – The time an aircraft operator (AO) or ground handling agent (GHA) estimates that an aircraft will be ready, all doors closed, boarding bridge removed, pushback vehicle available and ready to start-up / pushback immediately upon receipt of clearance from ATC.
- Target Start Up Approval Time (TSAT) – The time provided by ATC that an aircraft can expect start-up / push back approval.
- Calculated Take Off Time (CTOT) – A time calculated as a result of tactical slot allocation, at which a flight is expected to become airborne.

4 A-CDM PRE-DEPARTURE PROCEDURES

4.1 Singapore Changi Airport's A-CDM portal will automatically calculate a system TOBT for each departure flight taking into account the estimated or actual in-block time (EIBT / AIBT), minimum turnaround time (MTT) and scheduled time of departure (STD)

4.2 If the calculated TOBT (EIBT / AIBT + MTT) is earlier than STD, the system will take the STD as TOBT.

4.3 If the calculated TOBT (EIBT / AIBT + MTT) is later than STD, the amount of turnaround delay that system predicts is equal to TOBT – STD.

4.4 AO are required to assess the system generated TOBT at 40 minutes prior to departure and update it if the prediction of departure readiness is different. Thereafter, TOBT needs to be monitored and updated constantly if it is expected to differ by 5 minutes or more until the flight commences pushback. AO can consider delegating the responsibility of TOBT submission to their ground handling agent (GHA) subject to prior internal arrangements between AO and GHA.

4.5 TOBT shall be updated through the following systems:

- Airport Operations Centre System (AOCS) A-CDM web based portal; or
- Gate Message Input Display (GMID) at boarding rooms;

4.6 AO/GHA is encouraged to update TOBT through ONLY one of the above systems in order to avoid any chance of a miscommunication.

4.7 TOBT information is available through the following channels:

- a) AOCS A-CDM portal;
- b) GMID;
- c) Aircraft Docking Guidance System (ADGS) at contact stands;
- d) Radio communication with GHA or AO.

4.8 The Pre-Departure Sequencer (PDS) will calculate the TSAT automatically by taking into account factors such as TOBT, calculated take-off time (CTOT), variable taxi times (VTT), wake turbulence category, departure separation, etc. A pre-departure sequence is determined from the calculated TSATs, thus the accuracy of TOBT is vital to an optimal TSAT.

4.9 Flights with an invalid or expired TOBT will be instructed by ATC to update TOBT when requesting for clearance. For non-compliant flights, delays can be expected. AO or GHA are strongly encouraged to update TOBT as soon as any expected delay to the aircraft readiness for pushback is made available to avoid unnecessary hold-ups.

4.10 TSAT information is available through the following channels:

- a) AOCS A-CDM portal;
- b) GMID;
- c) ADGS at contact stands;
- d) Radio communication with GHA or AO;
- e) ATC - Upon issuance of ATC clearance (for flights parked at aircraft stands without ADGS).

5 A-CDM START-UP PROCEDURES

5.1 Pilot shall ensure aircraft is ready for pushback at TOBT.

5.2 Pilot to maintain communication with the AO / GHA as they are responsible for updating the TOBT. Notify the AO / GHA to update the TOBT if it is expected to differ by 5 minutes or more.

5.3 Pilot utilising the DCL service on selected routes shall request for ATC clearance through 'Request for Departure Clearance Downlink' (RCD) message no earlier than 20 minutes before TOBT. Refer to WSSS AD 2.22 paragraph 8.4 on the applicable routes for DCL service and procedures.

5.4 Pilot using voice request to contact Ground Movement Planner (Clearance Delivery) and request for ATC clearance within 5 minutes of TOBT using the following phraseology:

- Callsign
- Destination
- Proposed flight level and alternate level, if any
- Parking position

a) Pilot shall only request for ATC clearance provided aircraft is ready to pushback at TOBT.

5.5 Regardless of clearance through voice or datalink, all departing aircraft must report to Clearance Delivery when ready for push within 5 minutes of TOBT.

5.6 ATC will advise the pilot whether the proposed flight level or other alternate flight level is available and an ATC clearance will be issued accordingly. If pre-departure coordination with an adjacent unit or centre is required, the pilot will be instructed to standby.

5.7 ATC will update TSAT changes if any, during issuance of ATC clearances. Note that TSAT displayed on ADGS may not be final and can be revised due to en-route clearance restrictions, ground congestion or flow measures.

5.8 Pilot shall request for pushback from Ground Movement Control within 5 minutes of TSAT after obtaining ATC clearance, or as directed by ATC.

- a) ATC may swap pushback sequence based on real-time readiness of aircrafts to maximise apron and runway capacity and reduce the overall delay to traffic as and when required.
- b) At the end of pushback, the departing aircraft must be ready to taxi immediately, unless otherwise instructed by ATC.

Note: The first aircraft to taxi may not necessarily be the first aircraft to take-off as distances between aircraft stands and the departure runway vary.

5.9 If a flight is unable to pushback by TSAT + 5 minutes due to the aircraft being unready, ATC clearance and TSAT will be cancelled. Pilot must notify the AO / GHA to update the TOBT for a new TSAT before requesting for a new ATC clearance. This also applies to aircraft returning back to blocks after pushback.

- a) ATC will inform the aircraft when a clearance is cancelled using the phraseology; "(Callsign of aircraft) your ATC clearance and TSAT is cancelled (reason). Update TOBT before requesting for new clearance".
- b) Flight may also have its ATC clearance cancelled if it develops a technical problem after pushback and is unable to taxi for prolonged duration.

5.10 Non-compliance of initial TSAT may result in an aircraft losing its existing position in the pre- departure sequence. Delay can be expected as a result of re-sequencing based on new TOBT input.

5.11 If delay in pushback is due to ground traffic movement or ATC clearance restrictions, the ATC clearance and TSAT will remain valid even if it exceeds TSAT + 5 minutes. TOBT need not be updated for such situations.

5.12 In the event that A-CDM mode of operations need to be cancelled due to any reason, the termination will be communicated to relevant parties through email by the airport operator and a NOTAM will be issued by ATC. Pilot shall follow the non-CDM procedures detailed in para 13.

5.13 Quick overview of WSSS start-up for pilots

Definitions of commonly used terms

- **Target Off-Block Time (TOBT)** - The time that an AO or GHA estimates that an aircraft will be ready, all doors closed, boarding bridge removed, pushback vehicle available and ready to start-up / pushback immediately upon receipt of ATC clearance.
- **Target Start-up Approval Time (TSAT)** - The time provided by ATC that an aircraft can expect start-up / pushback approval.

TOBT and TSAT requirements

- Irrespective of the TSAT, the aircraft must be ready for departure at the TOBT +/- 5 minutes as the TSAT may be revised forward at short notice.
- Any time the TOBT or TSAT cannot be met, or an earlier departure is required, the TOBT must be updated expeditiously by the aircraft operator or ground handler.

ATC Clearance





- ATC Clearance on selected ATS routes can be requested via Data Link Departure Clearance (DCL) at TOBT- 20 minutes.
- If DCL is not available, ATC Clearance should be requested via Clearance Delivery at TOBT +/-5 minutes.



Start-up / Pushback Clearance

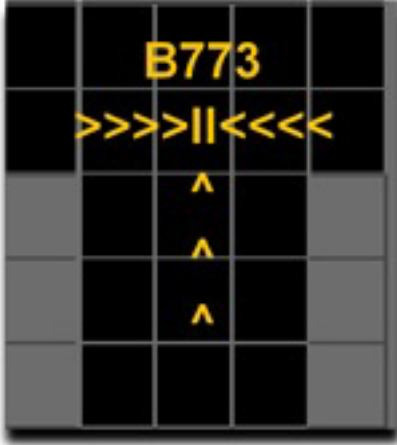

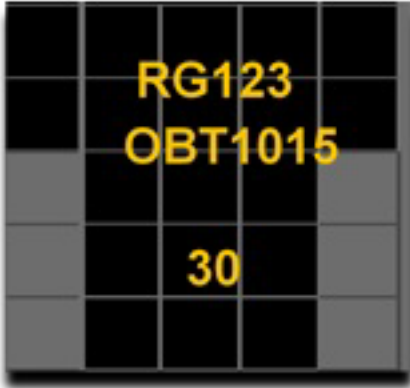
- Pilots must be ready for start-up / pushback at TOBT +/- 5 minutes.
- Pilots should request start-up / pushback clearance at TSAT +/- 5 minutes.

6 A-CDM INFORMATION VIA AIRCRAFT DOCKING GUIDANCE SYSTEM (ADGS)

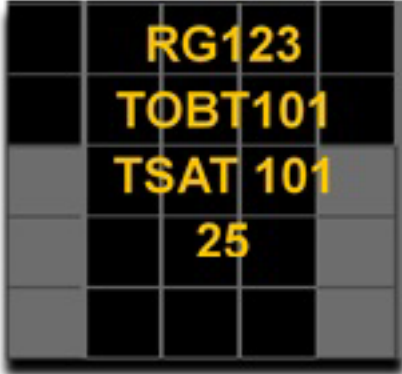
6.1 All contact stands in Singapore Changi Airport will have ADGS. The fundamental operation and usage of ADGS still remain the same for flight crew. Additional information which includes TOBT, TSAT and TOBT count-down timer will be displayed in local times as part of the improvements to support A-CDM operations.

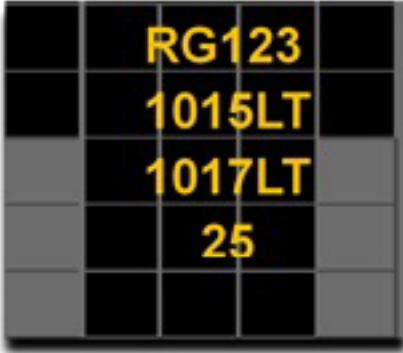
Aircraft Docking Guidance System (ADGS)	
Description	Display on ADGS
<p>Aircraft arrival to stand</p> <ul style="list-style-type: none"> No change in existing functionality and display 	
<p>40 minutes prior to TOBT</p> <ul style="list-style-type: none"> ADGS will display TOBT submitted by AO / GHA and a count down timer (2 digits) to TOBT in minutes As ADGS can only display up to 7 characters per line, the displayed message will be scrolling. Timings displayed will be in Local Time (LT) TOBT timings will change instantly if there is an update done by AO / GHA 	<div style="display: flex; justify-content: space-around;"> <div style="text-align: center;"> <p>Snapshot 1</p>  </div> <div style="text-align: center;"> <p>Snapshot 2</p>  </div> </div> <div style="text-align: center; margin-top: 20px;"> <p>Snapshot 3</p>  </div>

Aircraft Docking Guidance System (ADGS)	
Description	Display on ADGS
<p>25 minutes prior to TOBT</p> <ul style="list-style-type: none"> ADGS will display TSAT derived by PDS As ADGS can only display up to 7 characters per line, the displayed message will be scrolling. TSAT timings may change as the PDS is continuously optimising push back times based on real time traffic conditions 	<div style="display: flex; justify-content: space-around;"> <div style="text-align: center;"> <p>Snapshot 1</p>  </div> <div style="text-align: center;"> <p>Snapshot 2</p>  </div> </div> <div style="text-align: center; margin-top: 20px;">  <p>Snapshot 3</p> </div>

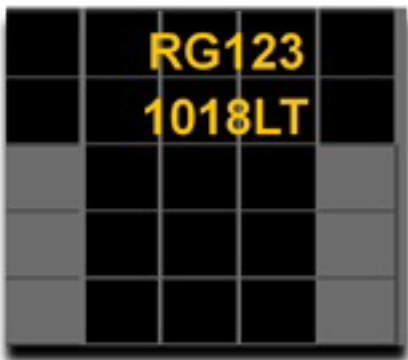
Aircraft Docking Guidance System (ADGS)	
Description	Display on ADGS
<p>Aircraft departure from stand</p> <ul style="list-style-type: none"> – ADGS will display the actual off-block time (AOBT) – As ADGS can only display up to 7 characters per line, the displayed message will be scrolling – TOBT, TSAT and TOBT countdown timer will be removed – AOBT display will be removed 3 minutes after AOBT 	<div style="display: flex; justify-content: space-around; align-items: flex-start;"> <div style="text-align: center;"> <p>Snapshot 1</p>  </div> <div style="text-align: center;"> <p>Snapshot 2</p>  </div> </div> <div style="text-align: center; margin-top: 20px;">  <p>Snapshot 3</p> </div>

7 CONTACT AND INFORMATION

7.1 Please contact the airport operator, Changi Airport Group (CAG), at a-cdm@changiairport.com for application of AOCS A-CDM and GMID account or if you have any queries.

7.2 Aircraft operators may also contact their ground handling agent directly on queries regarding TOBT submission.

8 DEPARTURE CLEARANCE (DCL) VIA DATALINK PROCEDURES

8.1 Aircraft need to be equipped with Aircraft Communications Addressing and Reporting System (ACARS) to support DCL application and be compliant with the European Organisation for Civil Aviation Equipment (EUROCAE) ED-85A (Data Link Application System Document (DLASD) for the DCL datalink service) and ARINC Specification 623-3.

8.2 Singapore application of DCL is in accordance with ED-85A.

8.3 The logon ID of the ground system for the provision of DCL service is WSSS.

8.4 DCL service is only applicable for flights departing from WSSS to the following routes / destinations:

- a) Destinations in Peninsular Malaysia via ATS Routes A457 and B466
- b) Destinations in Thailand via ATS Routes B466 and B469 / M751
- c) Destinations in Indonesia via ATS Route A457, R469 and B470
- d) Destinations in Australia and New Zealand via ATS Route B470
- e) Flights with allocated Calculated Take-Off Time (CTOT) under Bay of Bengal Cooperative Air Traffic Flow Management (BOBCAT)

8.5 Pilot utilising the DCL service on selected routes shall request for ATC clearance through RCD message no earlier than 20 minutes before TOBT.

- a) For flights with allocated CTOT under BOBCAT, to input "CTOT HHMMz" under the free text field in RCD message.
- b) For flights routed via ANITO B470, to input "ANITO FLxxx"(ANITO crossing level) under the free text field in RCD message.
- c) Pilot shall contact Clearance Delivery or the next assigned frequency in 'Departure Clearance Uplink' (CLD) message within 5 minutes of TOBT using the following phraseology:
 - <"Callsign"...With P-D-C, fully ready>
 - Provide requested flight level if it differs from PFL filed in flight plan
 - Provide CTOT or ANITO crossing if not previously given in RCD message

8.6 DCL message format does not include the requested cruising level and final cruising level.

- a) The planned flight level (PFL) filed in flight plan field 15b will be used as requested level unless otherwise specified by pilot.
- b) Final cruising level will be assigned by Singapore ATC after airborne and it is subjected to traffic disposition. No on-ground level negotiations or reservations are allowed.

8.7 DCL service does not provide clearance revision. Any revision to the clearance issued via datalink will be made by ATC through voice communications.

8.8 Clearance request through VHF using the existing voice procedures is still available for applicable flights under the DCL service.

8.9 ATC will reject the DCL request and send a "revert to voice procedures" message to the pilot if one of the following occurs:

- a) Flight's routes / destinations not stated in paragraph 8.4
- b) RCD message does not comply with ED-85A or have inaccurate flight data, e.g. different Callsign / ADES from flight plan
- c) Invalid TOBT
- d) When required by ATC due to flow restriction

8.10 Upon receipt of any "revert to voice procedures" message, pilot shall cancel any clearance received previously (if any) and follow the existing voice procedures for clearance request, i.e. contact Clearance Delivery within 5 minutes of TOBT.

8.11 Pilot shall monitor the clearance delivery frequency once the DCL process is initiated. In the event of any issues encountered, ATC will revert to voice procedures.

8.12 ATC will revert with CLD message within 5 minutes of receipt of the RCD message. If no CLD message is received, pilot is to call on delivery frequency to verify request.

8.13 Pilot shall respond with 'Departure Clearance Readback Downlink' (CDA) message within 5 minutes of receipt of CLD message. Failure to comply may result in a "revert to voice procedures" message being sent.

Note: The DCL process is only complete and clearance confirmed when CDA message is received and processed successfully. A "CDA received – clearance confirmed" message will be sent to the pilot.

8.14 Aircraft operator / ground handling agent shall continue to update TOBT to reflect any changes in readiness time in accordance to A-CDM startup procedures stated in AIP Singapore section WSSS AD 2.22 paragraph 5.

8.15 ATC will check for TOBT compliance and update pilot of any revisions in departure clearance and flow restrictions before handing the flight over to Ground frequency for start-up and pushback.

8.16 ATC will cancel the clearance issued and send a "revert to voice procedures" message if pilot does not report ready for push within 5 minutes of TSAT.

9 ASSIGNMENT OF FLIGHT LEVELS TO AIRCRAFT DEPARTING FROM SINGAPORE CHANGI AIRPORT

9.1 Assignment of flight levels to departing aircraft is made on a best-planned-best-served basis (with reference to TOBT for ATC clearance request detailed in para 5.4). Aircraft will normally be assigned the level requested unless an alternate level is offered after coordination with the adjacent ATC centres.

9.2 Aircraft departing Singapore requesting FL280, FL300 or FL320 on ATS routes L510, L759, L515/M770, N571, N571/N877, P628 or P574:

- a) Aircraft will be assigned No-PDC FL280.
- b) Succeeding aircraft on the same ATS route will be assigned No-PDC FL280 with 10-minute longitudinal separation behind provided there is no closing speed with the preceding aircraft.
- c) If the succeeding aircraft is faster than the preceding aircraft, additional longitudinal separation as appropriate shall be imposed by ATC.

9.2.1 For aircraft on ATS routes L510, N571, P574 or P628 that are equipped with Automatic Dependent Surveillance – Contract (ADS-C) and Controller-Pilot Data Link Communication (CPDLC):

- a) Succeeding aircraft on the same ATS route will be assigned No-PDC FL280 with 7-minute longitudinal separation behind and provided there is no closing speed with the preceding aircraft.
- b) If the succeeding aircraft is faster than the preceding aircraft, additional longitudinal separation as appropriate shall be imposed by ATC.

10 DELAY IN PUSHBACK AND/OR TAXIING DUE TO OTHER AIRCRAFT

10.1 Delays may be expected for the second aircraft to pushback and to taxi when two or more aircraft are parked either adjacent to one another or close together. However, it will retain its ATC clearance even if the 5 minutes grace period allowed for under para 5.9 is exceeded.

Note: The TSAT may not be able to predict delays arising from apron congestion as traffic movement on ground is dynamic and situations may change on a real time basis depending on aircraft readiness. ATC will facilitate pushback as soon as possible when traffic permits.

11 DELAY IN TAKE-OFF DUE TO RESTRICTIONS IN THE ATC CLEARANCE

11.1 The ATC clearance may require an aircraft to arrive at a reporting point at a specified time and level or to depart a number of minutes behind a preceding traffic to establish the appropriate longitudinal separation. Such delay will not deprive a departing aircraft of its ATC clearance even though the 5 minutes grace period allowed for under para 5.9 is exceeded.

12 DELAY DUE TO OVERFLIGHTS

12.1 Overflights are flights that traverse Singapore FIR and/or airspace within the Jakarta FIR where ATS is provided by Singapore (see ENR 2.1) without landing at Singapore Changi Airport. Depending on the positions of overflights, a departing aircraft requesting the same flight level may have to accept an alternate flight level or delay its departure in order to establish the prescribed separation.

13 NON-CDM MODE OF OPERATIONS

13.1 The non-CDM procedures is applicable for non-scheduled flights departing Changi Airport or when TOBT and TSAT references used in A-CDM mode of operations become unavailable due to system issues or maintenance.

13.2 If TOBT cannot be submitted or it is unavailable through different channels stated in para 4.5,

- a) Pilots shall notify ATC when the aircraft is ready to pushback within 5 minutes.
- b) ATC will advise the pilot whether the proposed flight level or other alternate flight level is available and an ATC clearance will be issued accordingly. If pre-departure coordination with an adjacent unit or centre is required, the pilot will be instructed to standby.
- c) Once flight level is accepted by the pilot and an ATC clearance issued, the aircraft must be pushed back within 5 minutes from the time the ATC clearance is accepted unless other ATC restrictions are imposed. The ATC clearance will be cancelled on expiry of the 5 minutes grace period. This also applies to situations when aircraft return to blocks after pushback or develop technical issues and is unable to continue taxi.
- d) Pilots who are ready to depart following the cancellation of an ATC clearance will adopt the procedures as if it is the first time they are ready to depart.

13.3 If TSAT is unavailable through different means stated in para 4.10,

- a) AO and GHA shall continue to submit TOBT and pilots shall request for ATC clearance 5 minutes within TOBT stated in para 5.4
- b) ATC will revert to the gate hold procedures stated in para 14 and issue estimated pushback times accordingly.

14 GATE HOLD PROCEDURES FOR DEPARTING AIRCRAFT (DURING NON-CDM MODE OF OPERATIONS)

14.1 Whenever there are about five to seven departing aircraft at the runway holding point, subsequent pushback of departures will be regulated such that the Ground Movement Planner (GMP) on VHF frequency 121.65MHz will start to issue pilots with Expected Pushback Time (EPT) as TSAT used in A-CDM operations is not available. The determination of EPT will take into account an aircraft's parking stand as well as taxi time to the runway-in-use holding point.

14.2 When an EPT is issued, pilots will be instructed to either remain on GMP frequency or to monitor Singapore Ground Control (frequencies 121.725MHz, 121.85MHz, 122.55MHz, 124.3MHz or 125.65MHz). It should be noted that when instructed to monitor the Singapore Ground frequencies, pilots shall not establish contact with the Singapore Ground Control, rather, pilots shall maintain listening watch on the assigned Singapore Ground Control frequency and wait for pushback instruction. This is to prevent unnecessary frequency congestion.

14.3 A flight issued with an EPT but chooses to commence pushback before the assigned time will be allowed to do so subject to traffic. However, the flight should not expect an earlier departure time as the planned pre-departure sequence will be maintained.

14.4 In a situation when a departing aircraft is occupying a gate that has been assigned to an arriving aircraft, the departing aircraft will be instructed by GMP to contact Singapore Ground Movement Control for pushback for the purpose of better gate utilisation.

14.5 To maximise runway utilisation, departure sequence will be planned on the basis of increasing runway throughput so as to enhance overall efficiency.

15 GROUND MOVEMENT PLANNER ON VHF 121.65MHz

15.1 The frequency shall be used for aircraft pre-flight checks and ATC clearances. Pilot-in-command to make his initial call from the parked position on this frequency.

16 GROUND MOVEMENT CONTROL ON VHF 121.725MHz, 121.85MHz, 122.55MHz, 124.3MHz, 125.65MHz AND 127.275MHz

16.1 This frequency shall be used for aircraft start-up/push-back clearance.

16.2 Unless otherwise instructed by ATC, the pilot-in-command shall prior to starting engines listen out on the Ground Movement Control frequency on 121.725MHz, 121.85MHz, 122.55MHz, 124.3MHz or 125.65MHz.

16.3 The pilot-in-command shall:

- a) Request and obtain taxi instructions prior to taxiing;

Note: ATC clearance, including the assigned SSR code will normally be issued prior to push back. Pilot shall squawk the SSR code immediately when airborne.

- b) Change from Ground Movement Control frequency to the Runway Control frequency when instructed (118.6MHz, 118.25MHz or 131.4MHz). It should be noted that when instructed to monitor Singapore Tower frequencies, pilots shall not establish contact with Singapore Tower; rather, pilots shall maintain a listening watch on the assigned Singapore Tower frequency and wait for instruction. This is to prevent unnecessary frequency congestion.

16.4 Departing aircraft will be instructed when to change from 118.6MHz, 118.25MHz or 131.4MHz to Singapore Departure frequency 120.3MHz.

16.5 In the case of the aircraft having landed, the pilot-in-command shall change from 118.6MHz, 118.25MHz or 131.4MHz to 121.725MHz, 121.85MHz, 122.55MHz, 124.3MHz, 125.65MHz or 127.275MHz immediately upon instructed by ATC after clearing the runway. He shall maintain watch on 121.725MHz, 121.85MHz, 122.55MHz, 124.3MHz, 125.65MHz or 127.275MHz for taxiing and parking instructions until he arrives at his aircraft stand.

17 TAXIING

17.1 Taxi clearance given by Singapore Ground Movement Control will relate to movement on the manoeuvring area, but excluding the marshalling area.

17.2 Aircraft taxiing on the manoeuvring area will be regulated by ATC to avoid or reduce possible conflict and will be provided with traffic information and alerting service. ATC shall apply taxiing clearance limits whenever necessary.

17.3 The taxiway routes to be used by aircraft after landing or when taxiing for departure will be specified by ATC. The issuance by ATC of a taxi route to an aircraft does not relieve the pilot-in-command of the responsibility to maintain separation with other aircraft on the manoeuvring area or to comply with ATC directions intended to regulate aircraft on the manoeuvring area. **Pilots are also advised of the possibility of misjudging the clearance between the aircraft wing tips and other obstacles, especially in areas of hot-spots or during low-light / poor visibility conditions.**

17.4 Pilots are reminded to always use minimum power when starting engines, when manoeuvring within the apron area or when manoeuvring from apron taxiways to other parts of the aerodrome. It is especially critical when commencing to taxi that break-away thrusts are kept to an absolute minimum and then be reduced to idle thrusts as soon as possible.

17.5 TWY K (north of RWY 02C/20C) and TWY L (south of RWY 02C/20C) are End-Around Taxiways to facilitate aircraft movement between the east and west of RWY 02C/20C. Aircraft taxiing on these taxiways will be regulated by ATC to avoid conflict with aircraft operating on RWY 02C/20C.

18 TAKE-OFF AND LANDING

18.1 Departing aircraft will normally be directed by ATC to use the full length of the runway for take-off. On obtaining an ATC clearance the aircraft shall enter the runway via designated taxiways:

RWY 02R – TWY A10, A11 or A12

RWY 02C - TWY T12, T13, D13, D14

RWY 02L - TWY W8, W9 or W10

RWY 20L – TWY A1, A2 or A3

RWY 20C - TWY T1, T2, D1, D2

RWY 20R - TWY W1, W2

18.2 The pilot-in-command shall not take-off or land without a clearance from Aerodrome Control.

18.3 The pilot-in-command shall not run-up on the runway in use unless authorised by Aerodrome Control. Engine run-ups in the holding pan or taxiway holding point clear of the runway in use may be carried out subject to approval by Aerodrome Control.

18.4 After landing, the pilot-in-command shall vacate the runway by the shortest suitable route and to contact Singapore Ground Movement Control who will issue specific taxi route instructions to its assigned aircraft stand.

18.5 Aircraft with radio communication failure shall vacate the runway and stop on the taxiway and watch for light signals from Aerodrome Control.

19 STANDARD INSTRUMENT DEPARTURE (SID) AND STANDARD INSTRUMENT ARRIVAL (STAR)

19.1 INTRODUCTION

19.1.1 The SIDs and STARs for Singapore Changi Airport require aircraft to be GNSS-equipped and approved with navigation systems that meet the ICAO RNAV-1 navigation specification in accordance to the ICAO Performance Based Navigation Manual (Doc 9613).

19.1.2 To avoid proliferation of SIDs and STARs, the basic RNAV SIDs and STARs follow similar tracks as the RNAV-1 (GNSS) SIDs and STARs using the same set of SIDs and STARs identification.

19.1.3 Operators / pilots who are not approved to operate on the RNAV-1 (GNSS) SIDs and STARs shall notify ATC and operate on the alternate basic RNAV SIDs and STARs or expect radar vectors from ATC.

19.2 ARRIVALS

19.2.1 Arriving aircraft from the various ATS routes shall plan for the respective RNAV-1 STARs with the associated flight planning requirement as shown below:

ATS Route	RNAV-1 STAR	Remarks and Flight Planning Requirement
A464 (southbound to Singapore)	TEBUN	Arrivals into Changi to flight plan via A464 - ARAMA – TEBUN. After TEBUN, to join the TEBUN STAR. When traffic permits and WSSS Runway 20 is in use, ATC will offer LELIB STAR.
A576 (southbound to Singapore)	Not applicable	Southbound flight landing at WSSS are not permitted to flight plan via A576.
G579	REPOV	NIL
G580	KARTO	NIL
L504 / T22	UGEBO	Arrivals into Changi on L504 to flight plan via OBDOS – T22 – UGEBO. After UGEBO, to join the UGEBO STAR.
L642 ¹	ELALO	ESPOB Q801 Q802 ELALO / ESPOB DCT ELALO
L762	ASUNA	NIL
M635 / T23	UGEBO	Arrivals into Changi on M635 to flight plan via SURGA – T23 – UGEBO. After UGEBO, to join the UGEBO STAR.
M646	KARTO	NIL
Y514	Not applicable	Y514 NUFFA PIBAP PASPU. After PASPU, expect radar vectors.
M753	ELALO	IPRIX Q802 ELALO
M767	KARTO	NIL
M774 / T22		Arrivals into Changi on M774 to flight plan via OBDOS – T22 – UGEBO. After UGEBO, to join the UGEBO STAR.
M904	ELALO	UPRON Q803 ELALO
N891	ELALO	N891 ENREP DCT ELALO
N892 ¹	MABAL	MELAS DCT MABAL
R469	ASUNA	NIL

Note: The LEBAR STAR serves as a transition option to the STARs listed above. This is to facilitate arrivals joining downwind to the west of Singapore Changi Airport. ATC may clear arrivals to join the LEBAR STAR when air traffic permits.

¹Refer to ENR 1.3 and ENR 3.2 for Direct Routing Operations (DRO) flight planning procedures.

19.2.2 All RNAV-1 (GNSS) STARs terminate at the initial approach fix (IAF). Arrivals can expect radar vectors for approach to the respective runways.

19.3 DEPARTURES

19.3.1 All departing aircraft will be cleared on the appropriate RNAV-1 (GNSS) SIDs or radar departure to join the planned ATS route and shall climb initially to 3,000ft.

19.3.2 RNAV-1 (GNSS) SIDs will be assigned to departures from Singapore Changi Airport that flight plan on the following ATS routes:

ATS Route	RNAV-1 SID	Remarks and Flight Planning Requirements
A457	MASBO	NIL
B470	ANITO	NIL
G580 / M646	TOMAN	NIL
L625 / N884	TOMAN	NIL
L762	MIBEL	NIL
M751	MERSING	NIL
M753	MERSING	VMR L642 EGOLO DCT IPRIX ² Expect radar vectors or further ATC clearance on approaching VMR.
M771	MERSING	VMR DOLOX M771 Expect radar vectors or further ATC clearance on approaching VMR.
N884	Not applicable	Not available for flight planning between VMR and LUSMO. Flight plan via TOMAN L625 LUSMO N884.
N891	MERSING	VMR ENREP N891 Expect radar vectors or further ATC clearance on approaching VMR.
R469	TAROS	NIL
T21 / L504	DODSO	Departures joining ATS route L504 to flight plan via DODSO T21 OBDOS.
T21 / M774	DODSO	Departures joining ATS route M774 to flight plan via DODSO T21 OBDOS.
T24 / M635	IDBUD	Departures joining ATS route M635 to flight plan via IDBUD T24 SURGA M635.
W26	KIRDA	NIL
Y513	AROSO	Flight planning permitted for flights departing from or overflying Singapore to destinations north of Kuala Lumpur and Subang Airports. For flights operating at FL220 and below, to flight plan on A457.

²Refer to ENR 1.3 and ENR 3.2 for Direct Routing Operations (DRO) flight planning procedures.

19.4 VERTICAL AND SPEED RESTRICTIONS

19.4.1 Pilots shall comply with an ATC assigned level. Pilots shall also adhere to the vertical and speed restrictions depicted on the SIDs and STARs. ATC clearance will take precedence when the ATC clearance does not allow the pilots to adhere to the vertical and speed restrictions depicted on the SIDs and STARs.

19.5 OPERATORS' PROCEDURES

19.5.1 The operator shall ensure that in-flight procedures, crew manuals and training programmes are established in accordance with RNAV-1 (GNSS) navigation requirements.

19.5.2 Pilots shall inform ATC when on-board equipment does not meet the RNAV-1 (GNSS) navigation requirements. Pilots can then expect radar vector from ATC.

20 COORDINATES OF SID/STAR WAYPOINTS (WGS84 DATUM)

Name	Coordinates	Radius/Distance from VTK	Radius/Distance from SJ
ABVIP	010008.00N 1035032.00E	VTK R-203.5 / D27.0	SJ R-183.5 / D13.2
ADPON	010108.00N 1035808.00E	VTK R-163.1 / D13.4	SJ R-95.3 / D14.1
AGROT	010108.00N 1035808.00E	VTK R-187.7 / D24	SJ R-150.8 / D14.0
AGVAR	014719.00N 1034145.00E	VTK R-318.8 / D29.8	SJ R-344.3 / D35.3
AKMET	015355.00N 1034339.00E	VTK R-328.6 / D34.0	SJ R-349.3 / D41.3
AKOMA	014522.00N 1035443.00E	VTK R-342.0 / D21.4	SJ R-6.2 / D32.0
ALFA	013033.00N 1034942.00E	VTK R-295.7 / D12.9	SJ R-354.8 / D17.2
ANITO	001700.00S 1045200.00E	VTK R-153.4 / D113.4	SJ R-146.0 / D108.6
ARAMA	013654.00N 1030712.00E	VTK R-282.4 / D55.5	SJ R-298.0 / D50.0
AROSO	020846.00N 1032421.00E	VTK R-319.9 / D57.4	SJ R-334.0 / D61.7
ASITI	004906.00N 1035042.00E	VTK R-196.6 / D37.2	SJ R-181.3 / D24.1
ASOMI	010142.00N 1040207.00E	VTK R-178.1 / D23.1	SJ R-136.9 / D15.9
ASUNA	005948.00N 1030954.00E	VTK R-244.1 / D57.3	SJ R-252.0 / D43.6
ATLEX	010302.00N 1033331.00E	VTK R-232 / D-35.4	SJ R-240 / D20.5
ATRUM	013256.00N 1040057.00E	VTK R-357.3 / D8.0	SJ R-26.1 / D21.8
BETBA	013302.00N 1035331.00E	VTK R-316.1 / D11.3	SJ R-6.3 / D19.8
BIDUS	013554.05N 1035754.86E	VTK R-326.0 / D13.2	SJ R-6.9 / D22.6
BIPOP	013121.83N 1041018.03E	VTK R-54.5 / D11.0	SJ R-46.8 / D26.2
BISOV	004229.00N 1025214.00E	VTK R-238.6 / D81.1	SJ R-242.6 / D66.6
BITAM	010813.00N 1040757.00E	VTK R-158.3 / D17.9	SJ R-107 / D17.5
BOBAG	010230.00N 1032954.00E	VTK R-234.7 / D38.6	SJ R-243.2 / D24
BOKIP	010421.00N 1034353.00E	VTK R-220.5 / D27.0	SJ R-219.5 / D11.6
DODSO	012225.00N 1061402.00E	VTK R-91 / D154.3	SJ R-86.4 / D143.3
DOVAN	011938.00N 1041249.00E	VTK R-114.6 / D12.7	SJ R-73.9 / D22.5
DUBOT	010846.00N 1040103.00E	VTK R-181 / D16.1	SJ R-115 / D10.8
DUMUP	005430.00N 1035516.00E	VTK R-191.4 / D30.9	SJ R-167.9 / D19.2
ELALO	041240.00N 1043329.00E	VTK R-10.6 / D169.9	SJ R-13.4 / D183.3
EMRIX	012606.00N 1041040.00E	VTK R-83.0 / D9.4	SJ R-57.0 / D23.2
ERVIV	010445.00N 1041013.00E	VTK R-156.1 / D22	SJ R-114.3 / D20.8
GIXEM	004920.00N 1042539.00E	VTK R-145.5 / D43	SJ R-124.8 / D41.9
GOTGA	012013.00N 1044200.00E	VTK R-96.6 / D41	SJ R-82.3 / D51.3
GUMPU	013000.00N 1034243.20E	VTK R-285.1 / D19.3	SJ R-332.6 / D18.6
GUNUD	011042.00N 1050618.00E	VTK R-102.3 / D66.6	SJ R-92 / D75.2
GURES	002814.00N 1043835.00E	VTK R-146.4 / D67.5	SJ R-133.3 / D65.2
HOSBA	011947.80N 1042417.50E	VTK R-102.5 / D23.6	SJ R-79 / D33.7
IBASU	005751.00N 1033410.00E	VTK R-225.3 / D38.3	SJ R-228 / D23.1
IBIVA	011351.00N 1035637.00E	VTK R-203.1 / D12.0	SJ R-84.3 / D5.3
IBIXU	011621.00N 1035740.00E	VTK R-203.2 / D9.3	SJ R-64.4 / D7.0
IDBUD	001454.00N 1050139.00E	VTK R-139.1 / D92.2	SJ R-129.5 / D91.4
IDKIV	005652.00N 1041333.00E	VTK R-156.3 / D30.5	SJ R-126.3 / D27.7
IGNON	010847.00N 1041257.00E	VTK R-144.1 / D19.8	SJ R-101.8 / D22.2
IGOSI	005645.00N 1040644.00E	VTK R-169.1 / D28.6	SJ R-136.8 / D22.7
IKIRO	000849.00N 1044420.00E	VTK R-150.4 / D87.1	SJ R-140.4 / D83.4
ISGIL	004246.00N 1031257.00E	VTK R-229.1 / D64.1	SJ R-231.6 / D49
ISNOM	010629.00N 1035826.00E	VTK R-189 / D18.6	SJ R-133.6 / D9.9

Name	Coordinates	Radius/Distance from VTK	Radius/Distance from SJ
KANLA	034556.00N 1043606.00E	VTK R-13.8 / D144.5	SJ R-16.5 / D158.3
KARTO	011124.00N 1053343.00E	VTK R-98.3 / D93.5	SJ R-91.1 / D102.6
KEXAS	011019.00N 1044818.00E	VTK R-107.2 / D49.2	SJ R-93.0 / D57.2
KILOT	030217.00N 1044023.00E	VTK R-22.0 / D104.5	SJ R-24.4 / D119.0
KIRDA	000009.00N 1045934.00E	VTK R-145.4 / D102.7	SJ R-136.8 / D100.1
LAVAX	010950.00N 1042714.00E	VTK R-120.1 / D30.0	SJ R-95.5 / D36.2
LEDOX	011642.00N 1035651.00E	VTK R-208.6 / D9.4	SJ R-58.5 / D6.5
LELIB	012729.00N 1032450.00E	VTK R-274.0 / D36.6	SJ R-298.0 / D30.0
LETGO	011411.00N 1035548.00E	VTK R-207.3 / D12.1	SJ R-79.1 / D4.6
MABAL	032826.00N 1051236.00E	VTK R-30.1 / D142.1	SJ R-31.2 / D157.2
MASBO	020248.00N 1025251.00E	VTK R-299.0 / D78.3	SJ R-310.2 / D76.6
MIBEL	012351.00N 1020816.00E	VTK R-269.5 / D113.2	SJ R-275.8 / D103.7
MOLVO	012955.00N 1040227.00E	VTK R-12.8 / D5.1	SJ R-34.2 / D20
MOXIB	012933.00N 1040315.00E	VTK R-22.7 / D5	SJ R-36.7 / D20.1
MUMDU	010521.00N 1042714.00E	VTK R-126.9 / D32.4	SJ R-102.5 / D36.9
NYLON	013656.90N 1040623.80E	VTK R-23 / D13	SJ R-32.9 / D30.0
PALGA	011059.00N 1034759.00E	VTK R-223.8 / D19.3	SJ R-235.1 / D4.1
PAMSI	010459.00N 1034845.00E	VTK R-212.3 / D23.6	SJ R-197.2 / D8.7
PASPU	015915.00N 1040618.00E	VTK R-8.3 / D34.5	SJ R-18.3 / D48.1
PIBAP	023023.00N 1040618.00E	VTK R-4.4 / D65.3	SJ R-11.1 / D78.1
POSUB	012725.00N 1040748.00E	VTK R-69.0 / D6.9	SJ R-49.8 / D21.7
POVEB	011344.00N 1040130.00E	VTK R-179.2 / D11.1	SJ R-87.9 / D10.3
PU	012524.00N 1035600.00E	VTK R-275.2 / D5.4	SJ R-21.1 / D13.0
REMES	004342.00N 1035735.00E	VTK R-185.2 / D41.2	SJ R-167.9 / D30.2
REPOV	001623.00N 1040300.00E	VTK R-178.6 / D68.2	SJ R-168.3 / D57.9
RWY 02R DER	012122.00N 1040051.00E	VTK R-187.8 / D3.6	SJ R-50.3 / D12.5
RWY 02C DER	012145.00N 1035957.00E	VTK R-203.3 / D3.4	SJ R-45.8 / D12.1
RWY 02L DER	012305.00N 1035933.00E	VTK R-224.1 / D2.5	SJ R-40.6 / D12.8
RWY 20C DER	011942.00N 1035905.00E	VTK R-203 / D5.7	SJ R-50.8 / D10.1
RWY 20R DER	012047.00N 1035835.00E	VTK R-213.7 / D4.9	SJ R-44.8 / D10.4
RWY 20L DER	011919.00N 1035959.00E	VTK R-193.7 / D5.7	SJ R-55.8 / D10.6
SABKA	015051.00N 1031713.00E	VTK R-300.4 / D51.2	SJ R-317.7 / D50.7
SALRU	011701.00N 1040802.00E	VTK R-139.5 / D10.3	SJ R-77.8 / D17.2
SAMKO	010529.51N 1035254.86E	VTK R-203.5 / D21.1	SJ R-168 / D8
SANAT	010748.79N 1035929.76E	VTK R-186.1 / D17.1	SJ R-123.7 / D9.9
SEBVO	011259.00N 1044028.00E	VTK R-109.5 / D35.6	SJ R-90.5 / D43.6
SJ (SINJON)	011321.34N 1035115.22E	-	-
SURGA	003657.00S 1063119.00E	VTK R-129.1 / D193.3	SJ R-124.6 / D194.3
TAROS	004200.00N 1021612.00E	VTK R-247.9 / D139.4	SJ R-251.9 / D100.2
TEBUN	011455.00N 1031557.00E	VTK R-257.7 / D46.5	SJ R-272.5 / D35.4
TOMAN	012147.00N 1054717.00E	VTK R-91.7 / D106.2	SJ R-85.9 / D116.5
UGEBO	003813.00N 1052432.00E	VTK R-119.1 / D95.4	SJR-110.5 / D99.8
UKIBO	011758.00N 1035924.00E	VTK R-195.7 / D7.2	SJ R-60.6 / D9.4
UPTEL	005925.00N 1040730.00E	VTK R-166.3 / D26.1	SJ R-130.5 / D21.4
VAMPO	005833.00N 1032525.00E	VTK R-233.9 / D44.5	SJ R-240.4 / D29.8
VANBU	010643.00N 1042740.00E	VTK R-124.5 / D32	SJ R-100.3 / D37.1

Name	Coordinates	Radius/Distance from VTK	Radius/Distance from SJ
VASTI	004320.00N 1043406.00E	VTK R-141.6 / D52.8	SJ R-124.8 / D52.3
VEBMA	012030.00N 1045332.00E	VTK R-94.8 / D52.5	SJ R-83.5 / D57.8
VEXEL	005904.00N 1034254.00E	VTK R-215.7 / D31.7	SJ R-210.5 / D16.5
VIBOG	004310.00N 1034302.00E	VTK R-203.8 / D45.4	SJ R-195.3 / D31.2
VIGUD	011328.00N 1035730.00E	VTK R-198.6 / D69.7	SJ R-89 / D6.2
VIMAL	010942.00N 1042353.00E	VTK R-123.8 / D27.2	SJ R-96.4 / D22.9
VIRET	003940.00N 1043511.00E	VTK R-143 / D56.4	SJ R-127.3 / D55.3
VMR	022318.00N 1035218.00E	VTK R-351.2 / D58.8	SJ R-0.9 / D69.6
VOVOS	011123.00N 1032651.00E	VTK R-248.7 / D37.1	SJ R-265.4 / D24.5
VTK (TEKONG)	012455.36N 1040120.17E	-	-

21 SID / STAR PHRASEOLOGIES

21.1 SID / STAR phraseologies allow ATC and pilot to communicate and understand detailed clearance information that would otherwise require long and potentially complex transmissions. To eliminate safety risk due to a mismatch between ATC and pilot expectations when SID / STAR phraseologies are used, and what certain terms may mean, ICAO has published Amendment 7-A to Doc 4444, PANS- ATM to harmonise the core phraseologies that positively reinforce the lateral, vertical and speed requirements embedded in a SID or STAR that will continue to apply, unless explicitly cancelled or amended by the controller.

21.2 The core phraseologies are:

- i. CLIMB VIA SID TO (level)
- ii. DESCEND VIA STAR TO (level)

21.3 These require the aircraft to:

- i. Climb / descend to the cleared level in accordance with published level restrictions;
- ii. Follow the lateral profile of the procedure; and
- iii. Comply with published speed restrictions or ATC-issued speed control instructions as applicable.

21.4 Phraseologies for removal of speed or level restrictions are:

- i. CLIMB VIA SID TO (level), CANCEL SPEED RESTRICTION(S)
- ii. DESCEND VIA STAR TO (level), CANCEL LEVEL RESTRICTION(S) AT (point(s))

21.5 These phraseologies mean that:

- i. The lateral profile of the procedure continue to apply and
- ii. Speed or level restrictions which have not been referred to will continue to apply.

21.6 Phraseologies for variations to the lateral profile of the SID / STAR are:

- i. PROCEED DIRECT (waypoint), or
- ii. VECTORING

21.7 These phraseologies mean that speed and level restrictions associated with the bypassed waypoints are cancelled.

21.8 Phraseology to clear aircraft to return to SID / STAR is: REJOIN SID / STAR

21.9 This phraseology means that speed and level restrictions associated with the waypoint where the rejoin occurs, as well as those associated with all subsequent waypoints must be complied with.

21.10 The term 'VIA' will no longer be used when issuing lateral routing clearances.

22 LIGHT AIRCRAFT OPERATIONS

22.1 Light aircraft operations into and out of Singapore Changi Airport may be approved subject to the following conditions:

- a) Prior permission has been granted;
- b) Aircraft is suitably equipped;
- c) Pilot is appropriately rated;
- d) Subject to ATC.

22.2 Flight notification shall be given by filing a flight plan.

22.3 All such operations will be regulated in accordance with IFR procedures.

23 CHANGI FLOW MANAGEMENT PROCEDURES

23.1 INTRODUCTION

23.1.1 The objectives of the procedures are to improve the efficiency of Singapore's air traffic service by minimising radar vectoring as well as improving airspace capacity.

23.1.2 The procedures require the holding of Changi arrivals over established holding areas.

23.2 ENTRY AND EXIT GATES

23.2.1 'Entry gates' and 'Exit gates' are established to ensure segregation between arriving and departing aircraft operating at Singapore Changi Airport. These gates (waypoints) are incorporated in the RNAV SIDs/STARs which have been implemented to support the flow management procedures. The 'entry' and 'exit' gates are shown below:

<u>Entry Gate</u>	<u>Coordinates</u>
KEXAS	011019.00N 1044818.00E
PASPU	015915.00N 1040618.00E
REMES	004342.00N 1035735.00E
VAMPO	005833.00N 1032525.00E

23.3 ARRIVING AIRCRAFT TO SINGAPORE CHANGI AIRPORT

23.3.1 STANDARD INSTRUMENT ARRIVAL (STAR)

IFR flight should expect a Standard Instrument Arrival (STAR).

23.3.2 ENTRY GATE TIME

To regulate the flow of traffic into the Approach airspace, ATC will issue, when necessary, a time restriction at an entry gate associated with the inbound route of the flight into Singapore Changi Airport.

23.3.3 DESCENT PROFILE

Pilots shall plan their descent profile in accordance with the published STAR procedures.

23.3.4 SPEED CONTROL

Speed control restrictions are incorporated into the STARs to enhance predictability and planning of air traffic in the Approach airspace. Pilots shall adhere to the speed control restrictions published in the STAR procedures unless otherwise advised. ATC may issue further speed adjustment during the different phases of the flight if traffic situation warrants.

23.4 APPROACH AIRSPACE HOLDING PROCEDURES

23.4.1 ENTRY PROCEDURE

The entry into the holding patterns shall be in accordance with the three-sector entry procedure as prescribed in ICAO Doc 8168 - OPS/611 Edition 1993.

23.4.2 RATE OF TURN

All turns are to be made at a bank angle of 25° or at a rate of 3° per second, whichever requires the lesser bank.

23.4.3 DESCENT PROCEDURE

When instructed to join a holding pattern, pilots shall reach their assigned altitudes prior to arriving at the holding point. This will allow appropriate traffic sequencing and the reduction of step-descents in the holding pattern.

23.4.4 DETAILS OF APPROACH AIRSPACE HOLDING AREAS

<u>Holding Fix / ID / Co-ordinates</u>	<u>Inbound Track °M</u>	<u>Direction of Turn</u>	<u>MAX HLDG Speed (IAS)</u>	<u>Time (MIN)</u>	<u>MNM-MAX HLDG Level</u>	<u>Controlling Unit and Frequency</u>
<u>1</u>	<u>2</u>	<u>3</u>	<u>4</u>	<u>5</u>	<u>6</u>	<u>7</u>
NYLON 013657N 1040624E	203°	Left	220 knots	1	<u>FL140</u> 3,000ft	Singapore Approach 124.05MHz (PRI) 132.15MHz (SRY)
KEXAS 011019N 1044818E	268°	Left	220 knots	1	<u>FL160</u> 11,000ft	Singapore Approach 124.05MHz (PRI) 132.15MHz (SRY)
REMES 004342N 1035735E	348°	Left	220 knots	1	<u>FL140</u> 6,000ft	Singapore Approach 124.6MHz (PRI) 132.15MHz (SRY)

Holding Fix / ID / Co-ordinates	Inbound Track °M	Direction of Turn	MAX HLDG Speed (IAS)	Time (MIN)	MNM-MAX HLDG Level	Controlling Unit and Frequency
BOBAG 010230N 1032954E	082°	Right	220 knots	1	FL140 6,000ft	Singapore Approach 124.6MHz (PRI) 132.15MHz (SRY)
VAMPO 005833N 1032525E	149°	Right	220 knots	1	FL180 6,000ft	Singapore Approach 124.6MHz (PRI) 132.15MHz (SRY)

23.4.5 ALTERNATE HOLDING AREAS

In the event of inclement weather or capacity constraints rendering a specific holding area unusable, arrivals may be cleared to an alternate holding area for re-sequencing. To ensure smooth transition to alternate holding area, all arrivals bound for Singapore Changi Airport shall have their FMS programmed with all the four promulgated holding areas (paragraph 23.4.4).

23.5 EXPECTED TIME TO LEAVE HOLDING AREA

23.5.1 If arrival delay is processed by means of holding, pilots will be informed of the expected time to leave the respective holding area.

23.5.2 The expected time to leave is issued to serve as an early notification of the probable holding duration as well as for unforeseen circumstance such as radio failure (see ENR 1.6). Subsequently, a specified time to leave the holding area will be issued to pilots to resume the flight according to the assigned RNAV STARs.

23.6 DEPARTING AIRCRAFT FROM SINGAPORE CHANGI AIRPORT

23.6.1 DEPARTURE SPEED CONTROL

Departing aircraft shall not exceed IAS 230 knots below 4,000 feet AMSL or at the waypoints specified in the SID and not exceed IAS 250 knots below 10,000 feet AMSL. Pilots shall also comply with speed control restrictions according to published SIDs.

24 SIMULTANEOUS INDEPENDENT PARALLEL APPROACHES

24.1 INTRODUCTION

24.1.1 Simultaneous independent parallel approaches will be implemented daily between 0000UTC and 1500UTC to optimize runway utilization and enhance air traffic efficiency.

24.2 PROCEDURES FOR SIMULTANEOUS INDEPENDENT PARALLEL APPROACHES

24.2.1 To ensure safe operations between aircraft on parallel approaches, Normal Operating Zones (NOZs) are established for each extended runway centreline and a No Transgression Zone (NTZ) is established between the NOZs.

24.2.2 ATC will vector arriving flights into Singapore Changi Airport from the final waypoint of the respective STARs to the respective NOZs.

24.2.3 Within the NOZ, ATC shall provide a minimum vertical separation of 1,000ft or 3NM surveillance separation between pairs of aircraft until both aircraft are established on the ILS Localizer course.

24.2.4 ATC is not required to provide separation between aircraft on adjacent ILS Localizers and will monitor aircraft for deviation from the approach path.

24.2.5 Aircraft can expect to maintain altitude 2,500ft till Glide Path Interception for Runway 20R / 02L and 3,500ft till Glide Path Interception for Runway 20C / 02C. This is to ensure the necessary vertical separation prior to establishing on the respective ILS Localizer course.

24.2.6 Aircraft can expect the following radiotelephony phraseology to intercept the Localizer before clearing for ILS:

“TURN LEFT (RIGHT) HEADING (three digits) MAINTAIN (altitude) REPORT ESTABLISHED ON THE LOCALIZER RUNWAY (number) LEFT (CENTRE / RIGHT)”

followed by ...

“MAINTAIN (altitude), CLEARED FOR ILS APPROACH RUNWAY (number) LEFT (CENTRE/RIGHT)”

24.2.7 Aircraft can expect to maintain speed 180 knots at base turn or earlier till 8NM from touchdown.

24.3 BREAK-OUT MANOEUVRE

24.3.1 When an aircraft is observed to have not established on the appropriate Localizer course or deviated from its course towards the NTZ, ATC will instruct the aircraft to return immediately to the correct Localizer course with the following radiotelephony phraseology:

“YOU HAVE CROSSED THE LOCALIZER, TURN LEFT (or RIGHT) IMMEDIATELY AND RETURN TO THE LOCALIZER”

or

“TURN LEFT (or RIGHT) TO RETURN TO LOCALIZER COURSE”

24.3.2 When ATC observed aircraft to be penetrating or will penetrate the NTZ, ATC will instruct the aircraft on the adjacent Localizer course to alter course to avoid the deviating aircraft with the following radiotelephony phraseology:

“TRAFFIC ALERT, TURN LEFT (or RIGHT) IMMEDIATELY HEADING (degrees), CLIMB AND MAINTAIN (altitude)”

24.4 PILOT NOTIFICATION AND CONDITIONS FOR OPERATIONS

24.4.1 Simultaneous approaches to parallel runways operation will be broadcasted on ATIS during the active period.

24.4.2 Simultaneous approaches to the parallel runways will be suspended in the event of adverse weather or any other conditions that may affect the safe conduct of such approaches to the parallel runways.

WSSS AD 2.23 ADDITIONAL INFORMATION

1 BIRD CONCENTRATION IN THE VICINITY OF THE AIRPORT

1.1 A number of varieties of birds are found in Singapore throughout the year. The larger birds commonly found in Singapore Changi Airport include the following:

- cattle egrets (weighing approximately 400g each)
- intermediate egrets (weighing approximately 500g each)
- brahminy kites (weighing approximately 600g each)
- grey herons (weighing approximately 1500g each)
- white-bellied sea eagle (weighing approximately 2900g each)

1.2 There could be an increase in bird activities during the migratory months of September to March. During this period, migratory birds may use the airport as their feeding ground.

1.3 Various active dispersal devices generating light, sound or cracking effects are used for bird dispersal to mitigate wildlife hazards where necessary within Singapore Changi Airport (such as handheld laser device, long range acoustic device, scarecrow, stock-whip, pyrotechnic, etc.).

WSSS AD 2.24 CHARTS RELATED TO AN AERODROME

LOCATIONS OF RUNWAY 02L/20R, RUNWAY 02C/20C AND RUNWAY 02R/20L AT WSSS	AD-2-WSSS-ADC-1
AERODROME CHART - ICAO	AD-2-WSSS-ADC-2
AERODROME ADVISORY CHART - ICAO	AD-2-WSSS-ADC-3
AERODROME OBSTACLE CHART - ICAO TYPE A (OPERATING LIMITATIONS)	AD-2-WSSS-AOC-1
AERODROME OBSTACLE CHART - ICAO - TYPE A - RWY 02C/20C	AD-2-WSSS-AOC-2
AERODROME OBSTACLE CHART - ICAO - TYPE B	AD-2-WSSS-AOC-3
AERODROME OBSTACLE CHART ICAO - TYPE A - RWY 02R/20L	AD-2-WSSS-AOC-4
PRECISION APPROACH TERRAIN CHART - ICAO - RWY 02L	AD-2-WSSS-PATC-1
PRECISION APPROACH TERRAIN CHART - ICAO - RWY 20C	AD-2-WSSS-PATC-2
PRECISION APPROACH TERRAIN CHART - ICAO - RWY 02R	AD-2-WSSS-PATC-3
Precision Approach Terrain Chart - ICAO - RWY 20L	AD-2-WSSS-PATC-4
PRECISION APPROACH TERRAIN CHART - ICAO - RWY 02C	AD-2-WSSS-PATC-5
RNAV (GNSS) SID - RWY 02C - ANITO 7A	AD-2-WSSS-SID-1
RNAV(GNSS) SID - RWY 20C - ANITO 8B	AD-2-WSSS-SID-2
RNAV(GNSS) SID - RWY 02R - ANITO 1C	AD-2-WSSS-SID-3
RNAV (GNSS) SID - RWY 20L - ANITO 1D	AD-2-WSSS-SID-4
RNAV (GNSS) SID - RWY 02L - ANITO 7E	AD-2-WSSS-SID-5

RNAV (GNSS) SID - RWY 20R - ANITO 8F	AD-2-WSSS-SID-6
RNAV (GNSS) SID - RWY 02C - AROSO 3A	AD-2-WSSS-SID-7
RNAV (GNSS) SID - RWY 20C - AROSO 5B	AD-2-WSSS-SID-8
RNAV (GNSS) SID - RWY 02R - AROSO 1C	AD-2-WSSS-SID-9
RNAV (GNSS) SID - RWY 20L - AROSO 1D	AD-2-WSSS-SID-10
RNAV (GNSS) SID - RWY 02L - AROSO 3E	AD-2-WSSS-SID-11
RNAV (GNSS) SID - RWY 20R - AROSO 5F	AD-2-WSSS-SID-12
RNAV (GNSS) SID - RWY 02C - DODSO 1A	AD-2-WSSS-SID-13
RNAV(GNSS) SID - RWY 20C - DODSO 1B	AD-2-WSSS-SID-14
RNAV (GNSS) SID - RWY 02R - DODSO 1C	AD-2-WSSS-SID-15
RNAV (GNSS) SID - RWY 20L - DODSO 1D	AD-2-WSSS-SID-16
RNAV (GNSS) SID - RWY 02L - DODSO 1E	AD-2-WSSS-SID-17
RNAV (GNSS) SID - RWY 20R - DODSO 1F	AD-2-WSSS-SID-18
RNAV (GNSS) SID - RWY 02C - IDBUD 1A	AD-2-WSSS-SID-19
RNAV (GNSS) SID - RWY 20C - IDBUD 1B	AD-2-WSSS-SID-20
RNAV (GNSS) SID - RWY 02R - IDBUD 1C	AD-2-WSSS-SID-21
RNAV (GNSS) SID - RWY 20L - IDBUD 1D	AD-2-WSSS-SID-22
RNAV (GNSS) SID - RWY 02L - IDBUD 1E	AD-2-WSSS-SID-23
RNAV (GNSS) SID - RWY 20R - IDBUD 1F	AD-2-WSSS-SID-24
RNAV (GNSS) SID - RWY 02C - KIRDA 1A	AD-2-WSSS-SID-25
RNAV (GNSS) SID - RWY 20C - KIRDA 1B	AD-2-WSSS-SID-26
RNAV (GNSS) SID - RWY 02R - KIRDA 1C	AD-2-WSSS-SID-27
RNAV (GNSS) SID - RWY 20L - KIRDA 1D	AD-2-WSSS-SID-28
RNAV (GNSS) SID - RWY 02L - KIRDA 1E	AD-2-WSSS-SID-29
RNAV (GNSS) SID - RWY 20R - KIRDA 1F	AD-2-WSSS-SID-30
RNAV (GNSS) SID - RWY 02C - MASBO 3A	AD-2-WSSS-SID-31
RNAV (GNSS) SID - RWY 20C - MASBO 5B	AD-2-WSSS-SID-32
RNAV (GNSS) SID - RWY 02R - MASBO 1C	AD-2-WSSS-SID-33
RNAV (GNSS) SID - RWY 20L - MASBO 1D	AD-2-WSSS-SID-34
RNAV (GNSS) SID - RWY 02L - MASBO 3E	AD-2-WSSS-SID-35
RNAV (GNSS) SID - RWY 20R - MASBO 5F	AD-2-WSSS-SID-36
RNAV (GNSS) SID - RWY 02C - VMR 6A	AD-2-WSSS-SID-37
RNAV (GNSS) SID - RWY 20C - VMR 9B	AD-2-WSSS-SID-38
RNAV (GNSS) SID - RWY 02R - VMR 1C	AD-2-WSSS-SID-39
RNAV (GNSS) SID - RWY 20L - VMR 1D	AD-2-WSSS-SID-40
RNAV (GNSS) SID - RWY 02L - VMR 6E	AD-2-WSSS-SID-41
RNAV (GNSS) SID - RWY 02R - VMR 9F	AD-2-WSSS-SID-42
RNAV (GNSS) SID - RWY 02C - MIBEL 1A	AD-2-WSSS-SID-43
RNAV (GNSS) SID - RWY 20C - MIBEL 1B	AD-2-WSSS-SID-44
RNAV (GNSS) SID - RWY 02R - MIBEL 1C	AD-2-WSSS-SID-45
RNAV (GNSS) SID - RWY 20L - MIBEL 1D	AD-2-WSSS-SID-46
RNAV (GNSS) SID - RWY 02L - MIBEL 1E	AD-2-WSSS-SID-47
RNAV (GNSS) SID - RWY 20R - MIBEL 1F	AD-2-WSSS-SID-48
RNAV (GNSS) SID - RWY 02C - TAROS 1A	AD-2-WSSS-SID-49
RNAV (GNSS) SID - RWY 20C - TAROS 1B	AD-2-WSSS-SID-50
RNAV (GNSS) SID - RWY 02R - TAROS 1C	AD-2-WSSS-SID-51
RNAV (GNSS) SID - RWY 20L - TAROS 1D	AD-2-WSSS-SID-52
RNAV (GNSS) SID - RWY 02L - TAROS 1E	AD-2-WSSS-SID-53
RNAV (GNSS) SID - RWY 20R - TAROS 1F	AD-2-WSSS-SID-54
RNAV (GNSS) SID - RWY 02C - TOMAN 3A	AD-2-WSSS-SID-55
RNAV (GNSS) SID - RWY 20C - TOMAN 5B	AD-2-WSSS-SID-56
RNAV (GNSS) SID - RWY 02R - TOMAN 1C	AD-2-WSSS-SID-57
RNAV (GNSS) SID - RWY 20L - TOMAN 1D	AD-2-WSSS-SID-58
RNAV (GNSS) SID - RWY 02L - TOMAN 3E	AD-2-WSSS-SID-59
RNAV (GNSS) SID - RWY 20R - TOMAN 5F	AD-2-WSSS-SID-60
RNAV (GNSS) SID - RWY 20C - VOVOS 1B	AD-2-WSSS-SID-61
RNAV (GNSS) SID - RWY 20L - VOVOS 1D	AD-2-WSSS-SID-62
RNAV (GNSS) SID - RWY 20R - VOVOS 1F	AD-2-WSSS-SID-63
RNAV (GNSS) SID - RWY 02R/20L - CHA 1C / CHA 1D	AD-2-WSSS-SID-64
RNAV(GNSS) STAR - RWY 02L/02C/02R - ARAMA 1A	AD-2-WSSS-STAR-1
RNAV(GNSS) STAR - RWY 20R/20C/20L - ARAMA 1B	AD-2-WSSS-STAR-2
RNAV(GNSS) STAR - RWY 02L/02C/02R - ASUNA 2A	AD-2-WSSS-STAR-3
RNAV(GNSS) STAR - RWY 20R/20C/20L - ASUNA 2B	AD-2-WSSS-STAR-4
RNAV(GNSS) STAR - RWY 02L/02C/02R - ELALO 1A	AD-2-WSSS-STAR-5

RNAV(GNSS) STAR - RWY 20R/20C/20L - ELALO 1B	AD-2-WSSS-STAR-6
RNAV(GNSS) STAR - RWY 02L/02C/02R - KARTO 2A	AD-2-WSSS-STAR-7
RNAV(GNSS) STAR - RWY 20R/20C/20L - KARTO 2B	AD-2-WSSS-STAR-8
RNAV(GNSS) STAR - RWY 02L/02C/02R - LEBAR 2A	AD-2-WSSS-STAR-9
RNAV(GNSS) STAR - RWY 20R/20C/20L - LEBAR 3B	AD-2-WSSS-STAR-10
RNAV(GNSS) STAR - RWY 20R/20C/20L - LELIB 3B	AD-2-WSSS-STAR-11
RNAV(GNSS) STAR - RWY 02L/02C/02R - MABAL 2A	AD-2-WSSS-STAR-12
RNAV(GNSS) STAR - RWY 20R/20C/20L - MABAL 2B	AD-2-WSSS-STAR-13
RNAV(GNSS) STAR - RWY 02L/02C/02R - REPOV 2A	AD-2-WSSS-STAR-14
RNAV(GNSS) STAR - RWY 20R/20C/20L - REPOV 2B	AD-2-WSSS-STAR-15
RNAV(GNSS) STAR - RWY 02L/02C/02R - TEBUN 1A	AD-2-WSSS-STAR-16
RNAV(GNSS) STAR - RWY 20R/20C/20L - TEBUN 1B	AD-2-WSSS-STAR-17
RNAV(GNSS) STAR - RWY 02L/02C/02R - UGEB0 1A	AD-2-WSSS-STAR-18
RNAV(GNSS) STAR - RWY 20R/20C/20L - UGEB0 1B	AD-2-WSSS-STAR-19
Instrument Approach Chart - ICAO - RWY 02L - ICW ILS/DME	AD-2-WSSS-IAC-1
Instrument Approach Chart - ICAO - RWY 02C - ICE ILS/DME	AD-2-WSSS-IAC-2
Instrument Approach Chart - ICAO - RWY 02R - ICX ILS/DME	AD-2-WSSS-IAC-3
Instrument Approach Chart - ICAO - RWY 20R - ICH ILS/DME	AD-2-WSSS-IAC-5
Instrument Approach Chart - ICAO - RWY 20C - ICC ILS/DME	AD-2-WSSS-IAC-6
Instrument Approach Chart - ICAO - RWY 20C - VTK DVOR/DME	AD-2-WSSS-IAC-7
Instrument Approach Chart - ICAO - RWY 02L - RNP	AD-2-WSSS-IAC-9
Instrument Approach Chart - ICAO - RWY 02C - RNP	AD-2-WSSS-IAC-10
Instrument Approach Chart - ICAO - RWY 20R - RNP	AD-2-WSSS-IAC-11
Instrument Approach Chart - ICAO - RWY 20C - RNP	AD-2-WSSS-IAC-12
Instrument Approach Chart - ICAO - RWY 02R - RNP	AD-2-WSSS-IAC-13
Instrument Approach Chart - ICAO - RWY 20L - RNP	AD-2-WSSS-IAC-14
Visual Approach Chart - ICAO	AD-2-WSSS-VAC-1

WSSS AD 2.25 VISUAL SEGMENT SURFACE (VSS) PENETRATION

NIL (not applicable).

Intentionally Left Blank

LOCATIONS OF RUNWAY 02L/20R, RUNWAY 02C/20C AND RUNWAY 02R/20L AT WSSS

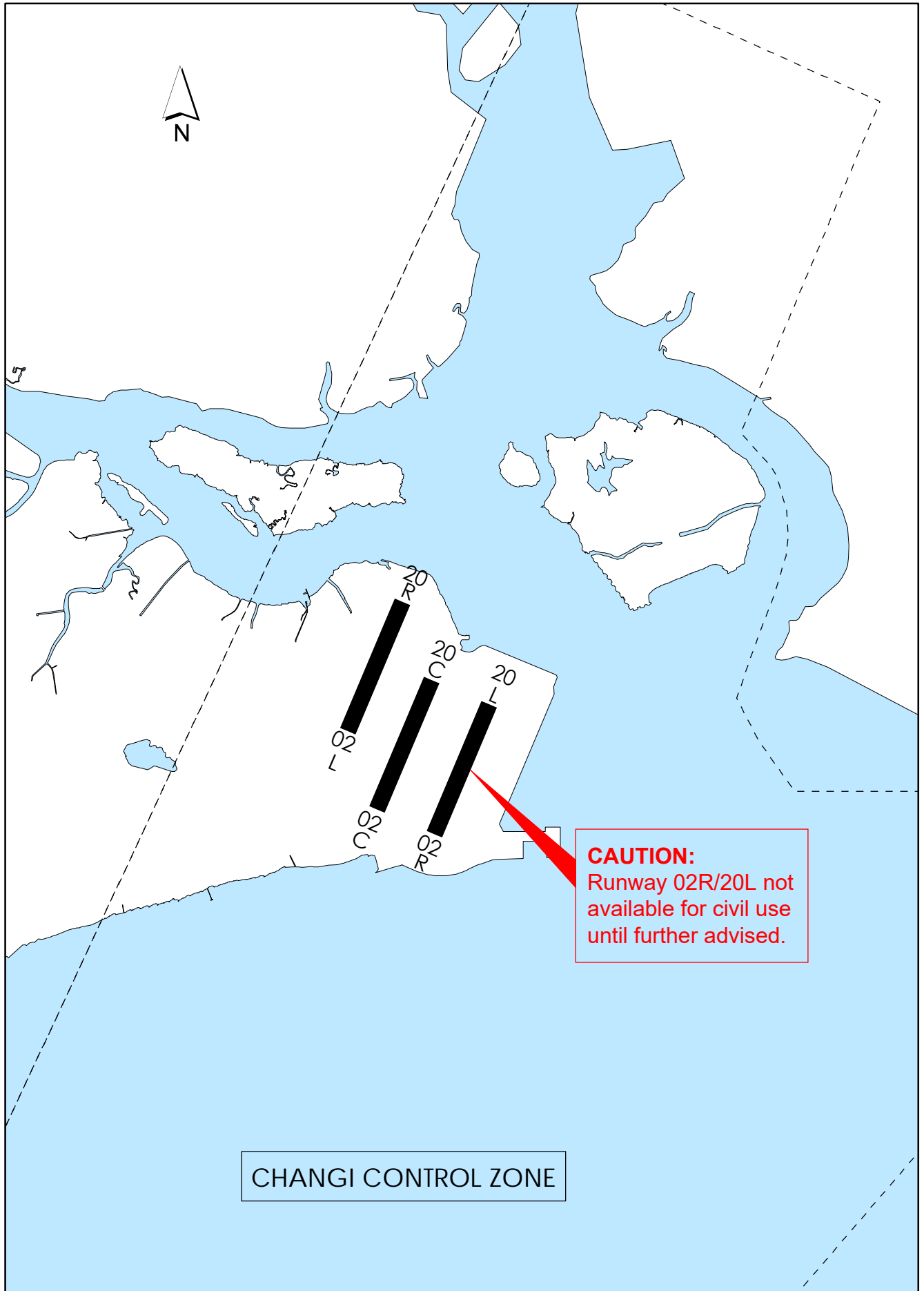

Intentionally Left Blank

AERODROME CHART - ICAO

01 21° 33'N
103° 59' 22'E

AERODROME ELEVATION 6.66m

TWR 118.6 / 118.25 / 131.4
GND 124.3 / 121.85 / 121.725 / 127.275
DELIVERY 121.65 / 119.6

RAMP TWR 122.55 (GMC 4 EAST)
GND 125.65 (GMC 4 WEST)

SINGAPORE/SINGAPORE CHANGI

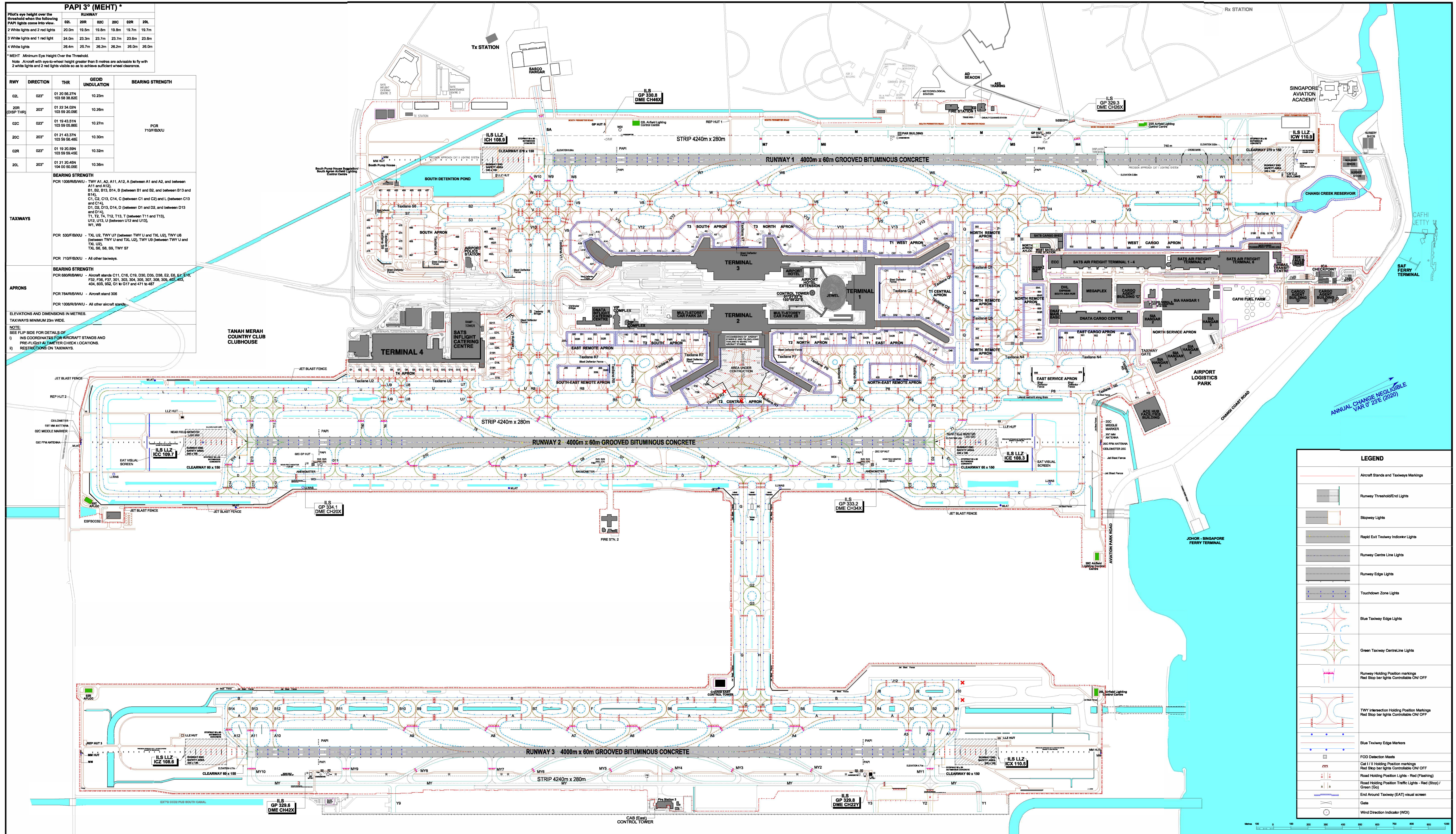

PAPI 3° (MEHT) *

Pilot's eye height over the threshold when the following PAPI lights are visible:

Runway	02L	20R	02C	20C	03R	20L
2 White lights and 2 red lights	20.0m	19.5m	19.8m	19.8m	19.7m	19.7m
3 White lights and 1 red light	24.0m	23.3m	23.7m	23.7m	23.6m	23.6m
4 White lights	26.4m	25.7m	26.2m	26.2m	26.0m	26.0m

* MEHT - Minimum Eye Height Over the Threshold.
Note: Aircraft with eye-to-threshold height greater than 8 metres are advised to fly with 2 white lights and 2 red lights visible so as to achieve sufficient wheel clearance.

Rwy	Direction	THR	GEOD UNDULATION	BEARING STRENGTH
02L	023°	01 20 58.27N 102 59 38.58E	10.23m	
20R	203°	01 22 34.02N 103 59 20.06E	10.26m	
02C	023°	01 19 43.21N 102 59 05.88E	10.27m	PCR 710°/800U
20C	203°	01 21 43.37N 102 59 06.45E	10.30m	
03R	023°	01 19 30.59N 103 59 58.45E	10.32m	
20L	203°	01 21 20.45N 104 00 50.00E	10.36m	

BEARING STRENGTH
PCR 1006R/BWU - TWY A1, A2, A11, A12, A (between A1 and A2, and between A11 and A12), B1, B2, B13, B14, B (between B1 and B2, and between B13 and B14), C1, C2, C13, C14, C (between C1 and C2), and L (between C13 and C14), D1, D2, D13, D14, D (between D1 and D2, and between D13 and D14), T1, T2, T4, T12, T13, T (between T1 and T13), U12, U13, U (between U12 and U13), W1, W9

TAXIWAYS
PCR 530F/B0U - TXL U2, TWY U7 (between TWY U and TXL U2), TWY UB (between TWY U and TXL U2), TWY UB (between TWY U and TXL U2), TXL UB, SB, S9, TWY S7

APRONS
PCR 784R/BWU - Aircraft stand 306
PCR 1006R/BWU - All other aircraft stands

ELEVATIONS AND DIMENSIONS IN METRES.
TAXIWAYS MINIMUM 23m WIDE.

NOTE:
1) SEE FLIP SIDE FOR DETAILS OF THE COORDINATES FOR AIRCRAFT STANDS AND PRE-FLIGHT CHECKER LOCATIONS.
2) RESTRICTIONS ON TAXIWAYS.

LEGEND

- Aircraft Stands and Taxiway Markings
- Runway Threshold/End Lights
- Stopway Lights
- Rapid Exit Taxiway Indicator Lights
- Runway Centre Line Lights
- Runway Edge Lights
- Touchdown Zone Lights
- Blue Taxiway Edge Lights
- Green Taxiway Centre Line Lights
- Runway Holding Position markings
Red Stop bar lights Controllable ON/OFF
- TWY Intersection Holding Position Markings
Red Stop bar lights Controllable ON/OFF
- Blue Taxiway Edge Markers
- FOD Detection Mats
- Call / H Holding Position markings
Red Stop bar lights Controllable ON/OFF
- Road Holding Position Lights - Red (Flashing)
Green (On)
- Road Holding Position Traffic Lights - Red (Stop) / Green (Go)
- End Around Taxiway (EAT) Visual Screen
- Gate
- Wind Direction Indicator (WDI)

INS COORDINATES FOR AIRCRAFT STANDS AND PRE-FLIGHT ALTIMETER CHECK LOCATIONS

LOCATION	STAND NR	NORTH LAT	EAST LONG	ELEVATION	
T3 SOUTH APRON	A1	01 21 21.52	103 59 06.25	4.75m (15.58ft)	
	A2	01 21 21.75	103 59 04.00	4.65m (15.26ft)	
	A3	01 21 19.86	103 59 02.79	4.69m (15.29ft)	
	A4	01 21 17.61	103 59 02.54	4.79m (15.72ft)	
	A5	01 21 15.50	103 59 03.62	4.86m (15.94ft)	
	A9	01 21 12.56	103 59 03.65	5.02m (16.47ft)	
	A10	01 21 10.34	103 59 02.40	5.04m (16.54ft)	
	A11	01 21 07.93	103 59 01.41	5.25m (17.22ft)	
	A12	01 21 05.76	103 59 00.49	5.38m (17.65ft)	
	A13	01 21 03.59	103 58 59.58	5.49m (17.98ft)	
	A14	01 21 01.66	103 58 57.59	5.57m (18.27ft)	
	A15	01 21 00.77	103 58 55.41	5.49m (17.91ft)	
	A16	01 20 59.27	103 58 54.20	5.31m (16.08ft)	
	A17	01 20 57.25	103 58 54.06	5.23m (17.16ft)	
	A18	01 20 55.67	103 58 55.25	5.37m (17.62ft)	
	A19	01 20 55.26	103 58 57.13	5.40m (17.72ft)	
	A20	01 20 56.09	103 58 58.83	5.45m (17.88ft)	
	A21	01 20 57.10	103 59 00.80	5.49m (18.01ft)	
	T3 NORTH APRON	B1	01 21 28.86	103 59 08.37	4.82m (15.81ft)
		B2	01 21 28.18	103 59 06.82	4.88m (15.35ft)
B3		01 21 30.33	103 59 07.30	4.65m (15.26ft)	
B4		01 21 30.63	103 59 08.80	4.75m (15.58ft)	
B5		01 21 32.98	103 59 10.89	4.80m (15.75ft)	
B6		01 21 35.15	103 59 13.16	4.96m (16.27ft)	
B7		01 21 37.65	103 59 13.93	4.97m (16.31ft)	
B8		01 21 39.94	103 59 15.20	5.13m (16.83ft)	
B9		01 21 42.19	103 59 16.16	5.13m (16.83ft)	
B10		01 21 44.47	103 59 17.12	5.15m (16.90ft)	
T1 WEST APRON	C1	01 21 46.75	103 59 18.08	5.09m (16.70ft)	
	C20	01 21 48.83	103 59 19.23	5.09m (16.67ft)	
	C22	01 21 51.00	103 59 20.13	5.15m (16.90ft)	
	C23	01 21 53.56	103 59 20.77	5.08m (16.67ft)	
	C24	01 21 56.54	103 59 20.97	4.89m (16.04ft)	
	C25	01 21 59.12	103 59 20.59	4.89m (16.04ft)	
	C26	01 22 01.48	103 59 20.76	5.01m (16.44ft)	
	C11	01 21 47.42	103 59 23.82	5.09m (16.70ft)	
	C13	01 21 48.63	103 59 24.92	5.03m (16.50ft)	
	C15	01 21 51.89	103 59 25.70	5.06m (16.60ft)	
C16	01 21 53.47	103 59 26.62	4.89m (16.04ft)		
C17	01 21 55.50	103 59 26.20	5.01m (16.44ft)		
C17R	01 21 54.75	103 59 26.22	4.99m (16.27ft)		
C17R	01 21 56.01	103 59 25.86	5.12m (16.80ft)		
C18	01 21 57.86	103 59 25.75	4.99m (16.37ft)		
C19	01 21 59.79	103 59 25.63	4.95m (16.24ft)		
T1 CENTRAL APRON	D30	01 21 44.54	103 59 30.14	5.09m (16.67ft)	
	D32	01 21 46.75	103 59 31.06	5.09m (16.67ft)	
	D34	01 21 49.03	103 59 32.04	5.07m (16.63ft)	
	D35	01 21 50.87	103 59 32.82	5.02m (16.47ft)	
	D36	01 21 51.98	103 59 34.52	5.06m (16.60ft)	
	D37	01 21 53.37	103 59 36.26	4.97m (16.31ft)	
	D38	01 21 54.58	103 59 37.77	4.99m (16.37ft)	
	D40	01 21 38.13	103 59 32.89	5.11m (16.77ft)	
	D40L	01 21 37.36	103 59 32.83	5.09m (16.70ft)	
	D40R	01 21 38.77	103 59 32.84	5.13m (16.83ft)	
D41	01 21 40.30	103 59 33.81	5.07m (16.63ft)		
D42	01 21 42.77	103 59 34.58	5.15m (16.89ft)		
D42L	01 21 42.00	103 59 34.47	5.12m (16.79ft)		
D42R	01 21 43.45	103 59 34.44	5.21m (17.08ft)		
D44	01 21 44.97	103 59 35.44	5.14m (16.88ft)		
D46	01 21 47.40	103 59 36.72	5.08m (16.67ft)		
D47	01 21 49.19	103 59 38.89	4.93m (16.17ft)		
D48	01 21 50.60	103 59 40.77	4.97m (16.31ft)		
D49	01 21 52.23	103 59 42.35	4.98m (16.34ft)		
T2 NORTH APRON	E8	01 21 27.99	103 59 38.45	4.68m (15.35ft)	
	E10	01 21 24.12	103 59 32.64	4.75m (15.58ft)	
	E11	01 21 25.57	103 59 34.37	4.78m (15.68ft)	
	E12	01 21 27.20	103 59 36.42	4.75m (15.58ft)	
	E20	01 21 24.36	103 59 27.08	5.04m (16.54ft)	
	E22	01 21 26.64	103 59 28.04	5.07m (16.63ft)	
	E24	01 21 29.01	103 59 29.06	5.09m (16.70ft)	
	E24L	01 21 28.32	103 59 28.77	5.10m (16.73ft)	
	E24R	01 21 29.53	103 59 29.28	5.08m (16.67ft)	
	E26	01 21 31.19	103 59 29.96	5.08m (16.67ft)	
E27	01 21 33.56	103 59 30.96	5.07m (16.62ft)		
E27L	01 21 32.79	103 59 30.86	5.03m (16.48ft)		
E27R	01 21 34.20	103 59 30.91	5.12m (16.80ft)		
E28	01 21 35.74	103 59 31.89	5.08m (16.67ft)		

INS COORDINATES FOR AIRCRAFT STANDS AND PRE-FLIGHT ALTIMETER CHECK LOCATIONS

LOCATION	STAND NR	NORTH LAT	EAST LONG	ELEVATION
T2 CENTRAL APRON	E2	01 21 19.28	103 59 27.30	4.90m (16.08ft)
	E3	01 21 18.44	103 59 29.27	4.82m (15.81ft)
	E4	01 21 18.10	103 59 31.70	4.80m (15.75ft)
	E5	01 21 19.56	103 59 33.72	4.90m (16.08ft)
	E6	01 21 21.22	103 59 35.93	4.84m (15.88ft)
	E7	01 21 22.48	103 59 37.46	4.73m (15.52ft)
	F31	01 21 13.87	103 59 25.30	4.91m (16.11ft)
	F32	01 21 13.03	103 59 27.26	4.85m (15.91ft)
	F33	01 21 11.30	103 59 28.54	4.91m (16.11ft)
	F34	01 21 08.98	103 59 28.96	4.92m (16.14ft)
T2 SOUTH APRON	F37	01 20 59.83	103 59 27.87	4.75m (15.58ft)
	F40	01 21 05.82	103 59 25.34	4.85m (15.91ft)
	F41	01 21 03.19	103 59 25.58	4.82m (15.81ft)
	F42	01 21 00.61	103 59 25.96	4.72m (15.49ft)
	F50	01 21 10.69	103 59 21.32	5.03m (16.50ft)
	F52	01 21 09.51	103 59 20.40	5.11m (16.77ft)
	F52L	01 21 07.82	103 59 20.11	5.16m (16.93ft)
	F52R	01 21 09.04	103 59 20.62	5.08m (16.67ft)
	F54	01 21 06.14	103 59 19.40	5.22m (17.13ft)
	F56	01 21 03.96	103 59 18.48	5.30m (17.39ft)
EAST REMOTE APRON	F56L	01 21 03.27	103 59 18.18	5.42m (17.78ft)
	F56R	01 21 04.49	103 59 18.70	5.34m (17.52ft)
	F58	01 21 01.58	103 59 17.47	5.49m (18.01ft)
	F59	01 20 59.41	103 59 16.55	5.64m (18.50ft)
	F59L	01 20 58.72	103 59 16.26	5.67m (18.60ft)
	F59R	01 20 59.93	103 59 16.78	5.60m (18.37ft)
	F60	01 20 56.91	103 59 15.50	5.77m (18.93ft)
	200	01 20 47.83	103 59 11.67	6.23m (20.44ft)
	200L	01 20 46.91	103 59 11.92	6.29m (20.64ft)
	200R	01 20 48.35	103 59 11.89	6.18m (20.28ft)
SOUTH-EAST REMOTE APRON	201	01 20 49.99	103 59 12.62	5.96m (19.55ft)
	202	01 20 52.34	103 59 13.57	5.94m (19.49ft)
	202L	01 20 51.65	103 59 13.28	5.76m (18.90ft)
	202R	01 20 52.87	103 59 13.79	5.73m (18.80ft)
	203	01 20 54.52	103 59 14.47	5.92m (19.42ft)
	205	01 20 43.91	103 59 17.06	4.77m (15.65ft)
	206	01 20 46.08	103 59 17.98	4.76m (15.62ft)
	207	01 20 48.21	103 59 19.01	4.74m (15.56ft)
	208	01 20 50.68	103 59 20.05	4.75m (15.58ft)
	208L	01 20 50.01	103 59 19.76	4.74m (15.55ft)
NORTH REMOTE APRON	208R	01 20 51.25	103 59 20.29	4.73m (15.42ft)
	300	01 22 06.95	103 59 22.67	4.53m (14.86ft)
	301	01 22 06.41	103 59 24.69	4.93m (16.17ft)
	302	01 22 05.21	103 59 26.75	4.97m (16.31ft)
	303	01 22 03.56	103 59 31.40	5.32m (17.45ft)
	304	01 22 02.84	103 59 33.06	5.35m (17.55ft)
	305	01 22 02.14	103 59 34.71	5.30m (17.39ft)
	306	01 22 01.41	103 59 36.42	5.16m (16.93ft)
	307	01 21 59.39	103 59 40.36	5.16m (16.93ft)
	308	01 21 58.96	103 59 41.35	5.10m (16.73ft)
T4 APRON	309	01 21 58.52	103 59 43.17	5.06m (16.60ft)
	310	01 21 57.42	103 59 44.96	4.74m (15.55ft)
	951	01 22 09.35	103 59 45.23	5.15m (16.90ft)
	951L	01 22 08.91	103 59 44.27	5.00m (16.40ft)
	951R	01 22 08.35	103 59 45.58	5.00m (16.40ft)
	952	01 22 09.94	103 59 42.65	4.89m (16.04ft)
	953	01 22 11.22	103 59 40.85	4.86m (15.94ft)
	953L	01 22 10.78	103 59 39.89	4.83m (15.85ft)
	953R	01 22 10.41	103 59 41.28	4.87m (15.98ft)
	954	01 22 12.46	103 59 37.95	4.84m (15.88ft)
NORTH-EAST REMOTE APRON	954L	01 22 12.02	103 59 36.99	4.70m (15.42ft)
	954R	01 22 11.65	103 59 38.38	4.74m (15.55ft)
	400	01 21 38.71	103 59 40.14	4.31m (14.14ft)
	401	01 21 40.98	103 59 41.10	4.31m (14.14ft)
	402	01 21 42.85	103 59 41.89	4.30m (14.11ft)
	403	01 21 44.37	103 59 42.53	4.29m (14.07ft)
	404	01 21 45.45	103 59 42.98	4.20m (13.78ft)

INS COORDINATES FOR AIRCRAFT STANDS AND PRE-FLIGHT ALTIMETER CHECK LOCATIONS

LOCATION	STAND NR	NORTH LAT	EAST LONG	ELEVATION
WEST CARGO APRON	502	01 22 22.23	103 59 31.62	4.35m (14.27ft)
	503	01 22 24.98	103 59 32.78	4.29m (14.07ft)
	504	01 22 27.26	103 59 33.74	4.29m (14.07ft)
	505	01 22 29.54	103 59 34.70	4.32m (14.17ft)
	506	01 22 31.81	103 59 35.66	4.38m (14.37ft)
	507	01 22 34.11	103 59 36.64	4.36m (14.30ft)
	508	01 22 36.41	103 59 37.61	4.29m (14.07ft)
	509	01 22 39.12	103 59 38.76	4.09m (13.42ft)
	510	01 22 41.37	103 59 40.18	4.19m (13.75ft)
	511	01 22 43.54	103 59 41.09	4.22m (13.85ft)
	512	01 22 45.71	103 59 42.01	4.24m (13.91ft)
	513	01 22 47.89	103 59 42.92	4.26m (13.98ft)
	514	01 22 50.19	103 59 43.54	4.36m (14.30ft)
	515	01 22 52.90	103 59 43.20	4.09m (13.43ft)
	516	01 22 55.39	103 59 43.97	4.04m (13.26ft)
	516R	01 22 56.26	103 59 43.80	3.96m (12.98ft)
	517	01 22 58.02	103 59 43.25	3.95m (12.97ft)
	517L	01 22 58.83	103 59 44.99	3.98m (13.05ft)
	517R	01 22 57.55	103 59 44.35	3.96m (12.98ft)
	EAST CARGO APRON	600	01 22 14.12	103 59 48.10
600L		01 22 13.28	103 59 48.27	4.22m (13.83ft)
600R		01 22 14.58	103 59 48.81	4.15m (13.60ft)
601		01 22 16.52	103 59 49.27	4.27m (14.01ft)
602		01 22 18.80	103 59 50.23	4.30m (14.11ft)
603		01 22 21.15	103 59 51.02	4.28m (14.07ft)
604				

AERODROME ADVISORY CHART

Advisory 4
Pilots taxiing on TWY V are to maintain a lookout to ensure sufficient wing tip clearance

Advisory 1
Pilots taxiing on TXL R4 are to maintain a lookout to ensure sufficient wing tip clearance

Advisory 2
Pilots taxiing on TWY T are to maintain a lookout to ensure sufficient wing tip clearance

Advisory 3
Pilots taxiing on TWY N or P to holding point T1 or T2 via TWY T are to pay extra attention to ground signages and lightings to prevent the mistaken identification of TWY T as RWY 20C

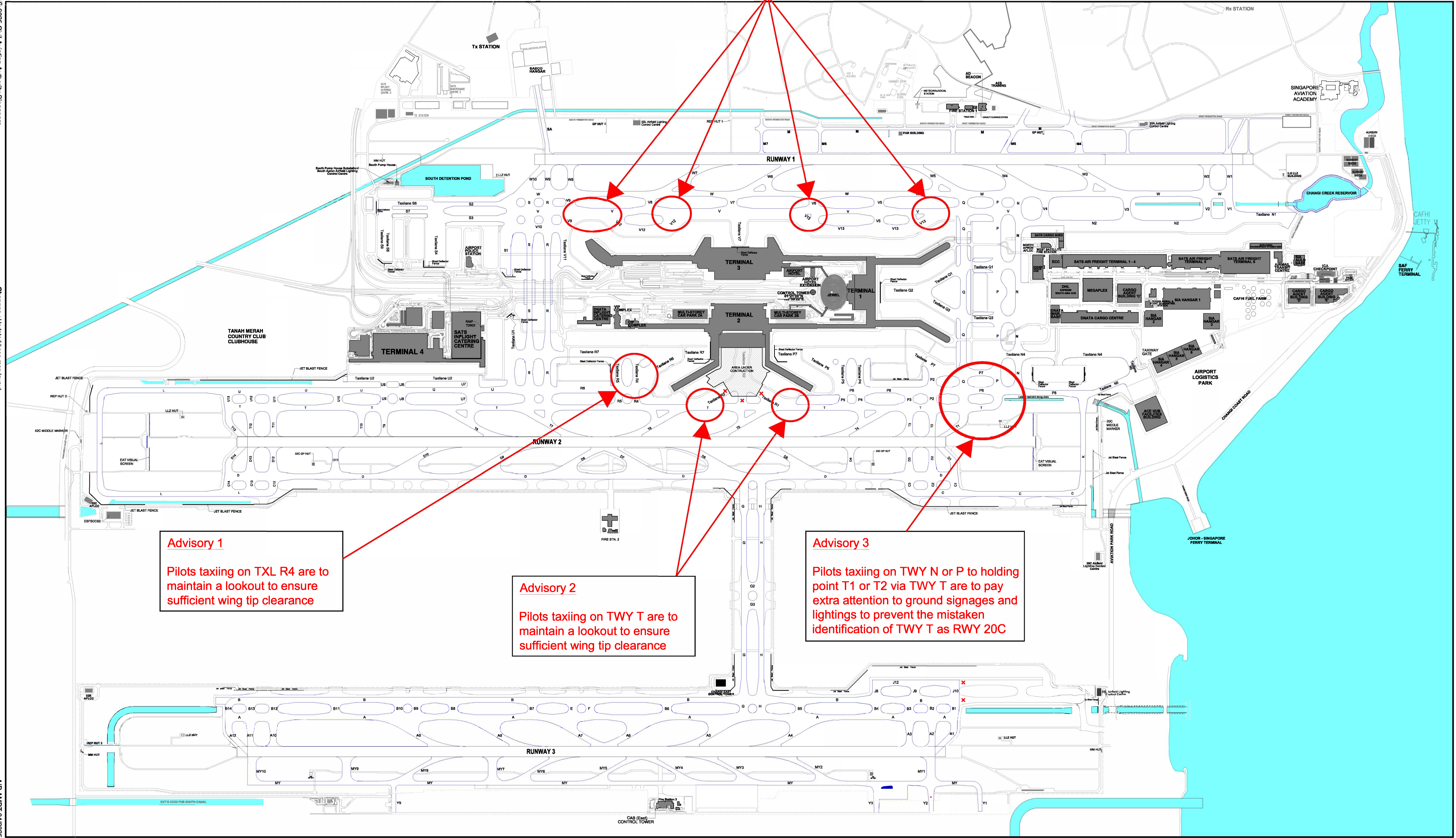

Intentionally Left Blank

DIMENSIONS AND ELEVATIONS IN METRES

**AERODROME OBSTACLE CHART - ICAO
TYPE A (OPERATING LIMITATIONS)**

SINGAPORE/Singapore Changi

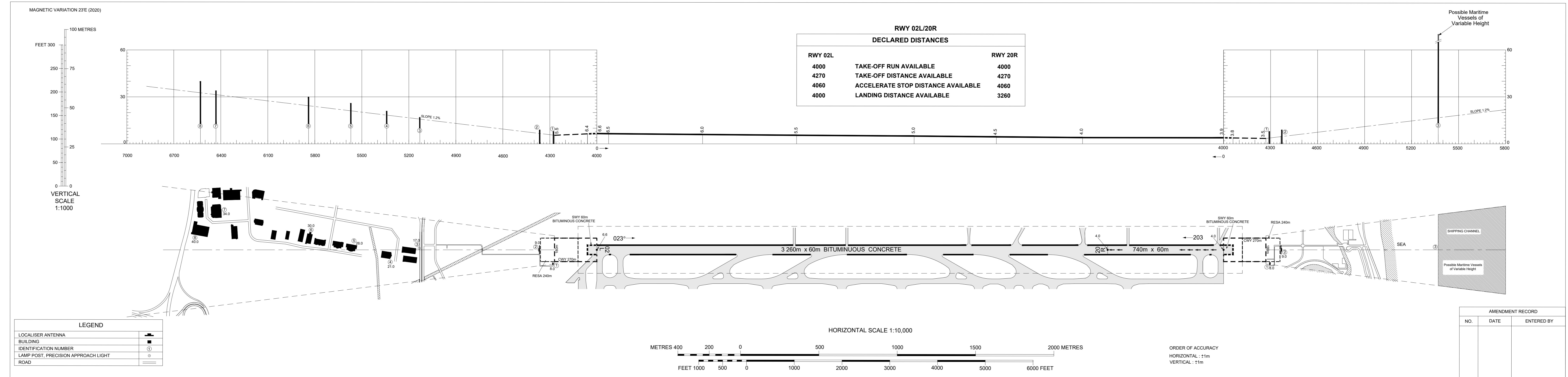

Intentionally Left Blank

DIMENSIONS AND ELEVATIONS IN METRES

AERODROME OBSTACLE CHART - ICAO TYPE A (OPERATING LIMITATIONS)

SINGAPORE/Singapore Changi

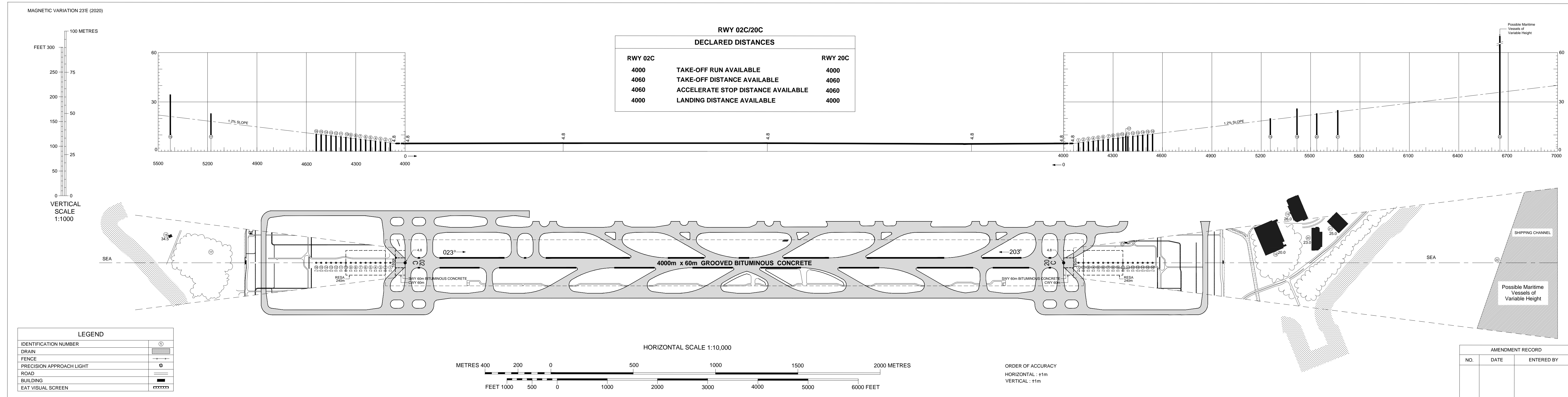

Intentionally Left Blank

AERODROME OBSTACLE CHART - ICAO TYPE B

SINGAPORE / Singapore Changi

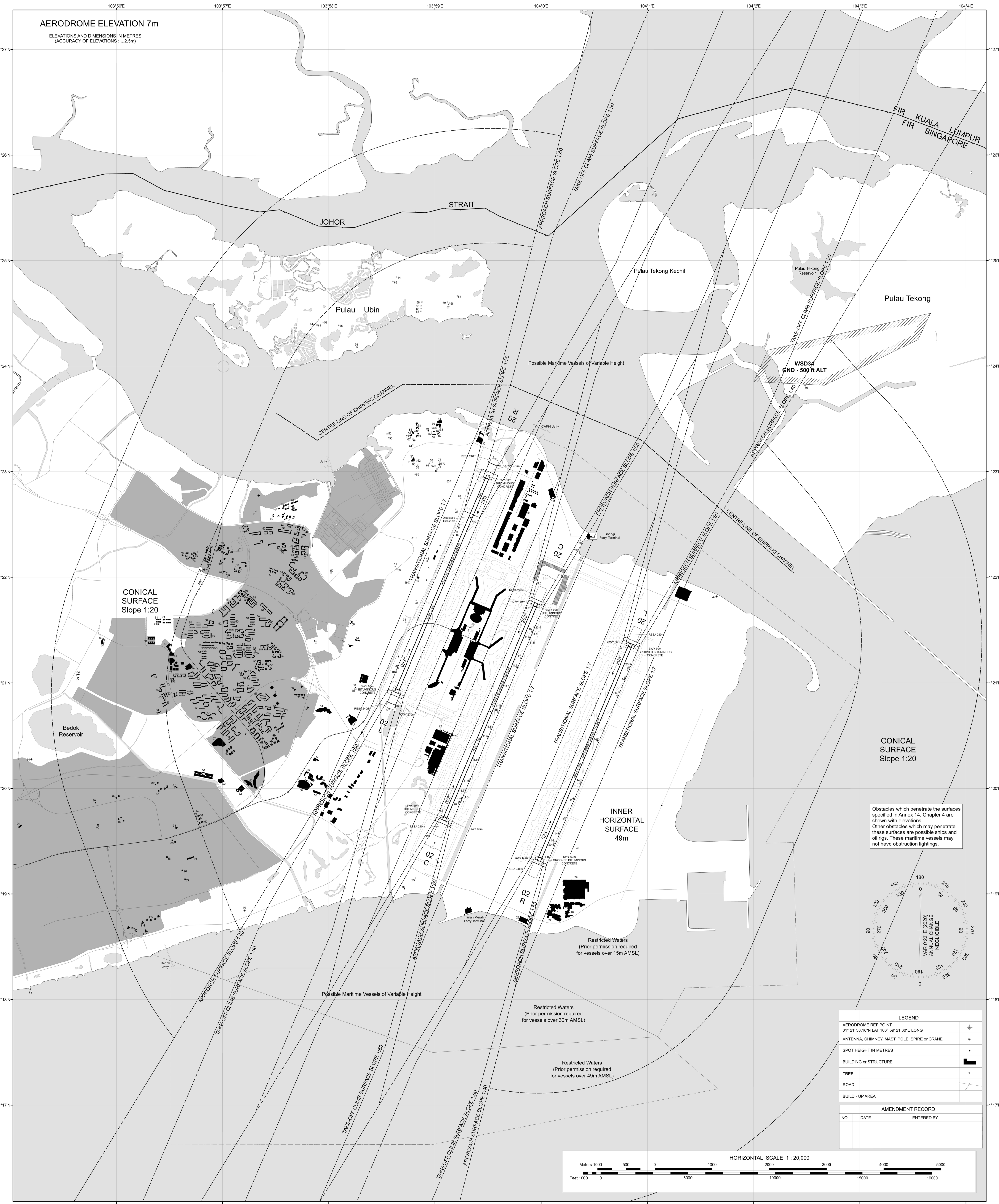

Intentionally Left Blank

DIMENSIONS AND ELEVATIONS IN METRES

**AERODROME OBSTACLE CHART - ICAO
TYPE A (OPERATING LIMITATIONS)**

SINGAPORE/Singapore Changi

MAGNETIC VARIATION 0°23'E (2020)

RWY 02R/20L

DECLARED DISTANCES

RWY 02R		RWY 20L
4000	TAKE-OFF RUN AVAILABLE	4000
4060	TAKE-OFF DISTANCE AVAILABLE	4060
4060	ACCELERATE STOP DISTANCE AVAILABLE	4060
4000	LANDING DISTANCE AVAILABLE	4000

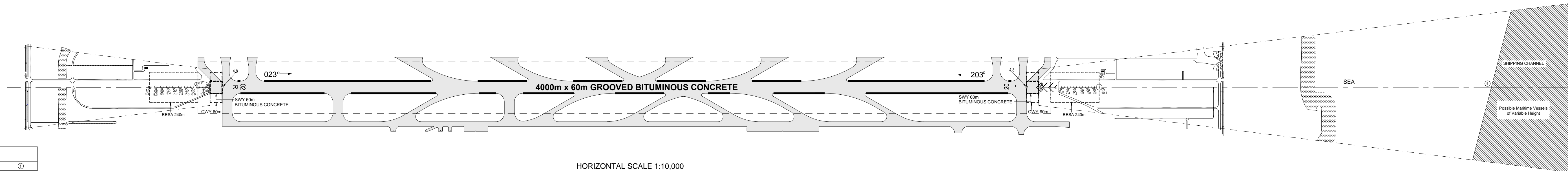
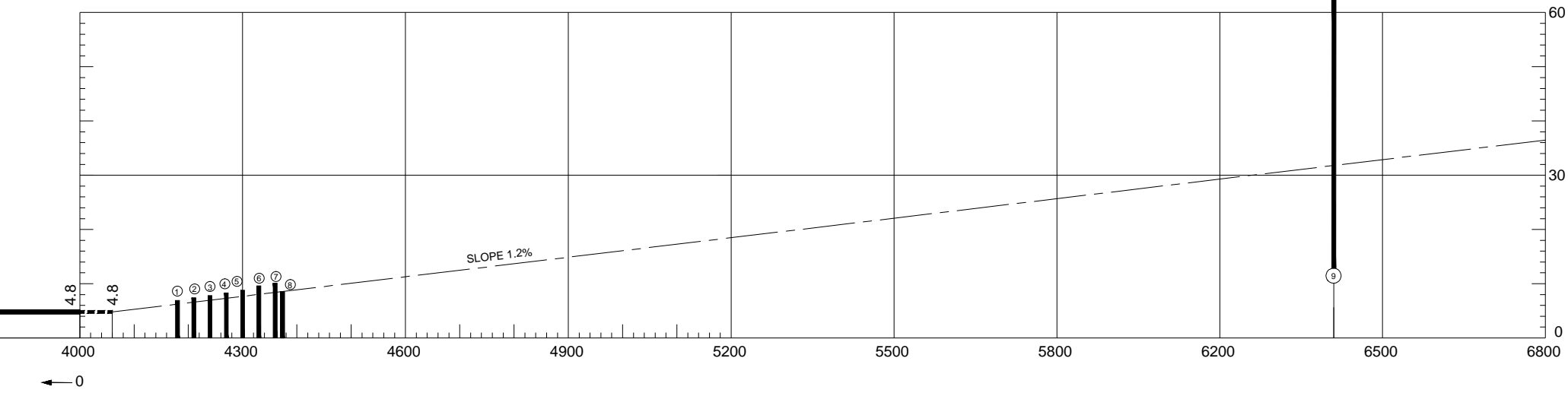
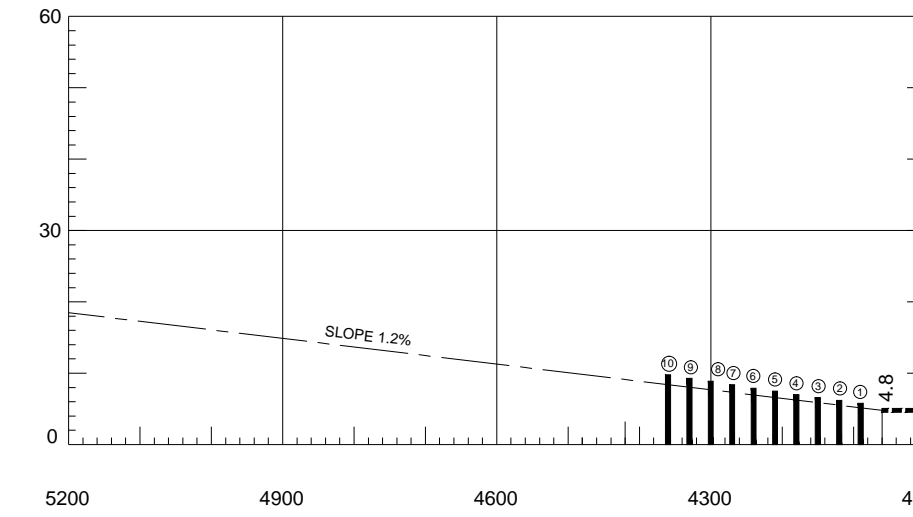
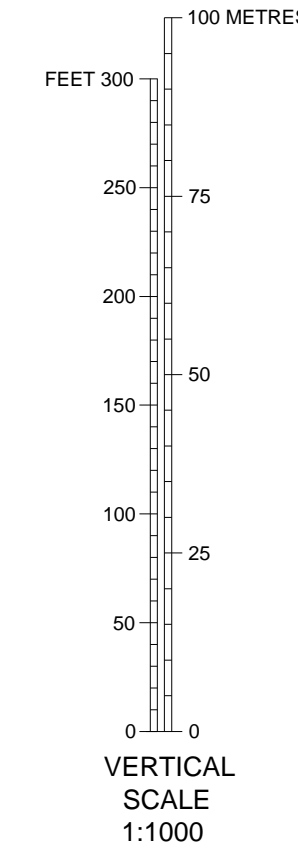

LEGEND	
IDENTIFICATION NUMBER	①
PRECISION APPROACH LIGHT	⊙
ANTENNA	⊙
ROAD	—
FENCE	—+—
DRAIN	▨
BUILDING	■

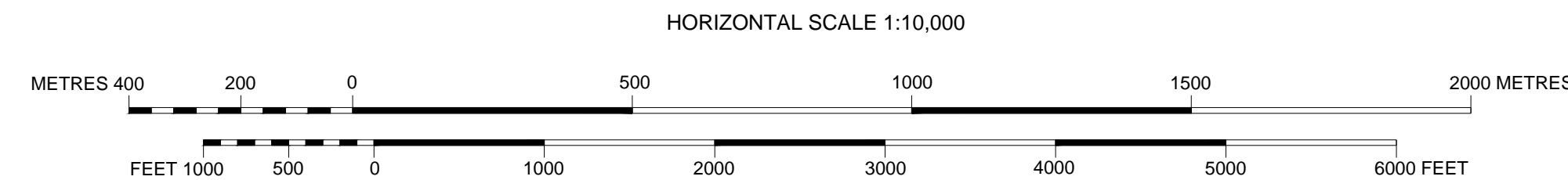

ORDER OF ACCURACY
HORIZONTAL : ±1m
VERTICAL : ±1m

AMENDMENT RECORD		
NO.	DATE	ENTERED BY

Intentionally Left Blank

PRECISION APPROACH TERRAIN CHART - ICAO

SINGAPORE/Singapore Changi

DISTANCES AND HEIGHTS IN METRES

RWY 02L

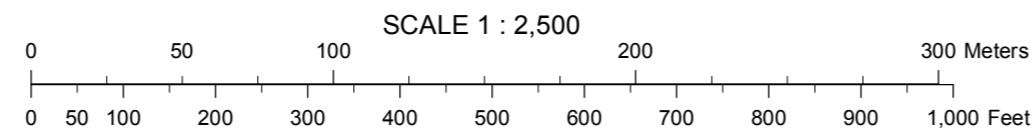
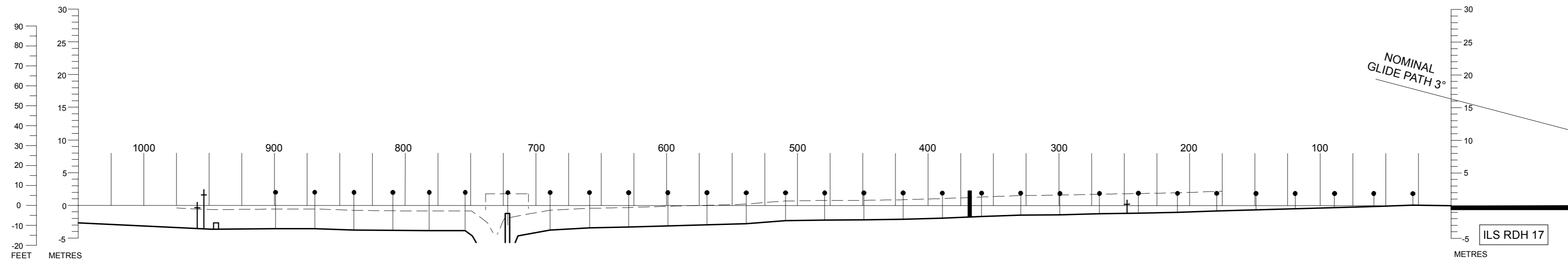
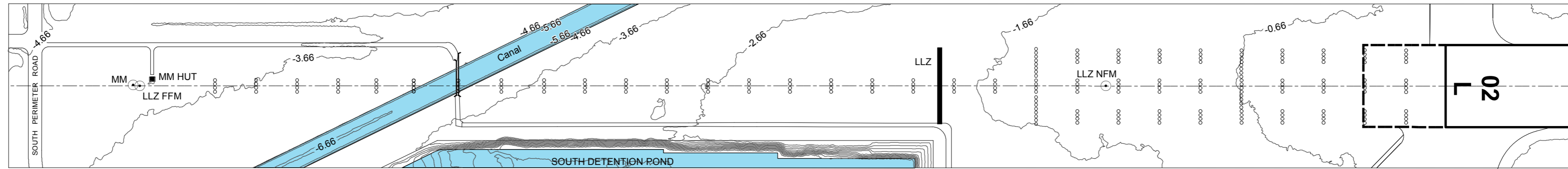

HORIZONTAL SCALE 1 : 2,500
VERTICAL SCALE 1 : 500
CONTOUR AND HEIGHTS ARE RELATED TO ELEVATION OF RWY THR

LEGEND		
BUILDING		
ROAD		
CONTOUR		
BRIDGE		
ANTENNA		
LOCALISER		LLZ
APPROACH LIGHTS		
CENTRE-LINE PROFILE		
DEVIATION AT LEAST +/- 3m FROM CENTERLINE PROFILE		
AMENDMENT RECORD		
NO.	DATE	ENTERED BY

Intentionally Left Blank

DISTANCES AND HEIGHTS IN METRES

PRECISION APPROACH TERRAIN CHART - ICAO

SINGAPORE/Singapore Changi
RWY 20C

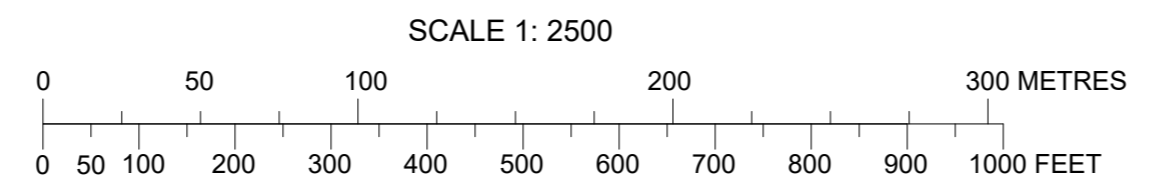
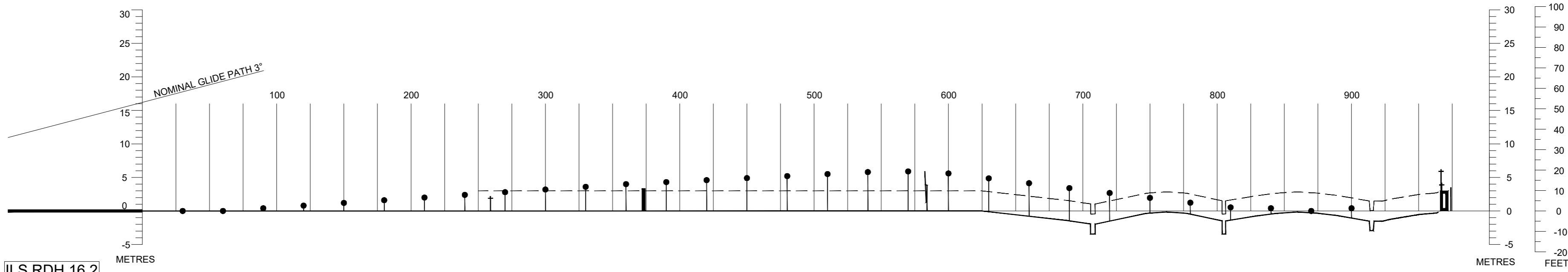
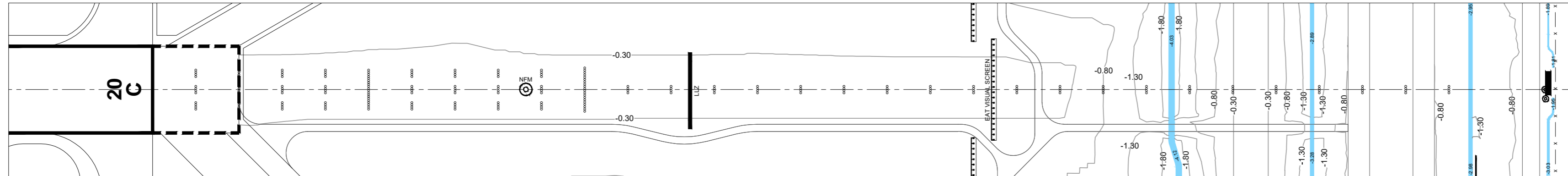

HORIZONTAL SCALE 1 : 2500
VERTICAL SCALE 1 : 500
CONTOUR AND HEIGHTS ARE RELATED TO ELEVATION OF RWY THR

LEGEND		
LOCALISER		LLZ
ANTENNA		NFM
DRAIN		[Blue line symbol]
FENCE		-x-x-
CONTOUR		~1.30~
PRECISION APPROACH LIGHT		o
ROAD		
EAT VISUAL SCREEN		[Dashed line symbol]
BUILDING		[Black rectangle symbol]
CENTRE-LINE PROFILE		—
DEVIATION AT LEAST +/- 3M FROM CENTRE-LINE PROFILE		- - -
JET BLAST FENCE		—
AMENDMENT RECORD		
NO.	DATE	ENTERED BY

Intentionally Left Blank

DISTANCES AND HEIGHTS IN METRES

PRECISION APPROACH TERRAIN CHART - ICAO

SINGAPORE/Singapore Changi
RWY 02R

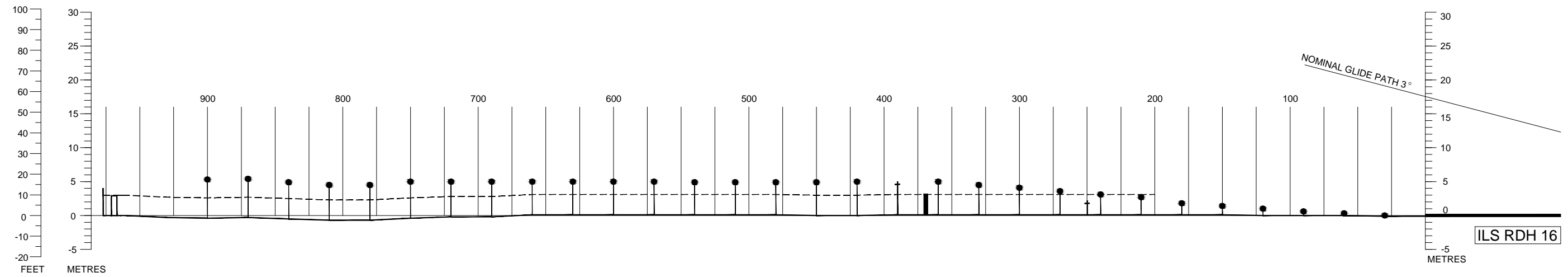
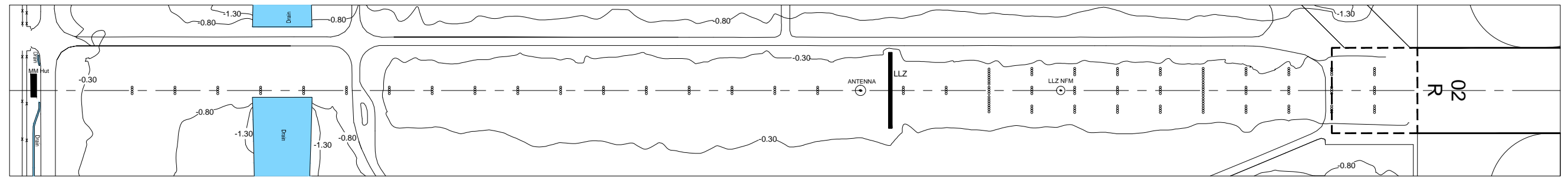

CAUTION: RWY 02R/20L NOT AVAILABLE FOR CIVIL USE UNTIL FURTHER ADVISED

HORIZONTAL SCALE 1 : 2500

VERTICAL SCALE 1 : 500

CONTOUR AND HEIGHTS ARE RELATED TO ELEVATION OF RWY THR

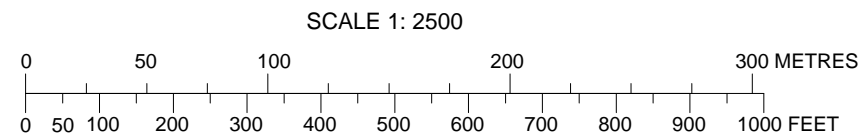

LEGEND		
ANTENNA		⊕ ↑
LOCALISER		LLZ
DRAIN		Blue shaded area
FENCE		-x-x-
CONTOUR		-1.30/
PRECISION APPROACH LIGHT		○ ●
ROAD		==
BUILDING		Black rectangle
CENTRE-LINE PROFILE		—
DEVIATION AT LEAST +/- 3M FROM CENTRE-LINE PROFILE		- - - -
AMENDMENT RECORD		
NO.	DATE	ENTERED BY

Intentionally Left Blank

DISTANCES AND HEIGHTS IN METRES

PRECISION APPROACH TERRAIN CHART - ICAO

SINGAPORE/Singapore Changi
RWY 20L

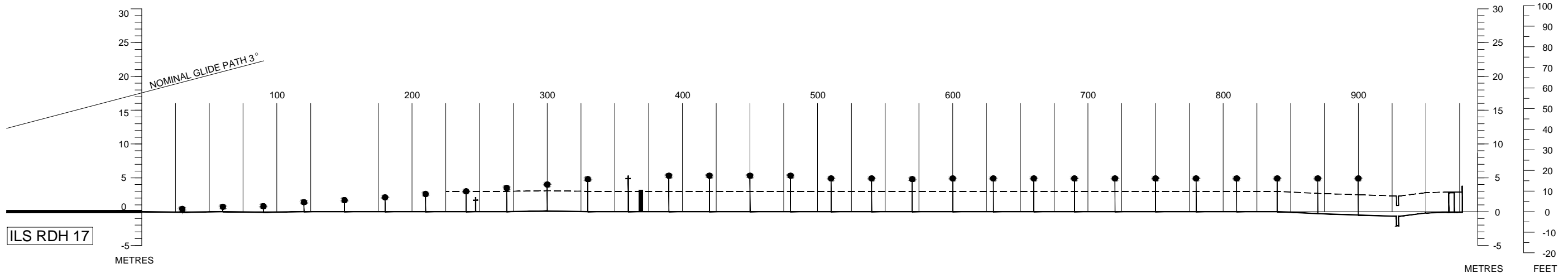
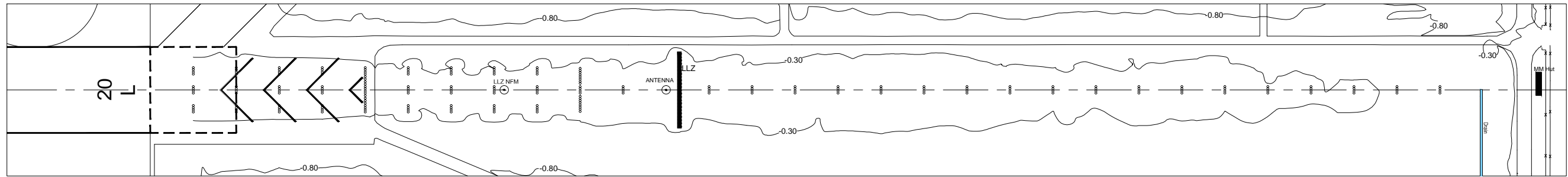

CAUTION: RWY 02R/20L NOT AVAILABLE FOR CIVIL USE UNTIL FURTHER ADVISED

HORIZONTAL SCALE 1 : 2500

VERTICAL SCALE 1 : 500

CONTOUR AND HEIGHTS ARE RELATED TO ELEVATION OF RWY THR

SCALE 1: 2500

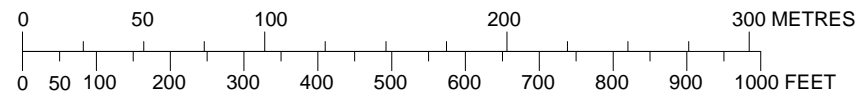

LEGEND		
ANTENNA		
LOCALISER		
BUILDING		
DRAIN		
FENCE		
CONTOUR		
APPROACH LIGHT		
ROAD		
CENTRE-LINE PROFILE		
DEVIATION AT LEAST +/- 3M FROM CENTRE-LINE PROFILE		
AMENDMENT RECORD		
NO.	DATE	ENTERED BY

Intentionally Left Blank

DISTANCES AND HEIGHTS IN METRES

PRECISION APPROACH TERRAIN CHART - ICAO

SINGAPORE/Singapore Changi
RWY 02C

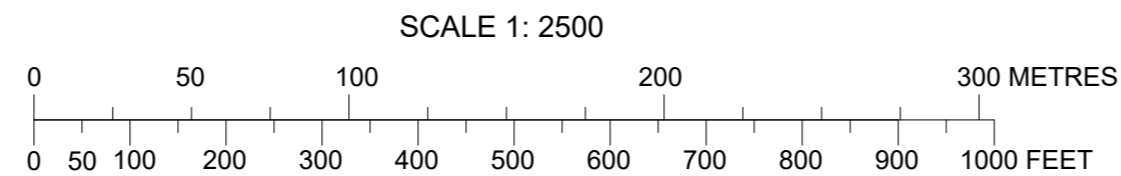
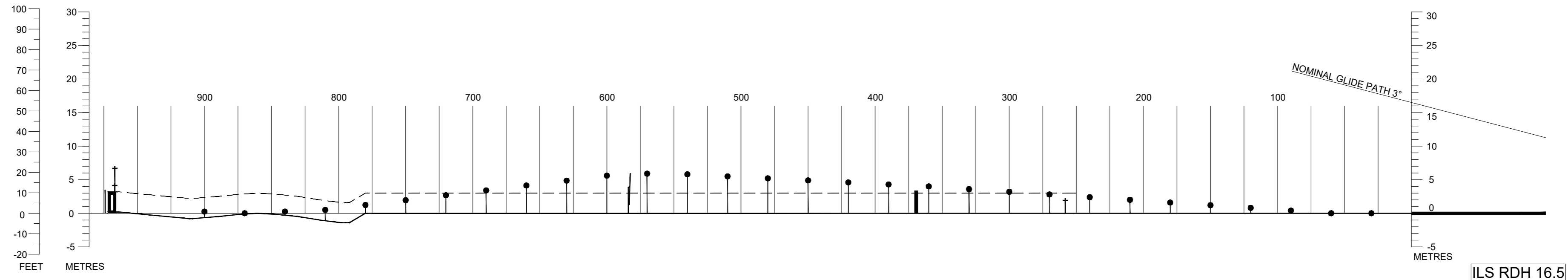
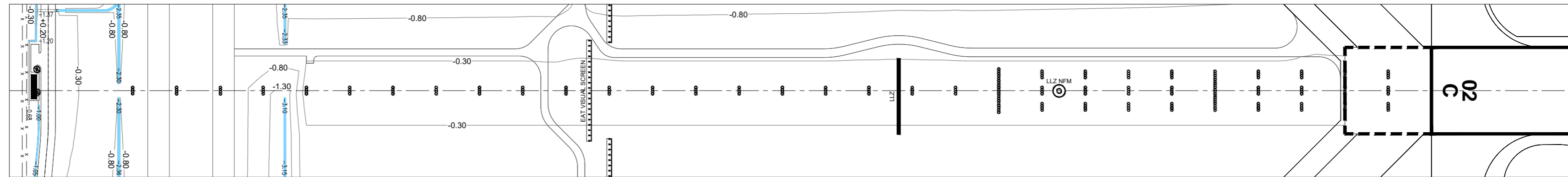

HORIZONTAL SCALE 1 : 2500

VERTICAL SCALE 1 : 500

CONTOUR AND HEIGHTS ARE RELATED TO ELEVATION OF RWY THR

LEGEND		
LOCALISER		LLZ
ANTENNA		⊕†
DRAIN		■
FENCE		-x-x-
CONTOUR		~1.30~
PRECISION APPROACH LIGHT		○●
ROAD		==
EAT VISUAL SCREEN		▬▬▬▬
BUILDING		■
CENTRE-LINE PROFILE		—
DEVIATION AT LEAST +/- 3M FROM CENTRE-LINE PROFILE		- - - - -
AMENDMENT RECORD		
NO.	DATE	ENTERED BY

Intentionally Left Blank

**STANDARD DEPARTURE CHART
RNAV (GNSS) -
INSTRUMENT (SID)**

TWR 118.6 / 118.25 APP 120.3 124.05 ACC 134.4	TRANSITION ALTITUDE 11 000ft
	D-ATIS AP ID-WSSS 128.6

**SINGAPORE/Singapore Changi
RWY 02C
ANITO DEPARTURES
ANITO 7A**

ELEV, ALT IN FEET
BEARINGS, TRACKS AND
RADIALS ARE MAGNETIC
VAR 0°23'E (2020)

DISTANCES IN NM

TEKONG
DVOR/DME 116.5
VTK 
01° 24' 55" N
104° 01' 20" E
60M

DER (RWY 02C)
01° 21' 45" N
103° 58' 57" E

MOXIB
01° 29' 33" N
104° 03' 15" E

EMRIX
01° 26' 06" N
104° 10' 40" E

HOSBA
01° 19' 48" N
104° 24' 18" E

VANBU
01° 06' 43" N
104° 27' 40" E

VIRET
00° 39' 40" N
104° 35' 11" E

GURES
00° 28' 14" N
104° 38' 35" E

IKIRO
00° 08' 49" N
104° 44' 20" E

ANITO
00° 17' 00" S
104° 52' 00" E

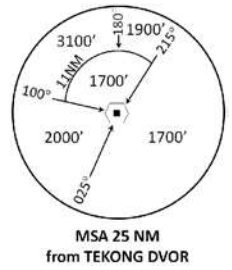

GENERAL INFORMATION

**INITIAL CLIMB
3000FT**

CAUTION: RWY 02R/20L NOT AVAILABLE FOR CIVIL USE UNTIL FURTHER ADVISED

- NOTE:** RADAR REQUIRED
- NOTE:** RNAV-1 NAVIGATION SPECIFICATION GNSS REQUIRED
- NOTE:** CLOSE-IN OBSTACLES (AIRCRAFT UP TO 80FT) EXIST ON TAXIWAYS WEST OF RUNWAY 02C
- NOTE:** ACFT UNABLE TO FLY THE SID PROFILE SHALL INFORM ATC PRIOR TO DEPARTURE AND EXPECT RADAR VECTORED IF NECESSARY
- NOTE:** WHEN TAKEN OFF THE SID, AS INSTRUCTED BY ATC, REFER TO ENR 1.5, SECTION 3, PARAGRAPH 3.3 [A] - FOR RWY 02C MINIMUM CLIMB GRADIENT
- NOTE:** REFER TO BACK PAGE FOR - FORMAL AND TABULAR DESCRIPTIONS - RADIO COM FAILURE PROCEDURES

PROCEDURE INFORMATION

SID SHALL NOT EXCEED IAS 230KTS UNTIL PASSING 4000FT AMSL AND NOT EXCEED IAS 250KTS UNTIL PASSING 10000FT AMSL.
CRUISING LEVELS WILL BE ISSUED AFTER TAKE-OFF BY SINGAPORE RADAR.
SID SHALL BE ON A MINIMUM CLIMB GRADIENT OF 5% UNTIL REACHING OR PASSING 2500FT, THEREAFTER 3.3%.

GND SPEED - KNOTS	75	100	150	200	250	300
5% V/V (fpm)	380	506	760	1013	1266	1519
3.3% V/V (fpm)	251	334	501	668	835	1003

NOT TO SCALE

ANITO 7A (SID) RNAV GNSS RWY 02C - DESCRIPTIONS

Formal & Abbreviated Descriptions

Formal Description	Abbreviated Description	Path Terminator	Fly-Over required
To MOXIB on course 023° at or above 2000ft, turn right.	MOXIB [M023; A020+; R] -	CF	N
To EMRIX at or above 4000ft.	EMRIX [A040+] -	TF	N
To HOSBA at or above 7000ft, turn right.	HOSBA [A070+; R] -	TF	N
To VANBU at or below 9000ft, turn left.	VANBU [A090-; L] -	TF	N
To VIRET at or above FL160, turn left.	VIRET [FL160+; L] -	TF	N
To GURES.	GURES -	TF	N
To IKIRO.	IKIRO -	TF	N
To ANITO.	ANITO	TF	N

Tabular Descriptions

Path Term	Waypoint Name	Fly-Over	Course °M(°T)	Distance (NM)	Turn Direction	Altitude	Speed Limit	Navigation Spec
CF	MOXIB	-	023(023.4)	8.0	R	A020+	-	RNAV1
TF	EMRIX	-	114(114.4)	8.0	-	A040+	-	RNAV1
TF	HOSBA	-	114(114.4)	15.0	R	A070+	-	RNAV1
TF	VANBU	-	165(165.4)	13.0	L	A090-	-	RNAV1
TF	VIRET	-	164(164.4)	28.0	L	FL160+	-	RNAV1
TF	GURES	-	163(163.4)	12.0	-	-	-	RNAV1
TF	IKIRO	-	163(163.4)	20.0	-	-	-	RNAV1
TF	ANITO	-	163(163.4)	27.0	-	-	-	RNAV1

Radio Communications Failure Procedure

1	SET TRANSPONDER TO MODE A/C CODE 7600
2	COMMUNICATIONS FAILURE OCCURS IMMEDIATELY AFTER DEPARTURE: PROCEED DIRECT TO NYLON HOLDING AREA (NHA) CLIMBING TO THE LAST ASSIGNED ALTITUDE, THEREAFTER REFER TO SINGAPORE AIP ON RADIO COMMUNICATIONS FAILURE PROCEDURE.

STANDARD DEPARTURE CHART
RNAV (GNSS) -
INSTRUMENT (SID)

TWR 118.6 / 118.25 APP 120.3 124.05 ACC 134.4	TRANSITION ALTITUDE 11 000ft
	D-ATIS AP ID-WSSS 128.6

SINGAPORE/Singapore Changi
RWY 20C
ANITO DEPARTURES
ANITO 8B

ELEV, ALT IN FEET
BEARINGS, TRACKS AND
RADIALS ARE MAGNETIC
VAR 0°23'E (2020)

DISTANCES IN NM

DER (RWY 20C)
01° 19' 42" N
103° 59' 05" E

IBIXU
01° 16' 21" N
103° 57' 40" E
A015

IBIVA
01° 13' 51" N
103° 56' 37" E
A025

ISNOM
01° 06' 29" N
103° 58' 26" E
A040

UPTEL
00° 59' 25" N
104° 07' 30" E
A060

ASOMI
01° 01' 42" N
104° 02' 07" E

IDKIV
00° 56' 52" N
104° 13' 33" E

TEKONG
DVOR/DME 116.5
VTK
01° 24' 55" N
104° 01' 20" E
60M

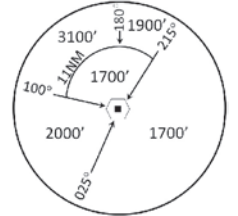

GIXEM
00° 49' 20" N
104° 25' 39" E

VASTI
00° 43' 20" N
104° 34' 06" E

VIRET
00° 39' 40" N
104° 35' 11" E
FL160

GURES
00° 28' 14" N
104° 38' 35" E

IKIRO
00° 08' 49" N
104° 44' 20" E

ANITO
00° 17' 00" S
104° 52' 00" E

GENERAL INFORMATION

INITIAL CLIMB
3000FT

CAUTION: RWY 02R/20L NOT AVAILABLE FOR CIVIL USE UNTIL FURTHER ADVISED

NOTE: RADAR REQUIRED

NOTE: RNAV-1 NAVIGATION SPECIFICATION GNSS REQUIRED

NOTE: ACFT UNABLE TO FLY THE SID PROFILE SHALL INFORM ATC PRIOR TO DEPARTURE AND EXPECT RADAR VECTURING IF NECESSARY

NOTE: WHEN TAKEN OFF THE SID, AS INSTRUCTED BY ATC, REFER TO ENR 1.5, SECTION 3, PARAGRAPH 3.4.1 - FOR RWY 20C MINIMUM CLIMB GRADIENT

NOTE: REFER TO BACK PAGE FOR
- FORMAL AND TABULAR DESCRIPTIONS
- RADIO COM FAILURE PROCEDURES

PROCEDURE INFORMATION

SID SHALL NOT EXCEED IAS 230KTS UNTIL PASSING 4000FT AMSL AND NOT EXCEED IAS 250KTS UNTIL PASSING 10000FT AMSL.

CRUISING LEVELS WILL BE ISSUED AFTER TAKE-OFF BY SINGAPORE RADAR.

SID SHALL BE ON A MINIMUM CLIMB GRADIENT OF 7% UNTIL REACHING OR PASSING 2500FT, THEREAFTER 3.3%.

GND SPEED - KNOTS	75	100	150	200	250	300
7% V/V (fpm)	532	709	1063	1418	1772	2127
3.3% V/V (fpm)	251	334	501	668	835	1003

NOT TO SCALE

ANITO 8B (SID) RNAV GNSS RWY 20C - DESCRIPTIONS

Formal & Abbreviated Descriptions

Formal Description	Abbreviated Description	Path Terminator	Fly-Over required
To IBIXU on course 203° at or above 1500ft.	IBIXU [M203; A015+] -	CF	N
To IBIVA at or above 2500ft, turn left.	IBIVA [A025+; L] -	TF	N
To ISNOM at or above 4000ft, turn left.	ISNOM [A040+; L] -	TF	N
To ASOMI, turn left.	ASOMI [L] -	TF	N
To UPTTEL at 6000ft.	UPTTEL [@A060] -	TF	N
To IDKIV, turn right.	IDKIV [R] -	TF	N
To GIXEM, turn right.	GIXEM [R] -	TF	N
To VASTI, turn right.	VASTI [R] -	TF	N
To VIRET at or above FL160.	VIRET [FL160+] -	TF	N
To GURES.	GURES -	TF	N
To IKIRO.	IKIRO -	TF	N
To ANITO.	ANITO	TF	N

Tabular Descriptions

Path Term	Waypoint Name	Fly-Over	Course °M(°T)	Distance (NM)	Turn Direction	Altitude	Speed Limit	Navigation Spec
CF	IBIXU	-	203(203.4)	4.0	-	A015+	-	RNAV1
TF	IBIVA	-	203(203.4)	3.0	L	A025+	-	RNAV1
TF	ISNOM	-	166(166.4)	8.0	L	A040+	-	RNAV1
TF	ASOMI	-	142(142.4)	6.0	L	-	-	RNAV1
TF	UPTTEL	-	112(112.4)	6.0	-	@A060	-	RNAV1
TF	IDKIV	-	112(112.4)	7.0	R	-	-	RNAV1
TF	GIXEM	-	121(121.4)	14.0	R	-	-	RNAV1
TF	VASTI	-	125(125.4)	10.0	R	-	-	RNAV1
TF	VIRET	-	163(163.4)	4.0	-	FL160+	-	RNAV1
TF	GURES	-	163(163.4)	12.0	-	-	-	RNAV1
TF	IKIRO	-	163(163.4)	20.0	-	-	-	RNAV1
TF	ANITO	-	163(163.4)	27.0	-	-	-	RNAV1

Radio Communications Failure Procedure

1	SET TRANSPONDER TO MODE A/C CODE 7600
2	COMMUNICATIONS FAILURE OCCURS IMMEDIATELY AFTER DEPARTURE: PROCEED DIRECT TO SAMKO HOLDING AREA (SHA) CLIMBING TO THE LAST ASSIGNED ALTITUDE, THEREAFTER REFER TO SINGAPORE AIP ON RADIO COMMUNICATIONS FAILURE PROCEDURE.

STANDARD DEPARTURE CHART
RNAV (GNSS) -
INSTRUMENT (SID)

TWR 118.6 / 118.25
APP 120.3
124.05
ACC 134.4

TRANSITION ALTITUDE
11 000ft

D-ATIS AP ID-WSSS
128.6

SINGAPORE/Singapore Changi
RWY 02R
ANITO DEPARTURES (RADAR)
ANITO 1C

ELEV, ALT IN FEET
BEARINGS, TRACKS AND
RADIALS ARE MAGNETIC
VAR 0°23'E (2020)

DISTANCES IN NM

TEKONG
DVOR/DME 116.5
VTK
01°24'55"N
104°01'20"E
60M

DER (RWY02R)
01°21'22"N
104°00'51"E

HOSBA
01°19'48"N
104°24'18"E
A070

VANBU
01°06'43"N
104°27'40"E
A090

VIRET
00°39'40"N
104°35'11"E
FL160

GURES
00°28'14"N
104°38'35"E

IKIRO
00°08'49"N
104°44'20"E

ANITO
00°17'00"S
104°52'00"E

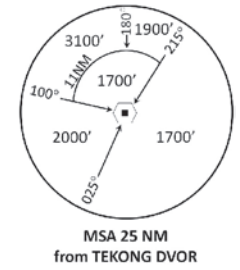

EXPECT RADAR vectors to waypoint HOSBA

GENERAL INFORMATION

INITIAL CLIMB
3000FT

CAUTION: RWY 02R/20L NOT AVAILABLE FOR CIVIL USE UNTIL FURTHER ADVISED

NOTE: RADAR REQUIRED

NOTE: RNAV-1 NAVIGATION SPECIFICATION GNSS REQUIRED

NOTE: ACFT UNABLE TO FLY THE SID PROFILE SHALL INFORM ATC PRIOR TO DEPARTURE AND EXPECT RADAR VECTORING IF NECESSARY

NOTE: WHEN TAKEN OFF THE SID, AS INSTRUCTED BY ATC, REFER TO ENR 1.5, SECTION 3, PARAGRAPH 3.5 - FOR RWY 02R MINIMUM CLIMB GRADIENT

NOTE: REFER TO BACK PAGE FOR
- FORMAL AND TABULAR DESCRIPTIONS
- RADIO COM FAILURE PROCEDURES

PROCEDURE INFORMATION

SID SHALL NOT EXCEED IAS 230KTS UNTIL PASSING 4000FT AMSL AND NOT EXCEED IAS 250KTS UNTIL PASSING 10000FT AMSL.

CRUISING LEVELS WILL BE ISSUED AFTER TAKE-OFF BY SINGAPORE RADAR.

SID SHALL BE ON A MINIMUM CLIMB GRADIENT OF 5% UNTIL REACHING OR PASSING 2500FT, THEREAFTER 3.3%.

GND SPEED - KNOTS	75	100	150	200	250	300
5% V/V (fpm)	380	506	760	1013	1266	1519
3.3% V/V (fpm)	251	334	501	668	835	1003

NOT TO SCALE

ANITO 1C (SID) RNAV GNSS RWY 02R - DESCRIPTIONS

Formal & Abbreviated Descriptions

Formal Description	Abbreviated Description	Path Terminator	Fly-Over required
Climb heading 023°, Gradient 5% to 2500ft, thence 3.3%. Expect radar vectors to waypoint HOSBA.	-	VA	N
To HOSBA at or above 7000ft.	HOSBA [A070+] -	DF	N
To VANBU at or below 9000ft, turn left.	VANBU [A090-; L] -	TF	N
To VIRET at or above FL160, turn left.	VIRET [FL160+; L] -	TF	N
To GURES.	GURES -	TF	N
To IKIRO.	IKIRO -	TF	N
To ANITO.	ANITO	TF	N

Tabular Descriptions

Path Term	Waypoint Name	Fly-Over	Course °M(°T)	Distance (NM)	Turn Direction	Altitude	Speed Limit	Navigation Spec
VA	-	-	023(023.4)	-	-	A030	-	-
DF	HOSBA	-	-	-	-	A070+	-	RNAV1
TF	VANBU	-	165(165.4)	13.0	L	A090-	-	RNAV1
TF	VIRET	-	164(164.4)	28.0	L	FL160+	-	RNAV1
TF	GURES	-	163(163.3)	12.0	-	-	-	RNAV1
TF	IKIRO	-	163(163.3)	20.0	-	-	-	RNAV1
TF	ANITO	-	163(163.3)	27.0	-	-	-	RNAV1

Radio Communications Failure Procedure

1	SET TRANSPONDER TO MODE A/C CODE 7600
2	COMMUNICATIONS FAILURE OCCURS IMMEDIATELY AFTER DEPARTURE: PROCEED DIRECT TO NYLON HOLDING AREA (NHA) CLIMBING TO THE LAST ASSIGNED ALTITUDE, THEREAFTER REFER TO SINGAPORE AIP ON RADIO COMMUNICATIONS FAILURE PROCEDURE.

STANDARD DEPARTURE CHART
RNAV (GNSS) -
INSTRUMENT (SID)

TWR 118.6 / 118.25
APP 120.3
124.05
ACC 134.4

TRANSITION ALTITUDE
11 000ft

D-ATIS AP ID-WSSS
128.6

SINGAPORE/Singapore Changi
RWY 20L
ANITO DEPARTURES
ANITO 1D

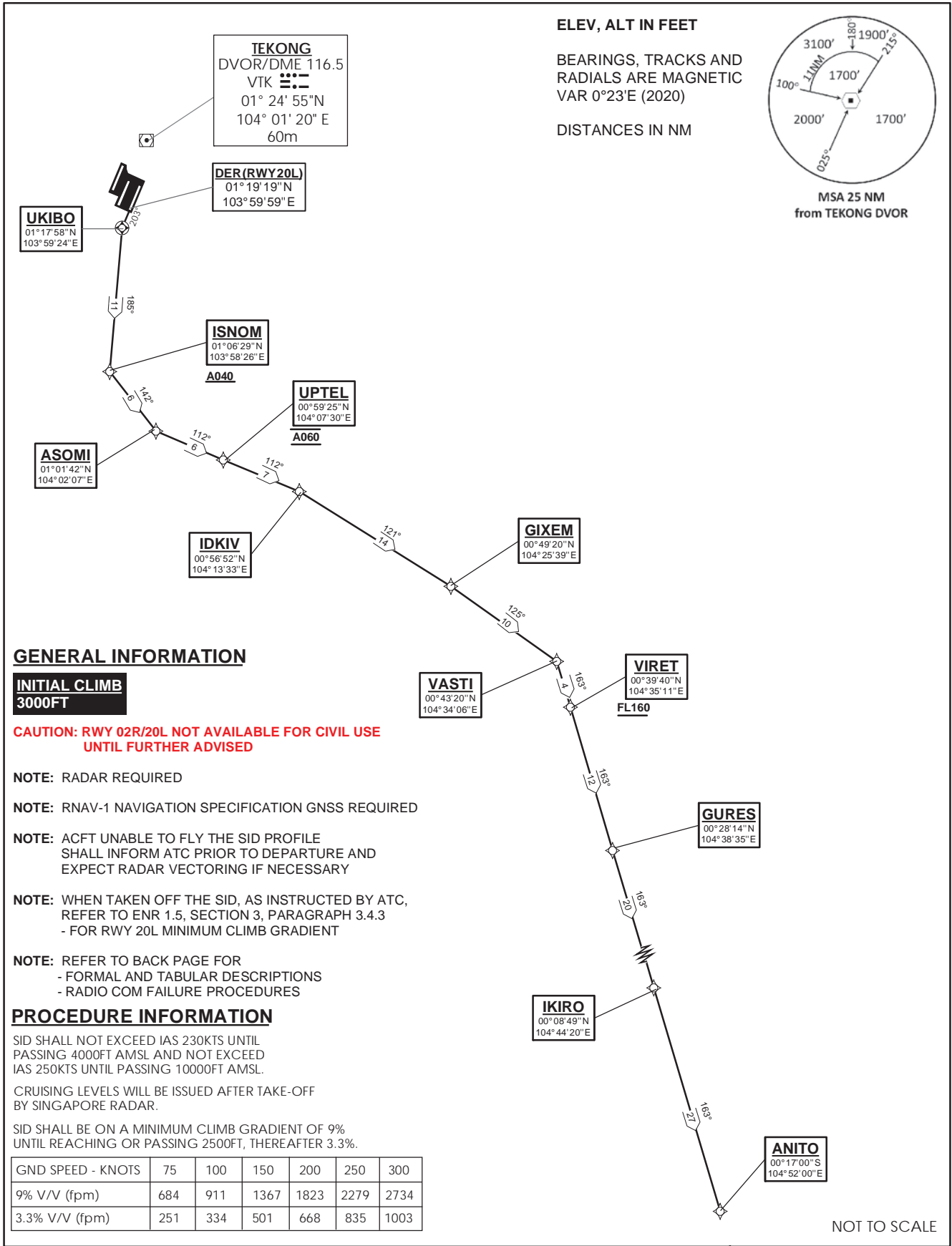

ANITO 1D (SID) RNAV GNSS RWY 20L - DESCRIPTIONS

Formal & Abbreviated Descriptions

Formal Description	Abbreviated Description	Path Terminator	Fly-Over required
To UKIBO on course 203°, turn left.	UKIBO [M203; L] -	CF	N
To ISNOM at or above 4000ft, turn left.	ISNOM [A040+; L] -	TF	N
To ASOMI, turn left.	ASOMI [L] -	TF	N
To UPTTEL at 6000ft.	UPTTEL [@A060] -	TF	N
To IDKIV, turn right.	IDKIV [R] -	TF	N
To GIXEM, turn right.	GIXEM [R] -	TF	N
To VASTI, turn right.	VASTI [R] -	TF	N
To VIRET at or above FL160.	VIRET [FL160+] -	TF	N
To GURES.	GURES -	TF	N
To IKIRO.	IKIRO -	TF	N
To ANITO.	ANITO	TF	N

Tabular Descriptions

Path Term	Waypoint Name	Fly-Over	Course °M(°T)	Distance (NM)	Turn Direction	Altitude	Speed Limit	Navigation Spec
CF	UKIBO	Y	203(203.4)	1.5	L	-	-	RNAV1
TF	ISNOM	-	185(185.4)	11.0	L	A040+	-	RNAV1
TF	ASOMI	-	142(142.4)	6.0	L	-	-	RNAV1
TF	UPTTEL	-	112(112.4)	6.0	-	@A060	-	RNAV1
TF	IDKIV	-	112(112.4)	7.0	R	-	-	RNAV1
TF	GIXEM	-	121(121.4)	14.0	R	-	-	RNAV1
TF	VASTI	-	125(125.4)	10.0	R	-	-	RNAV1
TF	VIRET	-	163(163.4)	4.0	-	FL160+	-	RNAV1
TF	GURES	-	163(163.4)	12.0	-	-	-	RNAV1
TF	IKIRO	-	163(163.4)	20.0	-	-	-	RNAV1
TF	ANITO	-	163(163.4)	27.0	-	-	-	RNAV1

Radio Communications Failure Procedure

1	SET TRANSPONDER TO MODE A/C CODE 7600
2	COMMUNICATIONS FAILURE OCCURS IMMEDIATELY AFTER DEPARTURE: PROCEED DIRECT TO SAMKO HOLDING AREA (SHA) CLIMBING TO THE LAST ASSIGNED ALTITUDE, THEREAFTER REFER TO SINGAPORE AIP ON RADIO COMMUNICATIONS FAILURE PROCEDURE.

STANDARD DEPARTURE CHART
RNAV (GNSS) -
INSTRUMENT (SID)

TWR 118.6 / 118.25 APP 120.3 124.05 ACC 134.4	TRANSITION ALTITUDE 11 000ft
	D-ATIS AP ID-WSSS 128.6

SINGAPORE/Singapore Changi
RWY 02L
ANITO DEPARTURES
ANITO 7E

ELEV, ALT IN FEET
BEARINGS, TRACKS AND
RADIALS ARE MAGNETIC
VAR 0°23'E (2022)

DISTANCES IN NM

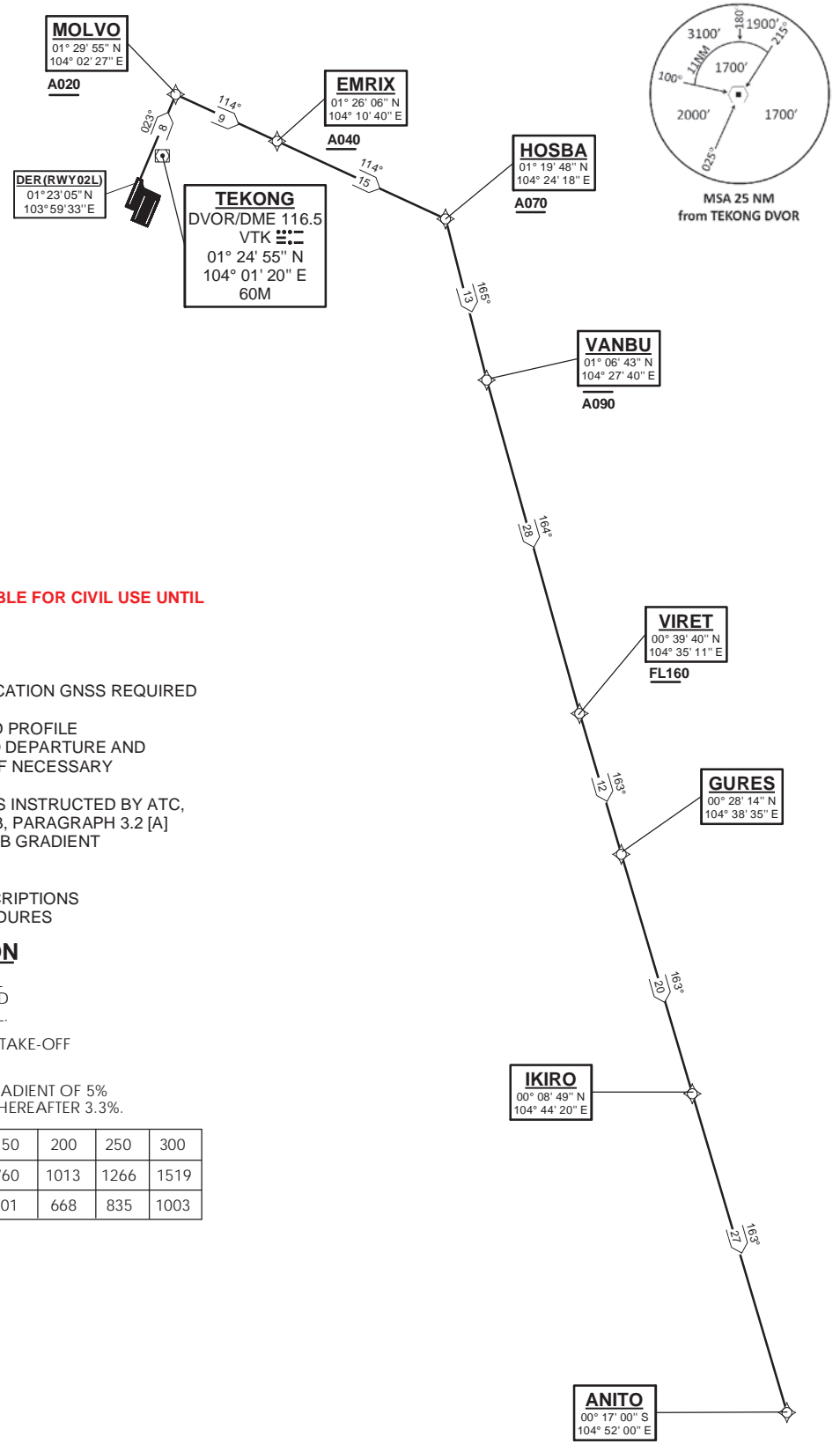

GENERAL INFORMATION

INITIAL CLIMB
3000FT

CAUTION: RWY 02R/20L NOT AVAILABLE FOR CIVIL USE UNTIL FURTHER ADVISED

- NOTE:** RADAR REQUIRED
- NOTE:** RNAV-1 NAVIGATION SPECIFICATION GNSS REQUIRED
- NOTE:** ACFT UNABLE TO FLY THE SID PROFILE SHALL INFORM ATC PRIOR TO DEPARTURE AND EXPECT RADAR VECTORING IF NECESSARY
- NOTE:** WHEN TAKEN OFF THE SID, AS INSTRUCTED BY ATC, REFER TO ENR 1.5, SECTION 3, PARAGRAPH 3.2 [A] - FOR RWY 02L MINIMUM CLIMB GRADIENT
- NOTE:** REFER TO BACK PAGE FOR
 - FORMAL AND TABULAR DESCRIPTIONS
 - RADIO COM FAILURE PROCEDURES

PROCEDURE INFORMATION

SID SHALL NOT EXCEED IAS 230KTS UNTIL PASSING 4000FT AMSL AND NOT EXCEED IAS 250KTS UNTIL PASSING 10000FT AMSL.
CRUISING LEVELS WILL BE ISSUED AFTER TAKE-OFF BY SINGAPORE RADAR.
SID SHALL BE ON A MINIMUM CLIMB GRADIENT OF 5% UNTIL REACHING OR PASSING 2500FT, THEREAFTER 3.3%.

GND SPEED - KNOTS	75	100	150	200	250	300
5% V/V (fpm)	380	506	760	1013	1266	1519
3.3% V/V (fpm)	251	334	501	668	835	1003

NOT TO SCALE

ANITO 7E (SID) RNAV GNSS RWY 02L - DESCRIPTIONS

Formal & Abbreviated Descriptions

Formal Description	Abbreviated Description	Path Terminator	Fly-Over required
To MOLVO on course 023° at or above 2000ft, turn right.	MOLVO [M023; A020+; R] -	CF	N
To EMRIX at or above 4000ft.	EMRIX [A040+] -	TF	N
To HOSBA at or above 7000ft, turn right.	HOSBA [A070+; R] -	TF	N
To VANBU at or below 9000ft, turn left.	VANBU [A090-; L] -	TF	N
To VIRET at or above FL160, turn left.	VIRET [FL160+; L] -	TF	N
To GURES.	GURES -	TF	N
To IKIRO.	IKIRO -	TF	N
To ANITO.	ANITO	TF	N

Tabular Descriptions

Path Term	Waypoint Name	Fly-Over	Course °M(°T)	Distance (NM)	Turn Direction	Altitude	Speed Limit	Navigation Spec
CF	MOLVO	-	023(023.4)	8.0	R	A020+	-	RNAV1
TF	EMRIX	-	114(114.4)	9.0	-	A040+	-	RNAV1
TF	HOSBA	-	114(114.4)	15.0	R	A070+	-	RNAV1
TF	VANBU	-	165(165.4)	13.0	L	A090-	-	RNAV1
TF	VIRET	-	164(164.4)	28.0	L	FL160+	-	RNAV1
TF	GURES	-	163(163.3)	12.0	-	-	-	RNAV1
TF	IKIRO	-	163(163.3)	20.0	-	-	-	RNAV1
TF	ANITO	-	163(163.3)	27.0	-	-	-	RNAV1

Radio Communications Failure Procedure

1	SET TRANSPONDER TO MODE A/C CODE 7600
2	<p>COMMUNICATIONS FAILURE OCCURS IMMEDIATELY AFTER DEPARTURE:</p> <p>PROCEED DIRECT TO NYLON HOLDING AREA (NHA) CLIMBING TO THE LAST ASSIGNED ALTITUDE, THEREAFTER REFER TO SINGAPORE AIP ON RADIO COMMUNICATIONS FAILURE PROCEDURE.</p>

STANDARD DEPARTURE CHART
RNAV (GNSS) -
INSTRUMENT (SID)

TWR 118.6 / 118.25 APP 120.3 124.05 ACC 134.4	TRANSITION ALTITUDE 11 000ft
	D-ATIS AP ID-WSSS 128.6

SINGAPORE/Singapore Changi
RWY 20R
ANITO DEPARTURES
ANITO 8F

ELEV, ALT IN FEET
BEARINGS, TRACKS AND
RADIALS ARE MAGNETIC
VAR 0°23'E (2020)

DISTANCES IN NM

DER (RWY 20R)
01° 20' 47" N
103° 58' 35" E

LEDOX
01° 16' 42" N
103° 56' 51" E
A015

TEKONG
DVOR/DME 116.5
VTK
01° 24' 55" N
104° 01' 20" E
60M

LETGO
01° 14' 11" N
103° 55' 48" E
A025

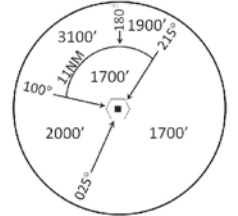

ISNOM
01° 06' 29" N
103° 58' 26" E
A040

UPTEL
00° 59' 25" N
104° 07' 30" E
A060

ASOMI
01° 01' 42" N
104° 02' 07" E

IDKIV
00° 56' 52" N
104° 13' 33" E

GIXEM
00° 49' 20" N
104° 25' 39" E

VASTI
00° 43' 20" N
104° 34' 06" E

VIRET
00° 39' 40" N
104° 35' 11" E
FL160

GURES
00° 28' 14" N
104° 38' 35" E

IKIRO
00° 08' 49" N
104° 44' 20" E

ANITO
00° 17' 00" S
104° 52' 00" E

GENERAL INFORMATION

INITIAL CLIMB
3000FT

CAUTION: RWY 02R/20L NOT AVAILABLE FOR CIVIL USE UNTIL FURTHER ADVISED

NOTE: RADAR REQUIRED

NOTE: RNAV-1 NAVIGATION SPECIFICATION GNSS REQUIRED

NOTE: ACFT UNABLE TO FLY THE SID PROFILE SHALL INFORM ATC PRIOR TO DEPARTURE AND EXPECT RADAR VECTORED IF NECESSARY

NOTE: WHEN TAKEN OFF THE SID, AS INSTRUCTED BY ATC, REFER TO ENR 1.5, SECTION 3, PARAGRAPH 3.4.2 - FOR RWY 20R MINIMUM CLIMB GRADIENT

NOTE: REFER TO BACK PAGE FOR
- FORMAL AND TABULAR DESCRIPTIONS
- RADIO COM FAILURE PROCEDURES

PROCEDURE INFORMATION

SID SHALL NOT EXCEED IAS 230KTS UNTIL PASSING 4000FT AMSL AND NOT EXCEED IAS 250KTS UNTIL PASSING 10000FT AMSL.

CRUISING LEVELS WILL BE ISSUED AFTER TAKE-OFF BY SINGAPORE RADAR.

SID SHALL BE ON A MINIMUM CLIMB GRADIENT OF 6% UNTIL REACHING OR PASSING 2500FT, THEREAFTER 3.3%.

GND SPEED - KNOTS	75	100	150	200	250	300
6% V/V (fpm)	456	608	911	1215	1518	1821
3.3% V/V (fpm)	251	334	501	668	835	1003

NOT TO SCALE

ANITO 8F (SID) RNAV GNSS RWY 20R - DESCRIPTIONS

Formal & Abbreviated Descriptions

Formal Description	Abbreviated Description	Path Terminator	Fly-Over required
To LEDOX on course 203° at or above 1500ft.	LEDOX [M203; A015+] -	CF	N
To LETGO at or above 2500ft, turn left.	LETGO [A025+; L] -	TF	N
To ISNOM at or above 4000ft, turn left.	ISNOM [A040+; L] -	TF	N
To ASOMI, turn left.	ASOMI [L] -	TF	N
To UPTTEL at 6000ft.	UPTTEL [@A060] -	TF	N
To IDKIV, turn right.	IDKIV [R] -	TF	N
To GIXEM, turn right.	GIXEM [R] -	TF	N
To VASTI, turn right.	VASTI [R] -	TF	N
To VIRET at or above FL160.	VIRET [FL160+] -	TF	N
To GURES.	GURES -	TF	N
To IKIRO.	IKIRO -	TF	N
To ANITO.	ANITO	TF	N

Tabular Descriptions

Path Term	Waypoint Name	Fly-Over	Course °M(°T)	Distance (NM)	Turn Direction	Altitude	Speed Limit	Navigation Spec
CF	LEDOX	-	203(203.4)	5.0	-	A015+	-	RNAV1
TF	LETGO	-	203(203.4)	3.0	L	A025+	-	RNAV1
TF	ISNOM	-	161(161.4)	8.0	L	A040+	-	RNAV1
TF	ASOMI	-	142(142.4)	6.0	L	-	-	RNAV1
TF	UPTTEL	-	112(112.4)	6.0	-	@A060	-	RNAV1
TF	IDKIV	-	112(112.4)	7.0	R	-	-	RNAV1
TF	GIXEM	-	121(121.4)	14.0	R	-	-	RNAV1
TF	VASTI	-	125(125.4)	10.0	R	-	-	RNAV1
TF	VIRET	-	163(163.4)	4.0	-	FL160+	-	RNAV1
TF	GURES	-	163(163.4)	12.0	-	-	-	RNAV1
TF	IKIRO	-	163(163.4)	20.0	-	-	-	RNAV1
TF	ANITO	-	163(163.4)	27.0	-	-	-	RNAV1

Radio Communications Failure Procedure

1	SET TRANSPONDER TO MODE A/C CODE 7600
2	COMMUNICATIONS FAILURE OCCURS IMMEDIATELY AFTER DEPARTURE: PROCEED DIRECT TO SAMKO HOLDING AREA (SHA) CLIMBING TO THE LAST ASSIGNED ALTITUDE, THEREAFTER REFER TO SINGAPORE AIP ON RADIO COMMUNICATIONS FAILURE PROCEDURE.

STANDARD DEPARTURE CHART
RNAV (GNSS) -
INSTRUMENT (SID)

TWR 118.6 / 118.25
APP 120.3
124.05
ACC 133.25

TRANSITION ALTITUDE
11 000ft

D-ATIS AP ID-WSSS
128.6

SINGAPORE/Singapore Changi
RWY 02C
AROSO DEPARTURES
AROSO 3A

ELEV, ALT IN FEET
BEARINGS, TRACKS AND
RADIALS ARE MAGNETIC
VAR 0°23'E (2020)

DISTANCES IN NM

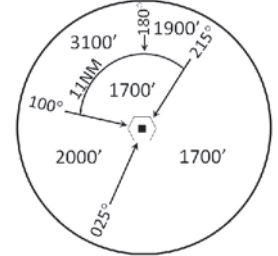

MSA 25 NM
from TEKONG DVOR

AROSO
02° 08' 46" N
103° 24' 21" E

GENERAL INFORMATION

INITIAL CLIMB
3000FT

CAUTION: RWY 02R/20L NOT AVAILABLE FOR CIVIL USE UNTIL FURTHER ADVISED

NOTE: RADAR REQUIRED

NOTE: RNAV-1 NAVIGATION SPECIFICATION GNSS REQUIRED

NOTE: CLOSE-IN OBSTACLES (AIRCRAFT UP TO 80FT) EXIST ON TAXIWAYS WEST OF RUNWAY 02C

NOTE: ACFT UNABLE TO FLY THE SID PROFILE SHALL INFORM ATC PRIOR TO DEPARTURE AND EXPECT RADAR VECTORED IF NECESSARY

NOTE: WHEN TAKEN OFF THE SID, AS INSTRUCTED BY ATC, REFER TO ENR 1.5, SECTION 3, PARAGRAPH 3.3 [A] - FOR RWY 02C MINIMUM CLIMB GRADIENT

NOTE: REFER TO BACK PAGE FOR
- FORMAL AND TABULAR DESCRIPTIONS
- RADIO COM FAILURE PROCEDURES

PROCEDURE INFORMATION

SID SHALL NOT EXCEED IAS 230KTS UNTIL PASSING 4000FT AMSL AND NOT EXCEED IAS 250KTS UNTIL PASSING 10000FT AMSL.

CRUISING LEVELS WILL BE ISSUED AFTER TAKE-OFF BY SINGAPORE RADAR.

SID SHALL BE ON A MINIMUM CLIMB GRADIENT OF 5% UNTIL REACHING OR PASSING 2500FT, THEREAFTER 3.3%.

GND SPEED - KNOTS	75	100	150	200	250	300
5% V/V (fpm)	380	506	760	1013	1266	1519
3.3% V/V (fpm)	251	334	501	668	835	1003

AKMET
01° 53' 55" N
103° 43' 39" E
A110

AKOMA
01° 45' 22" N
103° 54' 43" E
A070

MOXIB
01° 29' 33" N
104° 03' 15" E
A020

TEKONG
DVOR/DME 116.5
VTK
01° 24' 55" N
104° 01' 20" E
60M

DER (RWY 02C)
01° 21' 45" N
103° 59' 57" E

NOT TO SCALE

AROSO 3A (SID) RNAV GNSS RWY 02C - DESCRIPTIONS

Formal & Abbreviated Descriptions

Formal Description	Abbreviated Description	Path Terminator	Fly-Over required
To MOXIB on course 023° at or above 2000ft, turn left.	MOXIB [M023; A020+; L] -	CF	N
To AKOMA at or above 7000ft, turn left.	AKOMA [A070+; L] -	TF	N
To AKMET at or above 11000ft.	AKMET [A110+] -	TF	N
To AROSO.	AROSO	TF	N

Tabular Descriptions

Path Term	Waypoint Name	Fly-Over	Course °M(°T)	Distance (NM)	Turn Direction	Altitude	Speed Limit	Navigation Spec
CF	MOXIB	-	023(023.4)	8.0	L	A020+	-	RNAV1
TF	AKOMA	-	331(331.4)	18.0	L	A070+	-	RNAV1
TF	AKMET	-	307(307.4)	14.0	-	A110+	-	RNAV1
TF	AROSO	-	307(307.4)	24.0	-	-	-	RNAV1

Radio Communications Failure Procedure

1	SET TRANSPONDER TO MODE A/C CODE 7600
2	<p>COMMUNICATIONS FAILURE OCCURS IMMEDIATELY AFTER DEPARTURE:</p> <p>PROCEED DIRECT TO NYLON HOLDING AREA (NHA) CLIMBING TO THE LAST ASSIGNED ALTITUDE, THEREAFTER REFER TO SINGAPORE AIP ON RADIO COMMUNICATIONS FAILURE PROCEDURE.</p>

STANDARD DEPARTURE CHART
RNAV (GNSS) -
INSTRUMENT (SID)

TWR 118.6 / 118.25
APP 120.3
124.05
ACC 133.25

TRANSITION ALTITUDE
11 000ft

D-ATIS AP ID-WSSS
128.6

SINGAPORE/Singapore Changi
RWY 20C
AROSO DEPARTURES
AROSO 5B

ELEV, ALT IN FEET
BEARINGS, TRACKS AND
RADIALS ARE MAGNETIC
VAR 0°23'E (2022)

NOT TO SCALE

DISTANCES IN NM

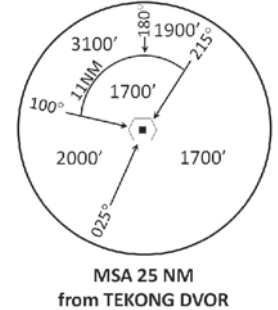

AROSO
02° 08' 46" N
103° 24' 21" E

AKMET
01° 53' 55" N
103° 43' 39" E

AKOMA
01° 45' 22" N
103° 54' 43" E
A110

GENERAL INFORMATION

INITIAL CLIMB
3000FT

CAUTION: RWY 02R/20L NOT AVAILABLE FOR CIVIL USE UNTIL FURTHER ADVISED

NOTE: RADAR REQUIRED

NOTE: RNAV-1 NAVIGATION SPECIFICATION GNSS REQUIRED

NOTE: ACFT UNABLE TO FLY THE SID PROFILE
SHALL INFORM ATC PRIOR TO DEPARTURE AND
EXPECT RADAR VECTORED IF NECESSARY

NOTE: WHEN TAKEN OFF THE SID, AS INSTRUCTED BY ATC,
REFER TO ENR 1.5, SECTION 3, PARAGRAPH 3.4.1
- FOR RWY 20C MINIMUM CLIMB GRADIENT

NOTE: REFER TO BACK PAGE FOR
- FORMAL AND TABULAR DESCRIPTIONS
- RADIO COM FAILURE PROCEDURES

PROCEDURE INFORMATION

SID SHALL NOT EXCEED IAS 230KTS UNTIL
PASSING 4000FT AMSL AND NOT EXCEED
IAS 250KTS UNTIL PASSING 10000FT AMSL.

CRUISING LEVELS WILL BE ISSUED AFTER TAKE-OFF
BY SINGAPORE RADAR.

SID SHALL BE ON A MINIMUM CLIMB GRADIENT OF 7%
UNTIL REACHING OR PASSING 2500FT, THEREAFTER 3.3%.

GND SPEED - KNOTS	75	100	150	200	250	300
7% V/V (fpm)	532	709	1063	1418	1772	2127
3.3% V/V (fpm)	251	334	501	668	835	1003

DER (RWY 20C)
01° 19' 42" N
103° 59' 05" E

IBIXU
01° 16' 21" N
103° 57' 40" E
A015

IBIVA
01° 13' 51" N
103° 56' 37" E
A025

DUBOT
01° 08' 46" N
104° 01' 03" E
A040

TEKONG
DVOR/DME 116.5
VTK
01° 24' 55" N
104° 01' 20" E
60M
A070

SALRU
01° 17' 01" N
104° 08' 02" E

ADPON
01° 12' 03" N
104° 05' 14" E

AROSO 5B (SID) RNAV GNSS RWY 20C - DESCRIPTIONS

Formal & Abbreviated Descriptions

Formal Description	Abbreviated Description	Path Terminator	Fly-Over required
To IBIXU on course 203° at or above 1500ft.	IBIXU [M203; A015+] -	CF	N
To IBIVA at or above 2500ft, turn left.	IBIVA [A025+; L] -	TF	N
To DUBOT at or above 4000ft, turn left.	DUBOT [A040+; L] -	TF	N
To ADPON, turn left.	ADPON [L] -	TF	N
To SALRU, turn left.	SALRU [L] -	TF	N
To VTK at or above 7000ft, turn right.	VTK [A070+; R] -	TF	N
To AKOMA at or above 11000ft, turn left.	AKOMA [A110+; L] -	TF	N
To AKMET.	AKMET -	TF	N
To AROSO.	AROSO	TF	N

Tabular Descriptions

Path Term	Waypoint Name	Fly-Over	Course °M(°T)	Distance (NM)	Turn Direction	Altitude	Speed Limit	Navigation Spec
CF	IBIXU	-	203(203.4)	4.0	-	A015+	-	RNAV1
TF	IBIVA	-	203(203.4)	3.0	L	A025+	-	RNAV1
TF	DUBOT	-	138(138.4)	7.0	L	A040+	-	RNAV1
TF	ADPON	-	052(052.4)	5.0	L	-	-	RNAV1
TF	SALRU	-	029(029.4)	6.0	L	-	-	RNAV1
TF	VTK	-	319(319.4)	10.0	R	A070+	-	RNAV1
TF	AKOMA	-	342(342.4)	21.0	L	A110+	-	RNAV1
TF	AKMET	-	307(307.4)	14.0	-	-	-	RNAV1
TF	AROSO	-	307(307.4)	24.0	-	-	-	RNAV1

Radio Communications Failure Procedure

1	SET TRANSPONDER TO MODE A/C CODE 7600
2	<p>COMMUNICATIONS FAILURE OCCURS IMMEDIATELY AFTER DEPARTURE:</p> <p>PROCEED DIRECT TO SAMKO HOLDING AREA (SHA) CLIMBING TO THE LAST ASSIGNED ALTITUDE, THEREAFTER REFER TO SINGAPORE AIP ON RADIO COMMUNICATIONS FAILURE PROCEDURE.</p>

STANDARD DEPARTURE CHART
RNAV (GNSS) -
INSTRUMENT (SID)

TWR 118.6 / 118.25
APP 120.3
124.05
ACC 133.25

TRANSITION ALTITUDE
11 000ft

D-ATIS AP ID-WSSS
128.6

SINGAPORE/Singapore Changi
RWY 02R
AROS0 DEPARTURES (RADAR)
AROS0 1C

ELEV, ALT IN FEET
BEARINGS, TRACKS AND
RADIALS ARE MAGNETIC
VAR 0°23'E (2020)

DISTANCES IN NM

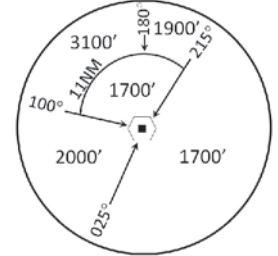

AROS0
02°08'46"N
103°24'21"E

307°
24

AKMET
01°53'55"N
103°43'39"E
A110

307°
14

AKOMA
01°45'22"N
103°54'43"E
A070

EXPECT RADAR vectors
to waypoint AKOMA

GENERAL INFORMATION

INITIAL CLIMB
3000FT

CAUTION: RWY 02R/20L NOT AVAILABLE FOR CIVIL USE UNTIL FURTHER ADVISED

NOTE: RADAR REQUIRED

NOTE: RNAV-1 NAVIGATION SPECIFICATION GNSS REQUIRED

NOTE: ACFT UNABLE TO FLY THE SID PROFILE SHALL INFORM ATC PRIOR TO DEPARTURE AND EXPECT RADAR VECTORING IF NECESSARY

NOTE: WHEN TAKEN OFF THE SID, AS INSTRUCTED BY ATC, REFER TO ENR 1.5, SECTION 3, PARAGRAPH 3.5 - FOR RWY 02R MINIMUM CLIMB GRADIENT

NOTE: REFER TO BACK PAGE FOR
- FORMAL AND TABULAR DESCRIPTIONS
- RADIO COM FAILURE PROCEDURES

PROCEDURE INFORMATION

SID SHALL NOT EXCEED IAS 230KTS UNTIL PASSING 4000FT AMSL AND NOT EXCEED IAS 250KTS UNTIL PASSING 10000FT AMSL.

CRUISING LEVELS WILL BE ISSUED AFTER TAKE-OFF BY SINGAPORE RADAR.

SID SHALL BE ON A MINIMUM CLIMB GRADIENT OF 5% UNTIL REACHING OR PASSING 2500FT, THEREAFTER 3.3%.

GND SPEED - KNOTS	75	100	150	200	250	300
5% V/V (fpm)	380	506	760	1013	1266	1519
3.3% V/V (fpm)	251	334	501	668	835	1003

DER(RWY02R)
01°21'22"N
104°00'51"E

TEKONG
DVOR/DME 116.5
VTK
01°24'55"N
104°01'20"E
60M

NOT TO SCALE

AROSO 1C (SID) RNAV GNSS RWY 02R - DESCRIPTIONS

Formal & Abbreviated Descriptions

Formal Description	Abbreviated Description	Path Terminator	Fly-Over required
Climb heading 023°, Gradient 5% to 2500ft, thence 3.3%. Expect radar vectors to waypoint AKOMA.	-	VA	N
To AKOMA at or above 7000ft.	AKOMA [A070+] -	DF	N
To AKMET at or above 11000ft.	AKMET [A110+] -	TF	N
To AROSO.	AROSO	TF	N

Tabular Descriptions

Path Term	Waypoint Name	Fly-Over	Course °M(°T)	Distance (NM)	Turn Direction	Altitude	Speed Limit	Navigation Spec
VA	-	-	023(023.4)	-	-	A030	-	-
DF	AKOMA	-	-	-	-	A070+	-	RNAV1
TF	AKMET	-	307(307.4)	14.0	-	A110+	-	RNAV1
TF	AROSO	-	307(307.4)	24.0	-	-	-	RNAV1

Radio Communications Failure Procedure

1	SET TRANSPONDER TO MODE A/C CODE 7600
2	<p>COMMUNICATIONS FAILURE OCCURS IMMEDIATELY AFTER DEPARTURE:</p> <p>PROCEED DIRECT TO NYLON HOLDING AREA (NHA) CLIMBING TO THE LAST ASSIGNED ALTITUDE, THEREAFTER REFER TO SINGAPORE AIP ON RADIO COMMUNICATIONS FAILURE PROCEDURE.</p>

STANDARD DEPARTURE CHART
RNAV (GNSS) -
INSTRUMENT (SID)

TWR 118.6 / 118.25
APP 120.3
124.05
ACC 133.25

TRANSITION ALTITUDE
11 000ft

D-ATIS AP ID-WSSS
128.6

SINGAPORE/Singapore Changi
RWY 20L
AROSO DEPARTURES
AROSO 1D

ELEV, ALT IN FEET
BEARINGS, TRACKS AND
RADIALS ARE MAGNETIC
VAR 0°23'E (2022)

NOT TO SCALE

DISTANCES IN NM

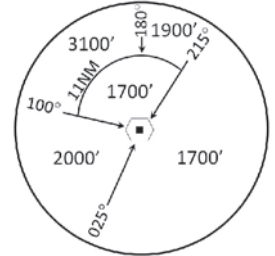

MSA 25 NM
from TEKONG DVOR

AROSO
02°08'46"N
103°24'21"E

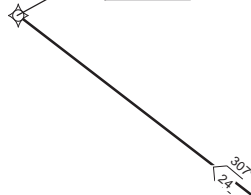

AKMET
01°53'55"N
103°43'39"E

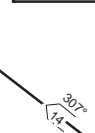

AKOMA
01°45'22"N
103°54'43"E

A110



TEKONG
DVOR/DME 116.5
VTK
01°24'55"N
104°01'20"E
60M

A070

DER(RWY 20L)
01°19'19"N
103°59'59"E

UKIBO
01°17'58"N
103°59'24"E

SALRU
01°17'01"N
104°08'02"E

POVEB
01°13'44"N
104°01'30"E

A025

ADPON
01°12'03"N
104°05'14"E

A040

GENERAL INFORMATION

INITIAL CLIMB
3000FT

CAUTION: RWY 02R/20L NOT AVAILABLE FOR CIVIL USE UNTIL FURTHER ADVISED

NOTE: RADAR REQUIRED

NOTE: RNAV-1 NAVIGATION SPECIFICATION GNSS REQUIRED

NOTE: ACFT UNABLE TO FLY THE SID PROFILE SHALL INFORM ATC PRIOR TO DEPARTURE AND EXPECT RADAR VECTORING IF NECESSARY

NOTE: WHEN TAKEN OFF THE SID, AS INSTRUCTED BY ATC, REFER TO ENR 1.5, SECTION 3, PARAGRAPH 3.4.3 - FOR RWY 20L MINIMUM CLIMB GRADIENT

NOTE: REFER TO BACK PAGE FOR
- FORMAL AND TABULAR DESCRIPTIONS
- RADIO COM FAILURE PROCEDURES

PROCEDURE INFORMATION

SID SHALL NOT EXCEED IAS 230KTS UNTIL PASSING 4000FT AMSL AND NOT EXCEED IAS 250KTS UNTIL PASSING 10000FT AMSL.

CRUISING LEVELS WILL BE ISSUED AFTER TAKE-OFF BY SINGAPORE RADAR.

SID SHALL BE ON A MINIMUM CLIMB GRADIENT OF 9% UNTIL REACHING OR PASSING 2500FT, THEREAFTER 3.3%.

GND SPEED - KNOTS	75	100	150	200	250	300
9% V/V (fpm)	684	911	1367	1823	2279	2734
3.3% V/V (fpm)	251	334	501	668	835	1003

AROSO 1D (SID) RNAV GNSS RWY 20L - DESCRIPTIONS**Formal & Abbreviated Descriptions**

Formal Description	Abbreviated Description	Path Terminator	Fly-Over required
To UKIBO on course 203°, turn left.	UKIBO [M203; L] -	CF	N
To POVEB at or above 2500ft, turn left.	POVEB [A025+; L] -	TF	N
To ADPON at or above 4000ft, turn left.	ADPON [A040+; L] -	TF	N
To SALRU, turn left.	SALRU [L] -	TF	N
To VTK at or above 7000ft, turn right.	VTK [A070+; R] -	TF	N
To AKOMA at or above 11000ft, turn left.	AKOMA [A110+; L] -	TF	N
To AKMET.	AKMET -	TF	N
To AROSO.	AROSO	TF	N

Tabular Descriptions

Path Term	Waypoint Name	Fly-Over	Course °M(°T)	Distance (NM)	Turn Direction	Altitude	Speed Limit	Navigation Spec
CF	UKIBO	-	203(203.4)	1.5	L	-	-	RNAV1
TF	POVEB	-	153(153.4)	5.0	L	A025+	-	RNAV1
TF	ADPON	-	114(114.4)	4.0	L	A040+	-	RNAV1
TF	SALRU	-	029(029.4)	6.0	L	-	-	RNAV1
TF	VTK	-	319(319.4)	10.0	R	A070+	-	RNAV1
TF	AKOMA	-	342(342.4)	21.0	L	A110+	-	RNAV1
TF	AKMET	-	307(307.4)	14.0	-	-	-	RNAV1
TF	AROSO	-	307(307.4)	24.0	-	-	-	RNAV1

Radio Communications Failure Procedure

1	SET TRANSPONDER TO MODE A/C CODE 7600
2	COMMUNICATIONS FAILURE OCCURS IMMEDIATELY AFTER DEPARTURE: PROCEED DIRECT TO SAMKO HOLDING AREA (SHA) CLIMBING TO THE LAST ASSIGNED ALTITUDE, THEREAFTER REFER TO SINGAPORE AIP ON RADIO COMMUNICATIONS FAILURE PROCEDURE.

STANDARD DEPARTURE CHART
RNAV (GNSS) -
INSTRUMENT (SID)

TWR 118.6 / 118.25
APP 120.3
124.05
ACC 133.25

TRANSITION ALTITUDE
11 000ft

D-ATIS AP ID-WSSS
128.6

SINGAPORE/Singapore Changi
RWY 02L
AROSO DEPARTURES
AROSO 3E

ELEV, ALT IN FEET
BEARINGS, TRACKS AND
RADIALS ARE MAGNETIC
VAR 0°23'E (2022)

DISTANCES IN NM

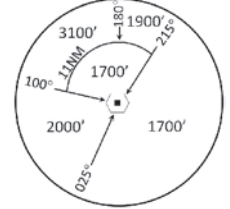

AROSO
02° 08' 46" N
103° 24' 21" E

307°
21

AKMET
01° 53' 55" N
103° 43' 39" E

A110

307°
14

AKOMA
01° 45' 22" N
103° 54' 43" E

A070

335°
14

ATRUM
01° 32' 56" N
104° 00' 57" E

A030

335°
3

MOLVO
01° 29' 55" N
104° 02' 27" E

A020

023°
8

DER (RWY 02L)
01° 23' 05" N
103° 59' 33" E

TEKONG
DVOR/DME 116.5
VTK
01° 24' 55" N
104° 01' 20" E
60M

GENERAL INFORMATION

INITIAL CLIMB
3000FT

CAUTION: RWY 02R/20L NOT AVAILABLE FOR CIVIL USE UNTIL FURTHER ADVISED

NOTE: RADAR REQUIRED

NOTE: RNAV-1 NAVIGATION SPECIFICATION GNSS REQUIRED

NOTE: ACFT UNABLE TO FLY THE SID PROFILE SHALL INFORM ATC PRIOR TO DEPARTURE AND EXPECT RADAR VECTORIZING IF NECESSARY

NOTE: WHEN TAKEN OFF THE SID, AS INSTRUCTED BY ATC, REFER TO ENR 1.5, SECTION 3, PARAGRAPH 3.2 [A] - FOR RWY 02L MINIMUM CLIMB GRADIENT

NOTE: REFER TO BACK PAGE FOR
- FORMAL AND TABULAR DESCRIPTIONS
- RADIO COM FAILURE PROCEDURES

PROCEDURE INFORMATION

SID SHALL NOT EXCEED IAS 230KTS UNTIL PASSING 4000FT AMSL AND NOT EXCEED IAS 250KTS UNTIL PASSING 10000FT AMSL.

CRUISING LEVELS WILL BE ISSUED AFTER TAKE-OFF BY SINGAPORE RADAR.

SID SHALL BE ON A MINIMUM CLIMB GRADIENT OF 5% UNTIL REACHING OR PASSING 2500FT, THEREAFTER 3.3%.

GND SPEED - KNOTS	75	100	150	200	250	300
5% V/V (fpm)	380	506	760	1013	1266	1519
3.3% V/V (fpm)	251	334	501	668	835	1003

NOT TO SCALE

31 OCT 2024

AROSO 3E (SID) RNAV GNSS RWY 02L - DESCRIPTIONS**Formal & Abbreviated Descriptions**

Formal Description	Abbreviated Description	Path Terminator	Fly-Over required
To MOLVO on course 023° at or above 2000ft, turn left.	MOLVO [M023; A020+; L] -	CF	N
To ATRUM.	ATRUM -	TF	N
To AKOMA at or above 7000ft, turn left.	AKOMA [A070+; L] -	TF	N
To AKMET at or above 11000ft.	AKMET [A110+] -	TF	N
To AROSO.	AROSO	TF	N

Tabular Descriptions

Path Term	Waypoint Name	Fly-Over	Course °M(°T)	Distance (NM)	Turn Direction	Altitude	Speed Limit	Navigation Spec
CF	MOLVO	-	023(023.4)	8.0	L	A020+	-	RNAV1
TF	ATRUM	-	333(333.4)	3.0	-	-	-	RNAV1
TF	AKOMA	-	333(333.4)	14.0	L	A070+	-	RNAV1
TF	AKMET	-	307(307.4)	14.0	-	A110+	-	RNAV1
TF	AROSO	-	307(307.4)	24.0	-	-	-	RNAV1

Radio Communications Failure Procedure

1	SET TRANSPONDER TO MODE A/C CODE 7600
2	COMMUNICATIONS FAILURE OCCURS IMMEDIATELY AFTER DEPARTURE: PROCEED DIRECT TO NYLON HOLDING AREA (NHA) CLIMBING TO THE LAST ASSIGNED ALTITUDE, THEREAFTER REFER TO SINGAPORE AIP ON RADIO COMMUNICATIONS FAILURE PROCEDURE.

STANDARD DEPARTURE CHART
RNAV (GNSS) -
INSTRUMENT (SID)

TWR 118.6 / 118.25
APP 120.3
124.05
ACC 133.25

TRANSITION ALTITUDE
11 000ft

D-ATIS AP ID-WSSS
128.6

SINGAPORE/Singapore Changi
RWY 20R
AROSO DEPARTURES
AROSO 5F

ELEV, ALT IN FEET
BEARINGS, TRACKS AND
RADIALS ARE MAGNETIC
VAR 0°23'E (2022)

NOT TO SCALE

DISTANCES IN NM

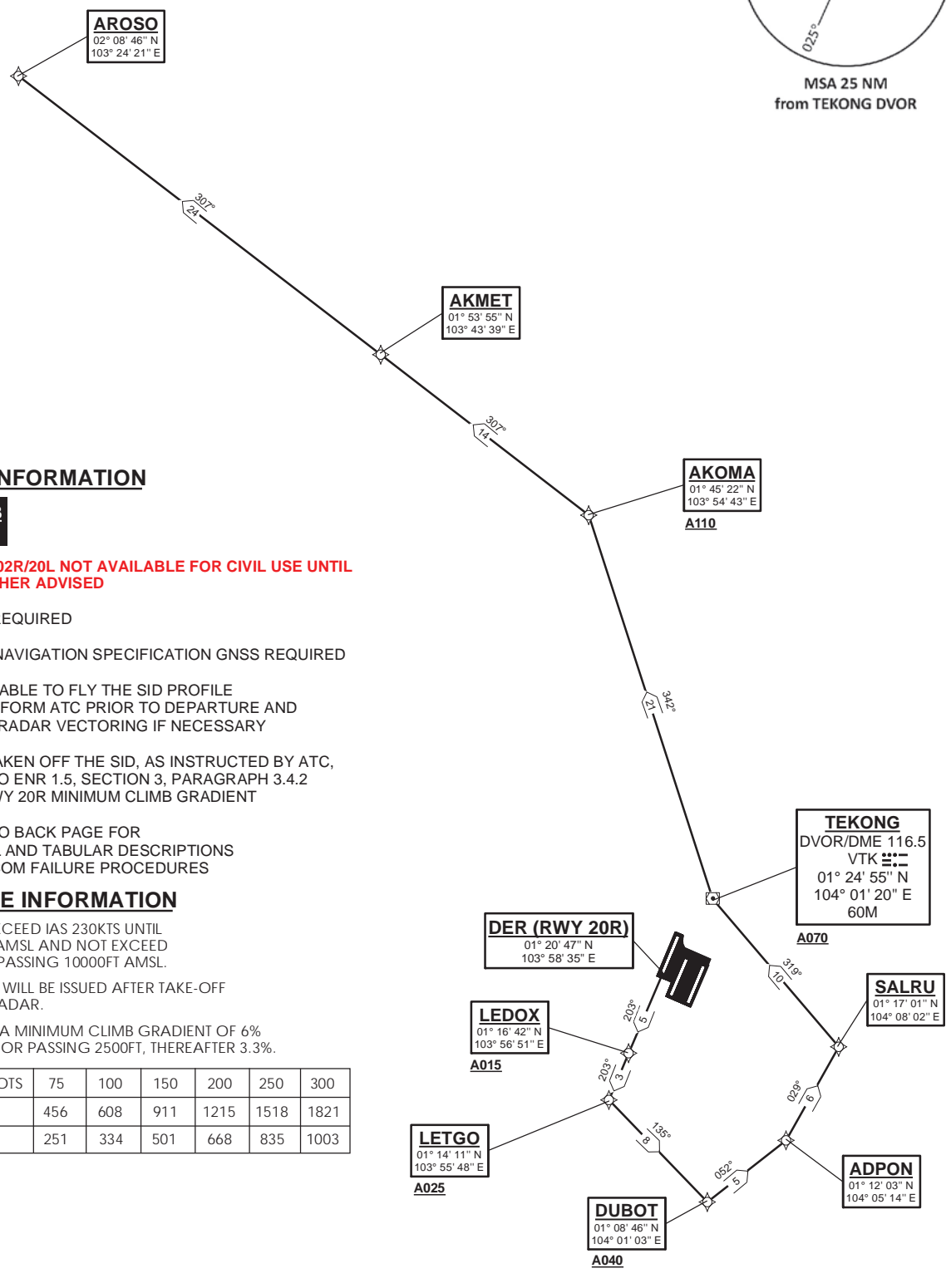
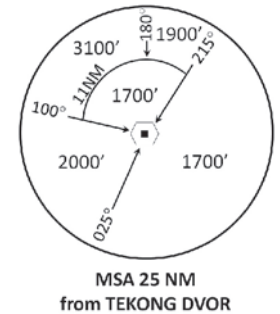

GENERAL INFORMATION

INITIAL CLIMB
3000FT

CAUTION: RWY 02R/20L NOT AVAILABLE FOR CIVIL USE UNTIL FURTHER ADVISED

NOTE: RADAR REQUIRED

NOTE: RNAV-1 NAVIGATION SPECIFICATION GNSS REQUIRED

NOTE: ACFT UNABLE TO FLY THE SID PROFILE SHALL INFORM ATC PRIOR TO DEPARTURE AND EXPECT RADAR VECTORING IF NECESSARY

NOTE: WHEN TAKEN OFF THE SID, AS INSTRUCTED BY ATC, REFER TO ENR 1.5, SECTION 3, PARAGRAPH 3.4.2 - FOR RWY 20R MINIMUM CLIMB GRADIENT

NOTE: REFER TO BACK PAGE FOR
- FORMAL AND TABULAR DESCRIPTIONS
- RADIO COM FAILURE PROCEDURES

PROCEDURE INFORMATION

SID SHALL NOT EXCEED IAS 230KTS UNTIL PASSING 4000FT AMSL AND NOT EXCEED IAS 250KTS UNTIL PASSING 10000FT AMSL.
CRUISING LEVELS WILL BE ISSUED AFTER TAKE-OFF BY SINGAPORE RADAR.
SID SHALL BE ON A MINIMUM CLIMB GRADIENT OF 6% UNTIL REACHING OR PASSING 2500FT, THEREAFTER 3.3%.

GND SPEED - KNOTS	75	100	150	200	250	300
6% V/V (fpm)	456	608	911	1215	1518	1821
3.3% V/V (fpm)	251	334	501	668	835	1003

AROSO 5F (SID) RNAV GNSS RWY 20R - DESCRIPTIONS

Formal & Abbreviated Descriptions

Formal Description	Abbreviated Description	Path Terminator	Fly-Over required
To LEDOX on course 203° at or above 1500ft.	LEDOX [M203; A015+] -	CF	N
To LETGO at or above 2500ft, turn left.	LETGO [A025+; L] -	TF	N
To DUBOT at or above 4000ft, turn left.	DUBOT [A040+; L] -	TF	N
To ADPON, turn left.	ADPON [L] -	TF	N
To SALRU, turn left.	SALRU [L] -	TF	N
To VTK at or above 7000ft, turn right.	VTK [A070+; R] -	TF	N
To AKOMA at or above 11000ft, turn left.	AKOMA [A110+; L] -	TF	N
To AKMET.	AKMET -	TF	N
To AROSO.	AROSO	TF	N

Tabular Descriptions

Path Term	Waypoint Name	Fly-Over	Course °M(°T)	Distance (NM)	Turn Direction	Altitude	Speed Limit	Navigation Spec
CF	LEDOX	-	203(203.4)	5.0	-	A015+	-	RNAV1
TF	LETGO	-	203(203.4)	3.0	L	A025+	-	RNAV1
TF	DUBOT	-	135(135.4)	8.0	L	A040+	-	RNAV1
TF	ADPON	-	052(052.4)	5.0	L	-	-	RNAV1
TF	SALRU	-	029(029.4)	6.0	L	-	-	RNAV1
TF	VTK	-	319(319.4)	10.0	R	A070+	-	RNAV1
TF	AKOMA	-	342(342.4)	21.0	L	A110+	-	RNAV1
TF	AKMET	-	307(307.4)	14.0	-	-	-	RNAV1
TF	AROSO	-	307(307.4)	24.0	-	-	-	RNAV1

Radio Communications Failure Procedure

1	SET TRANSPONDER TO MODE A/C CODE 7600
2	<p>COMMUNICATIONS FAILURE OCCURS IMMEDIATELY AFTER DEPARTURE:</p> <p>PROCEED DIRECT TO SAMKO HOLDING AREA (SHA) CLIMBING TO THE LAST ASSIGNED ALTITUDE, THEREAFTER REFER TO SINGAPORE AIP ON RADIO COMMUNICATIONS FAILURE PROCEDURE.</p>

STANDARD DEPARTURE CHART RNAV (GNSS) - INSTRUMENT (SID)

SINGAPORE/Singapore Changi RWY 02C DODSO DEPARTURES DODSO 1A

TWR 118.6 / 118.25 APP 120.3 ACC 134.2	TRANSITION ALTITUDE 11 000ft	D-ATIS AP ID-WSSS 128.6
--	---------------------------------	----------------------------

PROCEDURE INFORMATION

SID SHALL NOT EXCEED IAS 230KTS UNTIL PASSING 4000FT AMSL AND NOT EXCEED IAS 250KTS UNTIL PASSING 10000FT AMSL. CRUISING LEVELS WILL BE ISSUED AFTER TAKE-OFF BY SINGAPORE RADAR.
SID SHALL BE ON A MINIMUM CLIMB GRADIENT OF 5% UNTIL REACHING OR PASSING 2500FT, THEREAFTER 3.3%.

GND SPEED - KNOTS	75	100	150	200	250	300
5% V/V (fpm)	380	506	760	1013	1266	1519
3.3% V/V (fpm)	251	334	501	668	835	1003

TEKONG
DVOR/DME 116.5
VTK ---
01° 24' 55"N
104° 01' 20" E
60m

MOXIB
01° 29' 33"N
104° 03' 15" E
A020

DER (RWY 02C)
01° 21' 45.00"N
103° 59' 57.00" E

EMRIX
01° 26' 06"N
104° 10' 40" E
A040

HOSBA
01° 19' 48"N
104° 24' 18" E
A070

VEBMA
01° 20' 30"N
104° 53' 32" E

TOMAN
01° 21' 47"N
105° 47' 17" E

DODSO
01° 22' 25"N
106° 14' 02" E

GENERAL INFORMATION

INITIAL CLIMB
3000FT

CAUTION: RWY 02R/20L NOT AVAILABLE FOR CIVIL USE UNTIL FURTHER ADVISED

- NOTE:** RADAR REQUIRED
- NOTE:** RNAV-1 NAVIGATION SPECIFICATION GNSS REQUIRED
- NOTE:** CLOSE-IN OBSTACLES (AIRCRAFT UP TO 80FT) EXIST ON TAXIWAYS WEST OF RUNWAY 02C

NOTE: ACFT UNABLE TO FLY THE SID PROFILE SHALL INFORM ATC PRIOR TO DEPARTURE AND TO EXPECT RADAR VECTORED, IF NECESSARY

NOTE: WHEN TAKEN OFF THE SID, AS INSTRUCTED BY ATC, REFER TO ENR 1.5, SECTION 3, PARAGRAPH 3.3 [A] - FOR RWY 02C MINIMUM CLIMB GRADIENT

NOTE: REFER TO BACK PAGE FOR - FORMAL AND TABULAR DESCRIPTIONS - RADIO COM FAILURE PROCEDURES

ELEV, ALT IN FEET

BEARINGS, TRACKS AND RADIALS ARE MAGNETIC VAR 0°23'E (2020)

DISTANCES IN NM

MSA 25 NM
from TEKONG DVOR

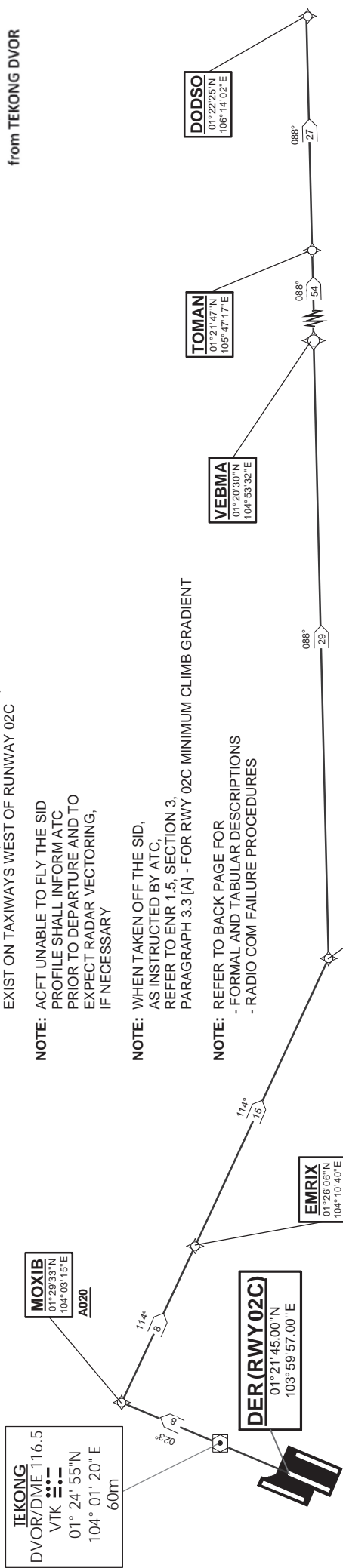
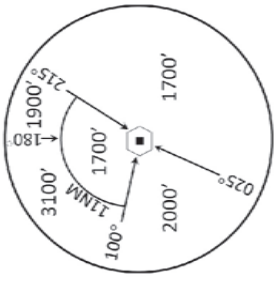

NOT TO SCALE

DODSO 1A (SID) RNAV GNSS RWY 02C - DESCRIPTIONS**Formal & Abbreviated Descriptions**

Formal Description	Abbreviated Description	Path Terminator	Fly-Over required
To MOXIB on course 203° at or above 2000ft, turn right.	MOXIB [M203; A020+; R] -	CF	N
To EMRIX at or above 4000ft.	EMRIX [A040+] -	TF	N
To HOSBA at or above 7000ft, turn left.	HOSBA [A070+; L] -	TF	N
To VEBMA.	VEBMA -	TF	N
To TOMAN.	TOMAN -	TF	N
To DODSO.	DODSO	TF	N

Tabular Descriptions

Path Term	Waypoint Name	Fly-Over	Course °M(°T)	Distance (NM)	Turn Direction	Altitude	Speed Limit	Navigation Spec
CF	MOXIB	-	023(023.4)	8.0	R	A020+	-	RNAV1
TF	EMRIX	-	114(114.4)	8.0	-	A040+	-	RNAV1
TF	HOSBA	-	114(114.4)	15.0	L	A070+	-	RNAV1
TF	VEBMA	-	088(088.4)	29.0	-	-	-	RNAV1
TF	TOMAN	-	088(088.4)	54.0	-	-	-	RNAV1
TF	DODSO	-	088(088.4)	27.0	-	-	-	RNAV1

Radio Communications Failure Procedure

1	SET TRANSPONDER TO MODE A/C CODE 7600
2	COMMUNICATIONS FAILURE OCCURS IMMEDIATELY AFTER DEPARTURE: PROCEED DIRECT TO NYLON HOLDING AREA (NHA) CLIMBING TO THE LAST ASSIGNED ALTITUDE, THEREAFTER REFER TO SINGAPORE AIP ON RADIO COMMUNICATIONS FAILURE PROCEDURE.

STANDARD DEPARTURE CHART
RNAV (GNSS) -
INSTRUMENT (SID)

TWR 118.6 / 118.25
APP 120.3
ACC 134.2

TRANSITION ALTITUDE
11 000ft

D-ATIS AP ID-WSSS
128.6

SINGAPORE/Singapore Changi
RWY 20C
DODSO DEPARTURES
DODSO 1B

GENERAL INFORMATION

INITIAL CLIMB
3000FT

CAUTION: RWY 02R/20L NOT AVAILABLE FOR CIVIL USE UNTIL FURTHER ADVISED

- NOTE:** RADAR REQUIRED
- NOTE:** RNAV-1 NAVIGATION SPECIFICATION GNSS REQUIRED
- NOTE:** ACFT UNABLE TO FLY THE SID PROFILE SHALL INFORM ATC PRIOR TO DEPARTURE AND EXPECT RADAR VECTORED IF NECESSARY
- NOTE:** WHEN TAKEN OFF THE SID, AS INSTRUCTED BY ATC, REFER TO ENR 1.5, SECTION 3, PARAGRAPH 3.4.1 - FOR RWY 20C MINIMUM CLIMB GRADIENT
- NOTE:** REFER TO BACK PAGE FOR
 - FORMAL AND TABULAR DESCRIPTIONS
 - RADIO COM FAILURE PROCEDURES

PROCEDURE INFORMATION

SID SHALL NOT EXCEED IAS 230KTS UNTIL PASSING 4000FT AMSL AND NOT EXCEED IAS 250KTS UNTIL PASSING 10000FT AMSL. CRUISING LEVELS WILL BE ISSUED AFTER TAKE-OFF BY SINGAPORE RADAR.

SID SHALL BE ON A MINIMUM CLIMB GRADIENT OF 7% UNTIL REACHING OR PASSING 2500FT, THEREAFTER 3.3%.

GND SPEED - KNOTS	75	100	150	200	250	300
7% V/V (fpm)	532	709	1063	1418	1772	2127
3.3% V/V (fpm)	251	334	501	668	835	1003

ELEV, ALT IN FEET

BEARINGS, TRACKS AND RADIALS ARE MAGNETIC VAR 0°23'E (2020)

DISTANCES IN NM

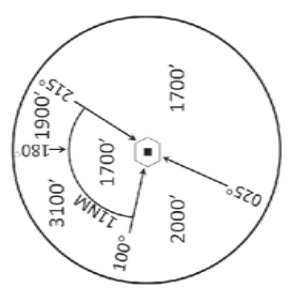

MSA 25 NM
from TEKONG DVOR

TEKONG
DVOR/DME 116.5
VTK
01° 24' 55"N
104° 01' 20"E
60m

DER (RWY 20C)
01° 19' 42.00"N
103° 59' 05.00"E

IBIXU
01° 16' 21"N
103° 57' 40"E
A015

IBIVA
01° 13' 51"N
103° 56' 37"E
A025

DUBOT
01° 08' 46"N
104° 01' 03"E
A040

ERVIV
01° 04' 45"N
104° 10' 13"E
A060

TOMAN
01° 21' 47"N
105° 47' 17"E

VEBMA
01° 20' 30"N
104° 53' 32"E

GOTGA
01° 20' 13"N
104° 42' 00"E

SEBVO
01° 12' 58"N
104° 34' 48"E
A090

MUMDU
01° 05' 21"N
104° 27' 14"E

DODSO
01° 22' 25"N
106° 14' 02"E

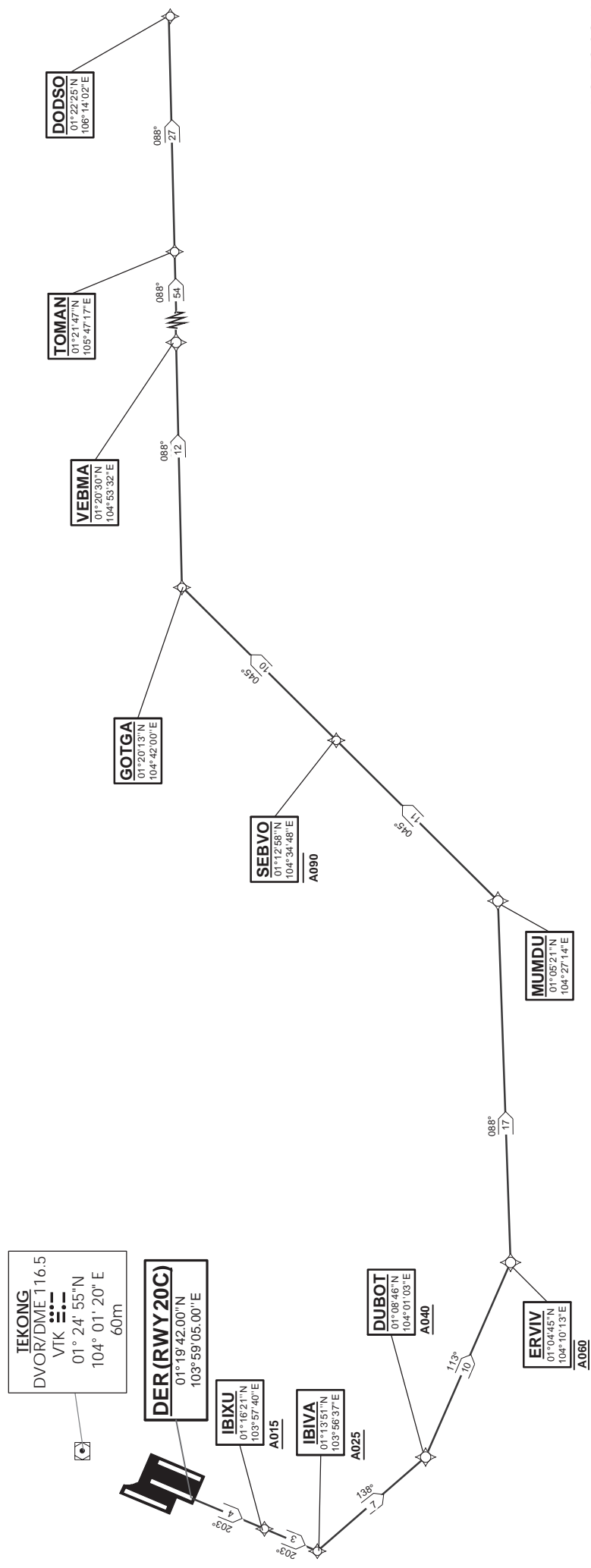

NOT TO SCALE

DODSO 1B (SID) RNAV GNSS RWY 20C - DESCRIPTIONS

Formal & Abbreviated Descriptions

Formal Description	Abbreviated Description	Path Terminator	Fly-Over required
To IBIXU on course 203° at or above 1500ft.	IBIXU [M203; A015+] -	CF	N
To IBIVA at or above 2500ft, turn left.	IBIVA [A025+; L] -	TF	N
To DUBOT at or above 4000ft, turn left.	DUBOT [A040+; L] -	TF	N
To ERVIV at 6000ft, turn left.	ERVIV [@A060; L] -	TF	N
To MUMDU, turn left.	MUMDU [L] -	TF	N
To SEBVO at or below 9000ft.	SEBVO [A090-] -	TF	N
To GOTGA, turn right.	GOTGA [R] -	TF	N
To VEBMA.	VEBMA -	TF	N
To TOMAN.	TOMAN -	TF	N
To DODSO.	DODSO	TF	N

Tabular Descriptions

Path Term	Waypoint Name	Fly-Over	Course °M(°T)	Distance (NM)	Turn Direction	Altitude	Speed Limit	Navigation Spec
CF	IBIXU	-	203(203.4)	4.0	-	A015+	-	RNAV1
TF	IBIVA	-	203(203.4)	3.0	L	A025+	-	RNAV1
TF	DUBOT	-	138(138.4)	7.0	L	A040+	-	RNAV1
TF	ERVIV	-	113(113.4)	10.0	L	@A060	-	RNAV1
TF	MUMDU	-	088(088.4)	17.0	L	-	-	RNAV1
TF	SEBVO	-	045(045.4)	11.0	-	A090-	-	RNAV1
TF	GOTGA	-	045(045.4)	10.0	R	-	-	RNAV1
TF	VEBMA	-	088(088.4)	12.0	-	-	-	RNAV1
TF	TOMAN	-	088(088.4)	54.0	-	-	-	RNAV1
TF	DODSO	-	088(088.4)	27.0	-	-	-	RNAV1

Radio Communications Failure Procedure

1	SET TRANSPONDER TO MODE A/C CODE 7600
2	<p>COMMUNICATIONS FAILURE OCCURS IMMEDIATELY AFTER DEPARTURE:</p> <p>PROCEED DIRECT TO SAMKO HOLDING AREA (SHA) CLIMBING TO THE LAST ASSIGNED ALTITUDE, THEREAFTER REFER TO SINGAPORE AIP ON RADIO COMMUNICATIONS FAILURE PROCEDURE.</p>

STANDARD DEPARTURE CHART
RNAV (GNSS) -
INSTRUMENT (SID)

TWR 118.6 / 118.25
APP 120.3
124.05
ACC 134.2

TRANSITION ALTITUDE
11 000ft

D-ATIS AP ID-WSSS
128.6

SINGAPORE/Singapore Changi
RWY 02R
DODSO DEPARTURES (RADAR)
DODSO 1C

PROCEDURE INFORMATION

SID SHALL NOT EXCEED IAS 230KTS UNTIL PASSING 4000FT AMSL AND NOT EXCEED IAS 250KTS UNTIL PASSING 10000FT AMSL.
CRUISING LEVELS WILL BE ISSUED AFTER TAKE-OFF BY SINGAPORE RADAR.
SID SHALL BE ON A MINIMUM CLIMB GRADIENT OF 5% UNTIL REACHING OR PASSING 2500FT, THEREAFTER 3.3%.

GND SPEED - KNOTS	75	100	150	200	250	300
5% V/V (fpm)	380	506	760	1013	1266	1519
3.3% V/V (fpm)	251	334	501	668	835	1003

TEKONG
DVOR/DME 116.5
VTK 
01° 24' 55"N
104° 01' 20" E
60m

GENERAL INFORMATION

INITIAL CLIMB
3000FT

CAUTION: RWY 02R/20L NOT AVAILABLE FOR CIVIL USE UNTIL FURTHER ADVISED

- NOTE:** RADAR REQUIRED
- NOTE:** RNAV-1 NAVIGATION SPECIFICATION GNSS REQUIRED
- NOTE:** ACFT UNABLE TO FLY THE SID PROFILE SHALL INFORM ATC PRIOR TO DEPARTURE AND EXPECT RADAR VECTORED IF NECESSARY

NOTE: WHEN TAKEN OFF THE SID, AS INSTRUCTED BY ATC, REFER TO ENR 1.5, SECTION 3, PARAGRAPH 3.5
- FOR RWY 02R MINIMUM CLIMB GRADIENT

NOTE: REFER TO BACK PAGE FOR
- FORMAL AND TABULAR DESCRIPTIONS
- RADIO COM FAILURE PROCEDURES

ELEV, ALT IN FEET

BEARINGS, TRACKS AND RADIALS ARE MAGNETIC
VAR 0°23'E (2020)

DISTANCES IN NM

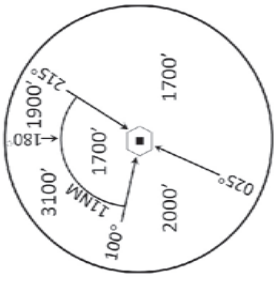

MSA 25 NM
from TEKONG DVOR

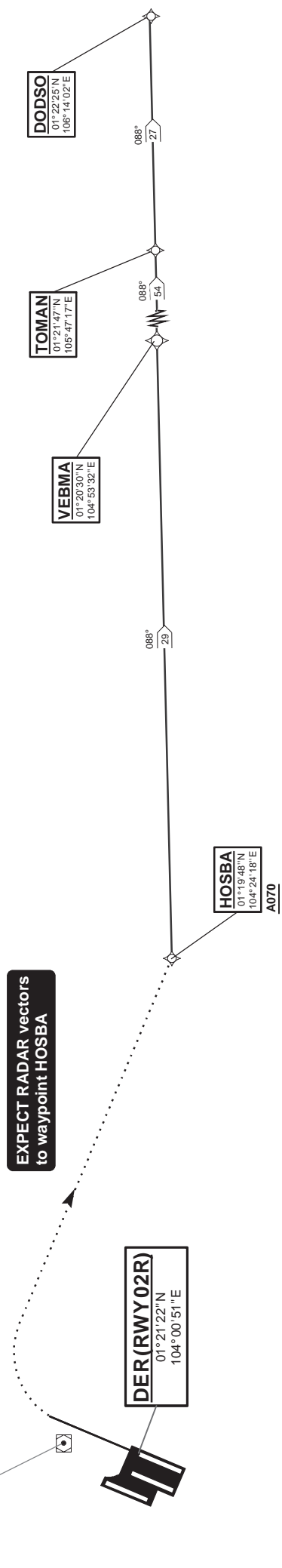

NOT TO SCALE

31 OCT 2024

DODSO 1C (SID) RNAV GNSS RWY 02R - DESCRIPTIONS**Formal & Abbreviated Descriptions**

Formal Description	Abbreviated Description	Path Terminator	Fly-Over required
Climb heading 023°, Gradient 5% to 2500ft, thence 3.3%. Expect radar vectors to waypoint HOSBA.	-	VA	N
To HOSBA at or above 7000ft.	HOSBA [A070+] -	DF	N
To VEBMA.	VEBMA -	TF	N
To TOMAN.	TOMAN -	TF	N
To DODSO.	DODSO	TF	N

Tabular Descriptions

Path Term	Waypoint Name	Fly-Over	Course °M(°T)	Distance (NM)	Turn Direction	Altitude	Speed Limit	Navigation Spec
VA	-	-	023(023.4)	-	-	A030	-	RNAV1
DF	HOSBA	-	-	-	-	A070+	-	RNAV1
TF	VEBMA	-	088(088.4)	29.0	-	-	-	RNAV1
TF	TOMAN	-	088(088.4)	54.0	-	-	-	RNAV1
TF	DODSO	-	088(088.4)	27.0	-	-	-	RNAV1

Radio Communications Failure Procedure

1	SET TRANSPONDER TO MODE A/C CODE 7600
2	COMMUNICATIONS FAILURE OCCURS IMMEDIATELY AFTER DEPARTURE: PROCEED DIRECT TO NYLON HOLDING AREA (NHA) CLIMBING TO THE LAST ASSIGNED ALTITUDE, THEREAFTER REFER TO SINGAPORE AIP ON RADIO COMMUNICATIONS FAILURE PROCEDURE.

STANDARD DEPARTURE CHART
RNAV (GNSS) -
INSTRUMENT (SID)

SINGAPORE/Singapore Changi
RWY 20L
DODSO DEPARTURES
DODSO 1D

D-ATIS AP ID-WSSS
128.6

TRANSITION ALTITUDE
11 000ft

TWR 118.6 / 118.25
APP 120.3
124.05
ACC 134.2

GENERAL INFORMATION

INITIAL CLIMB
3000FT

CAUTION: RWY 02R/20L NOT AVAILABLE FOR CIVIL USE UNTIL FURTHER ADVISED

- NOTE:** RADAR REQUIRED
- NOTE:** RNAV-1 NAVIGATION SPECIFICATION GNSS REQUIRED
- NOTE:** ACFT UNABLE TO FLY THE SID PROFILE SHALL INFORM ATC PRIOR TO DEPARTURE AND EXPECT RADAR VECTORING IF NECESSARY
- NOTE:** WHEN TAKEN OFF THE SID, AS INSTRUCTED BY ATC, REFER TO ENR 1.5, SECTION 3, PARAGRAPH 3.4.3 - FOR RWY 20L MINIMUM CLIMB GRADIENT
- NOTE:** REFER TO BACK PAGE FOR
 - FORMAL AND TABULAR DESCRIPTIONS
 - RADIO COM FAILURE PROCEDURES

TEKONG
DVOR/DME 116.5
VTK
01° 24' 55"N
104° 01' 20" E
60m

DER (RWY 20L)
01° 19' 19"N
103° 59' 59"E

UKIBO
01° 17' 58"N
103° 59' 24"E

DUBOT
01° 08' 46"N
104° 01' 03"E
A040

ERVIV
01° 04' 45"N
104° 10' 13"E
A060

PROCEDURE INFORMATION

SID SHALL NOT EXCEED IAS 230KTS UNTIL PASSING 4000FT AMSL AND NOT EXCEED IAS 250KTS UNTIL PASSING 10000FT AMSL.
CRUISING LEVELS WILL BE ISSUED AFTER TAKE-OFF BY SINGAPORE RADAR.

SID SHALL BE ON A MINIMUM CLIMB GRADIENT OF 9% UNTIL REACHING OR PASSING 2500FT, THEREAFTER 3.3%.

GND SPEED - KNOTS	75	100	150	200	250	300
9% V/V (fpm)	684	911	1367	1823	2279	2734
3.3% V/V (fpm)	251	334	501	668	835	1003

ELEV, ALT IN FEET

BEARINGS, TRACKS AND RADIALS ARE MAGNETIC
VAR 0°23'E (2020)

DISTANCES IN NM

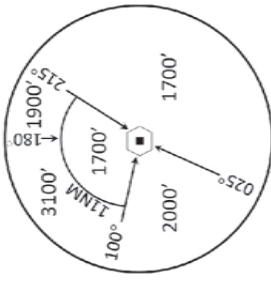

MSA 25 NM
from TEKONG DVOR

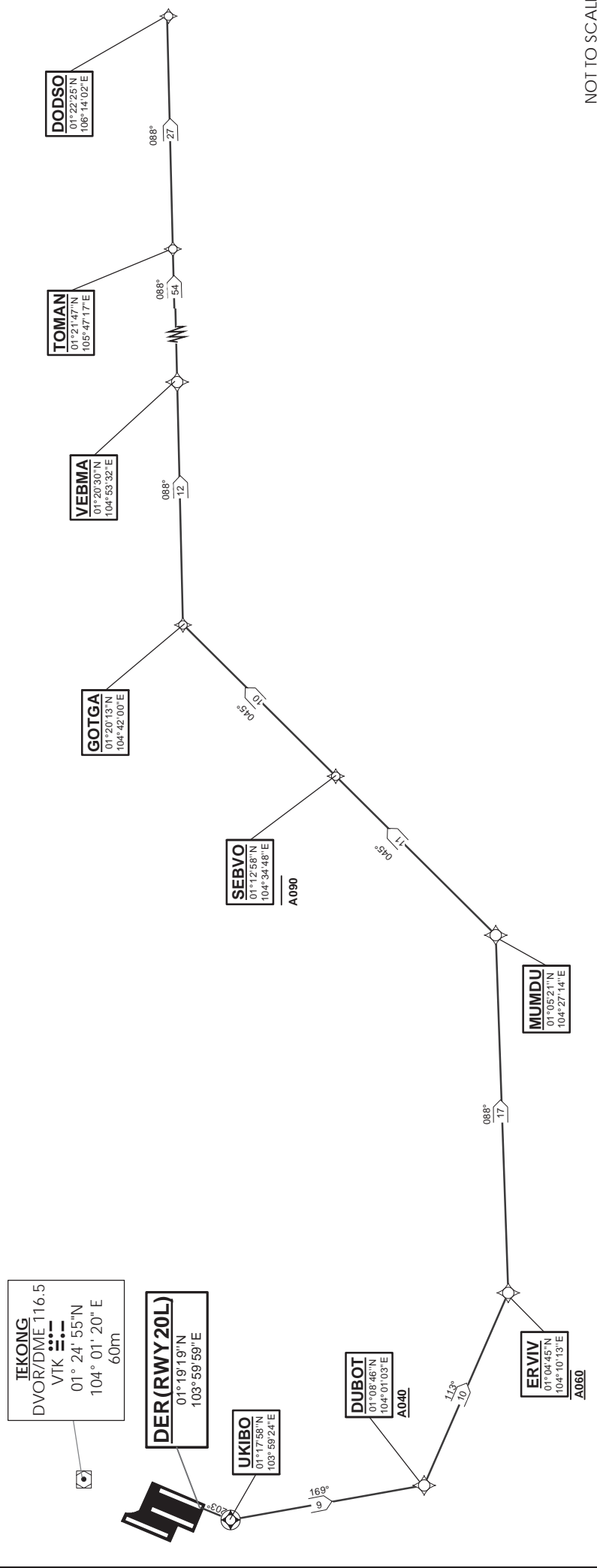

NOT TO SCALE

DODSO 1D (SID) RNAV GNSS RWY 20L - DESCRIPTIONS

Formal & Abbreviated Descriptions

Formal Description	Abbreviated Description	Path Terminator	Fly-Over required
To UKIBO on course 203°, turn left.	UKIBO [M203; L] -	CF	N
To DUBOT at or above 4000ft, turn left.	DUBOT [A040+; L] -	TF	N
To ERVIV at 6000ft, turn left.	ERVIV [@A060; L] -	TF	N
To MUMDU, turn left.	MUMDU [L] -	TF	N
To SEBVO at or below 9000ft.	SEBVO [A090-] -	TF	N
To GOTGA, turn right.	GOTGA [R] -	TF	N
To VEBMA.	VEBMA -	TF	N
To TOMAN.	TOMAN -	TF	N
To DODSO.	DODSO	TF	N

Tabular Descriptions

Path Term	Waypoint Name	Fly-Over	Course °M(°T)	Distance (NM)	Turn Direction	Altitude	Speed Limit	Navigation Spec
CF	UKIBO	Y	203(203.4)	1.5	L	-	-	RNAV1
TF	DUBOT	-	169(169.4)	9.0	L	A040+	-	RNAV1
TF	ERVIV	-	113(113.4)	10.0	L	@A060	-	RNAV1
TF	MUMDU	-	088(088.4)	17.0	L	-	-	RNAV1
TF	SEBVO	-	045(045.4)	11.0	-	A090-	-	RNAV1
TF	GOTGA	-	045(045.4)	10.0	R	-	-	RNAV1
TF	VEBMA	-	088(088.4)	12.0	-	-	-	RNAV1
TF	TOMAN	-	088(088.4)	54.0	-	-	-	RNAV1
TF	DODSO	-	088(088.4)	27.0	-	-	-	RNAV1

Radio Communications Failure Procedure

1	SET TRANSPONDER TO MODE A/C CODE 7600
2	COMMUNICATIONS FAILURE OCCURS IMMEDIATELY AFTER DEPARTURE: PROCEED DIRECT TO SAMKO HOLDING AREA (SHA) CLIMBING TO THE LAST ASSIGNED ALTITUDE, THEREAFTER REFER TO SINGAPORE AIP ON RADIO COMMUNICATIONS FAILURE PROCEDURE.

STANDARD DEPARTURE CHART
RNAV (GNSS) -
INSTRUMENT (SID)

SINGAPORE/Singapore Changi
RWY 02L
DODSO DEPARTURES
DODSO 1E

TWR 118.6 / 118.25	D-ATIS AP ID-WSSSS 128.6
APP 120.3	TRANSITION ALTITUDE 11 000ft
ACC 124.05	
ACC 134.2	

PROCEDURE INFORMATION

SID SHALL NOT EXCEED IAS 230KTS UNTIL PASSING 4000FT AMSL AND NOT EXCEED IAS 250KTS UNTIL PASSING 10000FT AMSL. CRUISING LEVELS WILL BE ISSUED AFTER TAKE-OFF BY SINGAPORE RADAR.

SID SHALL BE ON A MINIMUM CLIMB GRADIENT OF 5% UNTIL REACHING OR PASSING 2500FT, THEREAFTER 3.3%.

GND SPEED - KNOTS	75	100	150	200	250	300
5% V/V (fpm)	380	506	760	1013	1266	1519
3.3% V/V (fpm)	251	334	501	668	835	1003

GENERAL INFORMATION

INITIAL CLIMB
3000FT

CAUTION: RWY 02R/20L NOT AVAILABLE FOR CIVIL USE UNTIL FURTHER ADVISED

- NOTE:** RADAR REQUIRED
- NOTE:** RNAV-1 NAVIGATION SPECIFICATION GNSS REQUIRED
- NOTE:** ACFT UNABLE TO FLY THE SID PROFILE SHALL INFORM ATC PRIOR TO DEPARTURE AND EXPECT RADAR VECTORING IF NECESSARY

NOTE: WHEN TAKEN OFF THE SID, AS INSTRUCTED BY ATC, REFER TO ENR 1.5, SECTION 3, PARAGRAPH 3.2 [A]
- FOR RWY 02L MINIMUM CLIMB GRADIENT

NOTE: REFER TO BACK PAGE FOR
- FORMAL AND TABULAR DESCRIPTIONS
- RADIO COM FAILURE PROCEDURES

ELEV, ALT IN FEET
BEARINGS, TRACKS AND RADIALS ARE MAGNETIC VAR 0°23'E (2020)
DISTANCES IN NM

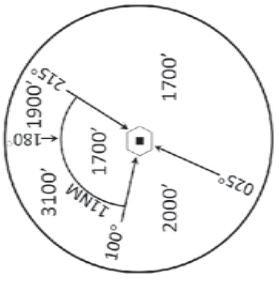

MSA 25 NM
from TEKONG DVOR

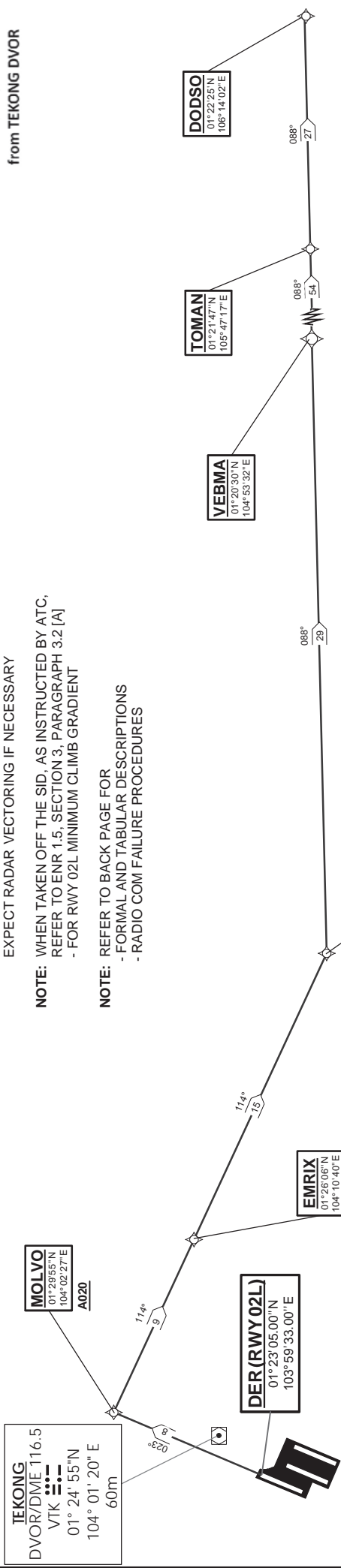

NOT TO SCALE

DODSO 1E (SID) RNAV GNSS RWY 02L - DESCRIPTIONS

Formal & Abbreviated Descriptions

Formal Description	Abbreviated Description	Path Terminator	Fly-Over required
To MOLVO on course 023° at or above 2000ft, turn right.	MOLVO [M023; A020+; R] -	CF	N
To EMRIX at or above 4000ft.	EMRIX [A040+] -	TF	N
To HOSBA at or above 7000ft, turn left.	HOSBA [A070+; L] -	TF	N
To VEBMA.	VEBMA -	TF	N
To TOMAN.	TOMAN -	TF	N
To DODSO.	DODSO	TF	N

Tabular Descriptions

Path Term	Waypoint Name	Fly-Over	Course °M(°T)	Distance (NM)	Turn Direction	Altitude	Speed Limit	Navigation Spec
CF	MOLVO	-	023(023.4)	8.0	R	A020+	-	RNAV1
TF	EMRIX	-	114(114.4)	9.0	-	A040+	-	RNAV1
TF	HOSBA	-	114(114.4)	15.0	L	A070+	-	RNAV1
TF	VEBMA	-	088(088.4)	29.0	-	-	-	RNAV1
TF	TOMAN	-	088(088.4)	54.0	-	-	-	RNAV1
TF	DODSO	-	088(088.4)	27.0	-	-	-	RNAV1

Radio Communications Failure Procedure

1	SET TRANSPONDER TO MODE A/C CODE 7600
2	<p>COMMUNICATIONS FAILURE OCCURS IMMEDIATELY AFTER DEPARTURE:</p> <p>PROCEED DIRECT TO NYLON HOLDING AREA (NHA) CLIMBING TO THE LAST ASSIGNED ALTITUDE, THEREAFTER REFER TO SINGAPORE AIP ON RADIO COMMUNICATIONS FAILURE PROCEDURE.</p>

STANDARD DEPARTURE CHART
RNAV (GNSS) -
INSTRUMENT (SID)

TWR 118.6 / 118.25
APP 120.3
124.05
ACC 134.2

TRANSITION ALTITUDE
11 000ft

D-ATIS AP ID-WSSS
128.6

SINGAPORE/Singapore Changi
RWY 20R
DODSO DEPARTURES
DODSO 1F

GENERAL INFORMATION

INITIAL CLIMB
3000FT

CAUTION: RWY 02R/20L NOT AVAILABLE FOR CIVIL USE UNTIL FURTHER ADVISED

- NOTE:** RADAR REQUIRED
- NOTE:** RNAV-1 NAVIGATION SPECIFICATION GNSS REQUIRED
- NOTE:** ACFT UNABLE TO FLY THE SID PROFILE SHALL INFORM ATC PRIOR TO DEPARTURE AND EXPECT RADAR VECTORED IF NECESSARY
- NOTE:** WHEN TAKEN OFF THE SID, AS INSTRUCTED BY ATC, REFER TO ENR 1.5, SECTION 3, PARAGRAPH 3.4.2 - FOR RWY 20R MINIMUM CLIMB GRADIENT
- NOTE:** REFER TO BACK PAGE FOR
 - FORMAL AND TABULAR DESCRIPTIONS
 - RADIO COM FAILURE PROCEDURES

PROCEDURE INFORMATION

SID SHALL NOT EXCEED IAS 230KTS UNTIL PASSING 4000FT AMSL AND NOT EXCEED IAS 250KTS UNTIL PASSING 10000FT AMSL.

CRUISING LEVELS WILL BE ISSUED AFTER TAKE-OFF BY SINGAPORE RADAR.

SID SHALL BE ON A MINIMUM CLIMB GRADIENT OF 6% UNTIL REACHING OR PASSING 2500FT, THEREAFTER 3.3%.

GND SPEED - KNOTS	75	100	150	200	250	300
6% V/V (fpm)	456	608	911	1215	1518	1821
3.3% V/V (fpm)	251	334	501	668	835	1003

ELEV, ALT IN FEET

BEARINGS, TRACKS AND RADIALS ARE MAGNETIC VAR 0°23'E (2020)

DISTANCES IN NM

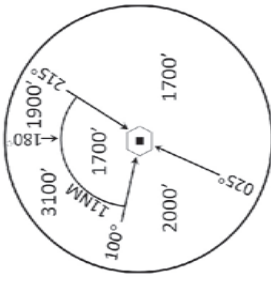

MSA 25 NM
from TEKONG DVOR

TEKONG
DVOR/DME 116.5
VTK
01° 24' 55"N
104° 01' 20"E
60m

DER (RWY 20R)
01° 20' 47.00"N
103° 58' 35.00"E

LEDUX
01° 16' 42"N
103° 56' 51"E
A015

LETGO
01° 14' 11"N
103° 55' 48"E
A025

DUBOT
01° 08' 46"N
104° 01' 03"E
A040

ERVIV
01° 04' 45"N
104° 10' 13"E
A060

VEBMA
01° 20' 30"N
104° 53' 32"E

TOMAN
01° 21' 47"N
105° 47' 17"E

DODSO
01° 22' 25"N
106° 14' 02"E

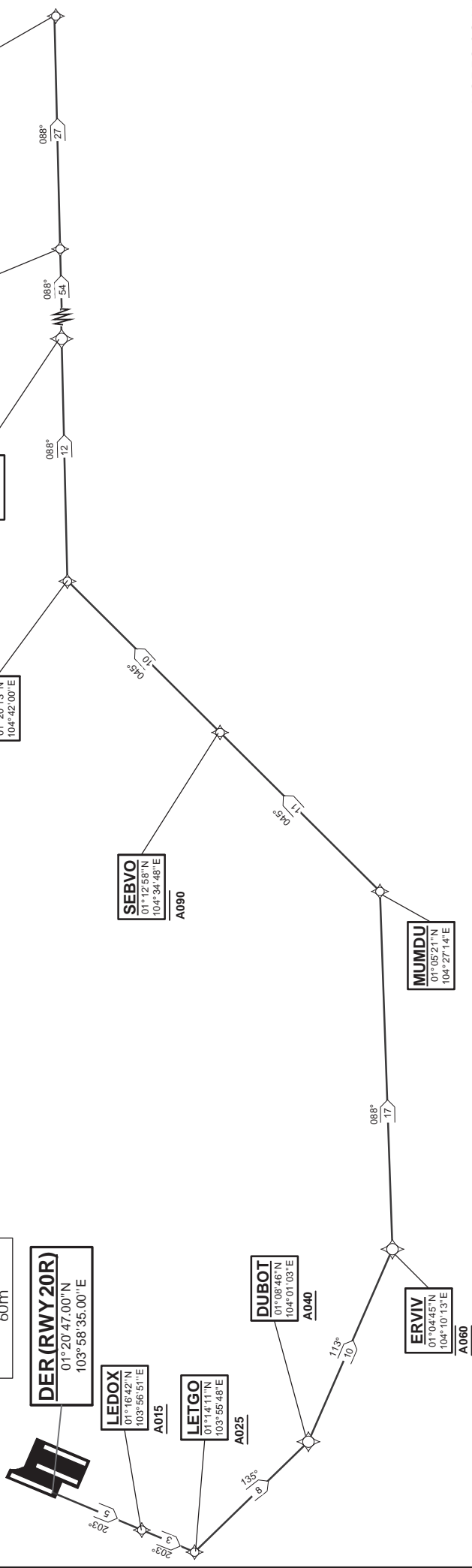

NOT TO SCALE

31 OCT 2024

DODSO 1F (SID) RNAV GNSS RWY 20R - DESCRIPTIONS**Formal & Abbreviated Descriptions**

Formal Description	Abbreviated Description	Path Terminator	Fly-Over required
To LEDOX on course 203° at or above 1500ft.	LEDOX [M203; A015+] -	CF	N
To LETGO at or above 2500ft, turn left.	LETGO [A025+; L] -	TF	N
To DUBOT at or above 4000ft, turn left.	DUBOT [A040+; L] -	TF	N
To ERVIV at 6000ft, turn left.	ERVIV [@A060; L] -	TF	N
To MUMDU, turn left.	MUMDU [L] -	TF	N
To SEBVO at or below 9000ft.	SEBVO [A090-] -	TF	N
To GOTGA, turn right.	GOTGA [R] -	TF	N
To VEBMA.	VEBMA -	TF	N
To TOMAN.	TOMAN -	TF	N
To DODSO.	DODSO	TF	N

Tabular Descriptions

Path Term	Waypoint Name	Fly-Over	Course °M(°T)	Distance (NM)	Turn Direction	Altitude	Speed Limit	Navigation Spec
CF	LEDOX	-	203(203.4)	5.0	-	A015+	-	RNAV1
TF	LETGO	-	203(203.4)	3.0	L	A025+	-	RNAV1
TF	DUBOT	-	135(135.4)	8.0	L	A040+	-	RNAV1
TF	ERVIV	-	113(113.4)	10.0	L	@A060	-	RNAV1
TF	MUMDU	-	088(088.4)	17.0	L	-	-	RNAV1
TF	SEBVO	-	045(045.4)	11.0	-	A090-	-	RNAV1
TF	GOTGA	-	045(045.4)	10.0	R	-	-	RNAV1
TF	VEBMA	-	088(088.4)	12.0	-	-	-	RNAV1
TF	TOMAN	-	088(088.4)	54.0	-	-	-	RNAV1
TF	DODSO	-	088(088.4)	27.0	-	-	-	RNAV1

Radio Communications Failure Procedure

1	SET TRANSPONDER TO MODE A/C CODE 7600
2	COMMUNICATIONS FAILURE OCCURS IMMEDIATELY AFTER DEPARTURE: PROCEED DIRECT TO SAMKO HOLDING AREA (SHA) CLIMBING TO THE LAST ASSIGNED ALTITUDE, THEREAFTER REFER TO SINGAPORE AIP ON RADIO COMMUNICATIONS FAILURE PROCEDURE.

STANDARD DEPARTURE CHART
RNAV (GNSS) -
INSTRUMENT (SID)

TWR 118.6 / 118.25 APP 120.3 124.05 ACC 134.4	TRANSITION ALTITUDE 11 000ft
	D-ATIS AP ID-WSSS 128.6

SINGAPORE/Singapore Changi
RWY 02C
IDBUD DEPARTURES
IDBUD 1A

ELEV, ALT IN FEET
BEARINGS, TRACKS AND
RADIALS ARE MAGNETIC
VAR 0°23'E (2020)

DISTANCES IN NM

TEKONG
DVOR/DME 116.5
VTK
01°24'55"N
104°01'20"E
60M

DER (RWY 02C)
01°21'45.00"N
103°59'57.00"E

MOXIB
01°29'33"N
104°03'15"E
A020

EMRIX
01°26'06"N
104°10'40"E
A040

HOSBA
01°19'48"N
104°24'18"E
A070

VANBU
01°06'43"N
104°27'40"E
A090

VIRET
00°39'40"N
104°35'11"E
FL160

GURES
00°28'14"N
104°38'35"E

IDBUD
00°14'54"N
105°01'39"E

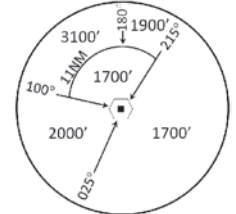

MSA 25 NM
from TEKONG DVOR

GENERAL INFORMATION

INITIAL CLIMB
3000FT

CAUTION: RWY 02R/20L NOT AVAILABLE FOR CIVIL USE UNTIL FURTHER ADVISED

NOTE: RADAR REQUIRED

NOTE: RNAV-1 NAVIGATION SPECIFICATION GNSS REQUIRED

NOTE: CLOSE-IN OBSTACLES (AIRCRAFT UP TO 80FT) EXIST ON TAXIWAYS WEST OF RUNWAY 02C

NOTE: ACFT UNABLE TO FLY THE SID PROFILE SHALL INFORM ATC PRIOR TO DEPARTURE AND EXPECT RADAR VECTORING IF NECESSARY

NOTE: WHEN TAKEN OFF THE SID, AS INSTRUCTED BY ATC, REFER TO ENR 1.5, SECTION 3, PARAGRAPH 3.3 [A] - FOR RWY 02C MINIMUM CLIMB GRADIENT

NOTE: REFER TO BACK PAGE FOR
- FORMAL AND TABULAR DESCRIPTIONS
- RADIO COM FAILURE PROCEDURES

PROCEDURE INFORMATION

SID SHALL NOT EXCEED IAS 230KTS UNTIL PASSING 4000FT AMSL AND NOT EXCEED IAS 250KTS UNTIL PASSING 10000FT AMSL.

CRUISING LEVELS WILL BE ISSUED AFTER TAKE-OFF BY SINGAPORE RADAR.

SID SHALL BE ON A MINIMUM CLIMB GRADIENT OF 5% UNTIL REACHING OR PASSING 2500FT, THEREAFTER 3.3%.

GND SPEED - KNOTS	75	100	150	200	250	300
5% V/V (fpm)	380	506	760	1013	1266	1519
3.3% V/V (fpm)	251	334	501	668	835	1003

NOT TO SCALE

IDBUD 1A (SID) RNAV GNSS RWY 02C - DESCRIPTIONS

Formal & Abbreviated Descriptions

Formal Description	Abbreviated Description	Path Terminator	Fly-Over required
To MOXIB on course 023° at or above 2000ft, turn right.	MOXIB [M023; A020+; R] -	CF	N
To EMRIX at or above 4000ft.	EMRIX [A040+] -	TF	N
To HOSBA at or above 7000ft, turn right.	HOSBA [A070+; R] -	TF	N
To VANBU at or below 9000ft, turn left.	VANBU [A090-; L] -	TF	N
To VIRET at or above FL160, turn left.	VIRET [FL160+; L] -	TF	N
To GURES, turn left	GURES [L] -	TF	N
To IDBUD.	IDBUD	TF	N

Tabular Descriptions

Path Term	Waypoint Name	Fly-Over	Course °M(°T)	Distance (NM)	Turn Direction	Altitude	Speed Limit	Navigation Spec
CF	MOXIB	-	023(023.4)	8.0	R	A020+	-	RNAV1
TF	EMRIX	-	114(114.4)	8.0	-	A040+	-	RNAV1
TF	HOSBA	-	114(114.4)	15.0	R	A070+	-	RNAV1
TF	VANBU	-	165(165.4)	13.0	L	A090-	-	RNAV1
TF	VIRET	-	164(164.4)	28.0	L	FL160+	-	RNAV1
TF	GURES	-	163(163.4)	12.0	L	-	-	RNAV1
TF	IDBUD	-	119(119.4)	27.0	-	-	-	RNAV1

Radio Communications Failure Procedure

1	SET TRANSPONDER TO MODE A/C CODE 7600
2	<p>COMMUNICATIONS FAILURE OCCURS IMMEDIATELY AFTER DEPARTURE:</p> <p>PROCEED DIRECT TO NYLON HOLDING AREA (NHA) CLIMBING TO THE LAST ASSIGNED ALTITUDE, THEREAFTER REFER TO SINGAPORE AIP ON RADIO COMMUNICATIONS FAILURE PROCEDURE.</p>

STANDARD DEPARTURE CHART
RNAV (GNSS) -
INSTRUMENT (SID)

TWR 118.6 / 118.25
APP 120.3
124.05
ACC 134.4

TRANSITION ALTITUDE
11 000ft

D-ATIS AP ID-WSSS
128.6

SINGAPORE/Singapore Changi
RWY 20C
IDBUD DEPARTURES
IDBUD 1B

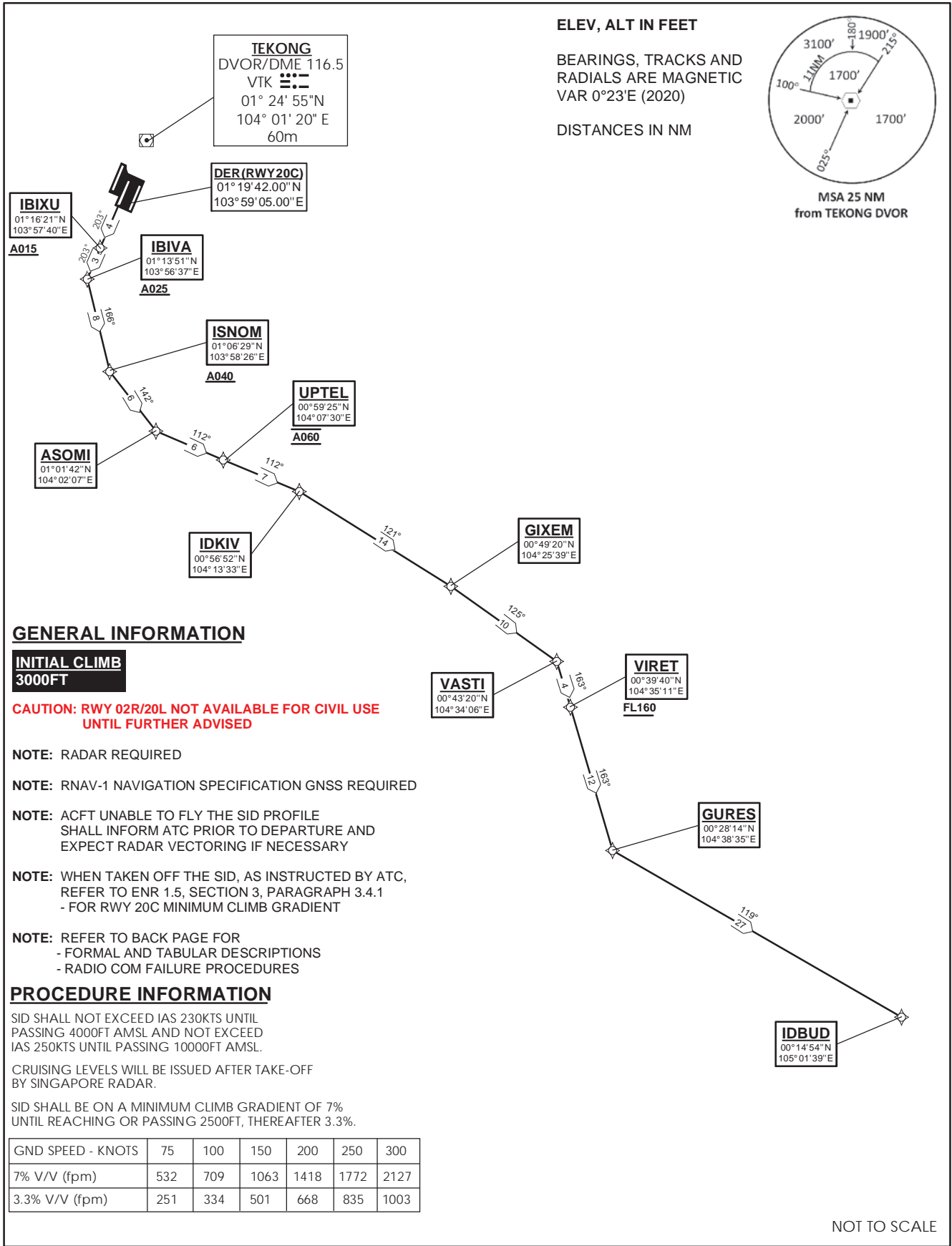

IDBUD 1B (SID) RNAV GNSS RWY 20C - DESCRIPTIONS

Formal & Abbreviated Descriptions

Formal Description	Abbreviated Description	Path Terminator	Fly-Over required
To IBIXU on course 203° at or above 1500ft.	IBIXU [M203; A015+] -	CF	N
To IBIVA at or above 2500ft, turn left.	IBIVA [A025+; L] -	TF	N
To ISNOM at or above 4000ft, turn left.	ISNOM [A040+; L] -	TF	N
To ASOMI, turn left.	ASOMI [L] -	TF	N
To UPTTEL at 6000ft.	UPTTEL [@A060] -	TF	N
To IDKIV, turn right.	IDKIV [R] -	TF	N
To GIXEM, turn right.	GIXEM [R] -	TF	N
To VASTI, turn right.	VASTI [R] -	TF	N
To VIRET at or above FL160.	VIRET [FL160+] -	TF	N
To GURES, turn left.	GURES [L] -	TF	N
To IDBUD.	IDBUD	TF	N

Tabular Descriptions

Path Term	Waypoint Name	Fly-Over	Course °M(°T)	Distance (NM)	Turn Direction	Altitude	Speed Limit	Navigation Spec
CF	IBIXU	-	203(203.4)	4.0	-	A015+	-	RNAV1
TF	IBIVA	-	203(203.4)	3.0	L	A025+	-	RNAV1
TF	ISNOM	-	166(166.4)	8.0	L	A040+	-	RNAV1
TF	ASOMI	-	142(142.4)	6.0	L	-	-	RNAV1
TF	UPTTEL	-	112(112.4)	6.0	-	@A060	-	RNAV1
TF	IDKIV	-	112(112.4)	7.0	R	-	-	RNAV1
TF	GIXEM	-	121(121.4)	14.0	R	-	-	RNAV1
TF	VASTI	-	125(125.4)	10.0	R	-	-	RNAV1
TF	VIRET	-	163(163.4)	4.0	-	FL160+	-	RNAV1
TF	GURES	-	163(163.4)	12.0	L	-	-	RNAV1
TF	IDBUD	-	119(119.4)	27.0	-	-	-	RNAV1

Radio Communications Failure Procedure

1	SET TRANSPONDER TO MODE A/C CODE 7600
2	COMMUNICATIONS FAILURE OCCURS IMMEDIATELY AFTER DEPARTURE: PROCEED DIRECT TO SAMKO HOLDING AREA (SHA) CLIMBING TO THE LAST ASSIGNED ALTITUDE, THEREAFTER REFER TO SINGAPORE AIP ON RADIO COMMUNICATIONS FAILURE PROCEDURE.

STANDARD DEPARTURE CHART
RNAV (GNSS) -
INSTRUMENT (SID)

TWR 118.6 / 118.25
APP 120.3
124.05
ACC 134.4

TRANSITION ALTITUDE
11 000ft

D-ATIS AP ID-WSSS
128.6

SINGAPORE/Singapore Changi
RWY 02R
IDBUD DEPARTURES (RADAR)
IDBUD 1C

ELEV, ALT IN FEET
BEARINGS, TRACKS AND
RADIALS ARE MAGNETIC
VAR 0°23'E (2020)

DISTANCES IN NM

TEKONG
DVOR/DME 116.5
VTK 
01°24'55"N
104°01'20"E
60M

DER (RWY02R)
01°21'22"N
104°00'51"E

**EXPECT RADAR vectors
to waypoint HOSBA**

HOSBA
01°19'48"N
104°24'18"E
A070

VANBU
01°06'43"N
104°27'40"E
A090

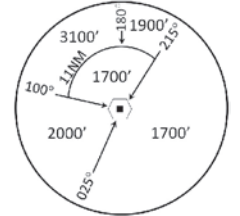

MSA 25 NM
from TEKONG DVOR

GENERAL INFORMATION

INITIAL CLIMB
3000FT

CAUTION: RWY 02R/20L NOT AVAILABLE FOR CIVIL USE UNTIL FURTHER ADVISED

NOTE: RADAR REQUIRED

NOTE: RNAV-1 NAVIGATION SPECIFICATION GNSS REQUIRED

NOTE: ACFT UNABLE TO FLY THE SID PROFILE
SHALL INFORM ATC PRIOR TO DEPARTURE AND
EXPECT RADAR VECTORED IF NECESSARY

NOTE: WHEN TAKEN OFF THE SID, AS INSTRUCTED BY ATC,
REFER TO ENR 1.5, SECTION 3, PARAGRAPH 3.5
- FOR RWY 02R MINIMUM CLIMB GRADIENT

NOTE: REFER TO BACK PAGE FOR
- FORMAL AND TABULAR DESCRIPTIONS
- RADIO COM FAILURE PROCEDURES

PROCEDURE INFORMATION

SID SHALL NOT EXCEED IAS 230KTS UNTIL
PASSING 4000FT AMSL AND NOT EXCEED
IAS 250KTS UNTIL PASSING 10000FT AMSL.

CRUISING LEVELS WILL BE ISSUED AFTER TAKE-OFF
BY SINGAPORE RADAR.

SID SHALL BE ON A MINIMUM CLIMB GRADIENT OF 5%
UNTIL REACHING OR PASSING 2500FT, THEREAFTER 3.3%.

GND SPEED - KNOTS	75	100	150	200	250	300
5% V/V (fpm)	380	506	760	1013	1266	1519
3.3% V/V (fpm)	251	334	501	668	835	1003

GURES
00°28'14"N
104°38'35"E

VIRET
00°39'40"N
104°35'11"E
FL160

IDBUD
00°14'54"N
105°01'39"E

NOT TO SCALE

IDBUD 1C (SID) RNAV GNSS RWY 02R - DESCRIPTIONS

Formal & Abbreviated Descriptions

Formal Description	Abbreviated Description	Path Terminator	Fly-Over required
Climb heading 023°, Gradient 5% to 2500ft, thence 3.3%. Expect radar vectors to waypoint HOSBA.	-	VA	N
To HOSBA at or above 7000ft.	HOSBA [A070+] -	DF	N
To VANBU at or below 9000ft, turn left.	VANBU [A090-; L] -	TF	N
To VIRET at or above FL160, turn left.	VIRET [FL160+; L] -	TF	N
To GURES, turn left.	GURES [L] -	TF	N
To IDBUD.	IDBUD	TF	N

Tabular Descriptions

Path Term	Waypoint Name	Fly-Over	Course °M(°T)	Distance (NM)	Turn Direction	Altitude	Speed Limit	Navigation Spec
VA	-	-	023(023.4)	-	-	A030	-	-
DF	HOSBA	-	-	-	-	A070+	-	RNAV1
TF	VANBU	-	165(165.4)	13.0	L	A090-	-	RNAV1
TF	VIRET	-	164(164.4)	28.0	L	FL160+	-	RNAV1
TF	GURES	-	163(163.3)	12.0	L	-	-	RNAV1
TF	IDBUD	-	119(119.3)	27.0	-	-	-	RNAV1

Radio Communications Failure Procedure

1	SET TRANSPONDER TO MODE A/C CODE 7600
2	<p>COMMUNICATIONS FAILURE OCCURS IMMEDIATELY AFTER DEPARTURE:</p> <p>PROCEED DIRECT TO NYLON HOLDING AREA (NHA) CLIMBING TO THE LAST ASSIGNED ALTITUDE, THEREAFTER REFER TO SINGAPORE AIP ON RADIO COMMUNICATIONS FAILURE PROCEDURE.</p>

STANDARD DEPARTURE CHART
RNAV (GNSS) -
INSTRUMENT (SID)

TWR 118.6 / 118.25
APP 120.3
124.05
ACC 134.4

TRANSITION ALTITUDE
11 000ft

D-ATIS AP ID-WSSS
128.6

SINGAPORE/Singapore Changi
RWY 20L
IDBUD DEPARTURES
IDBUD 1D

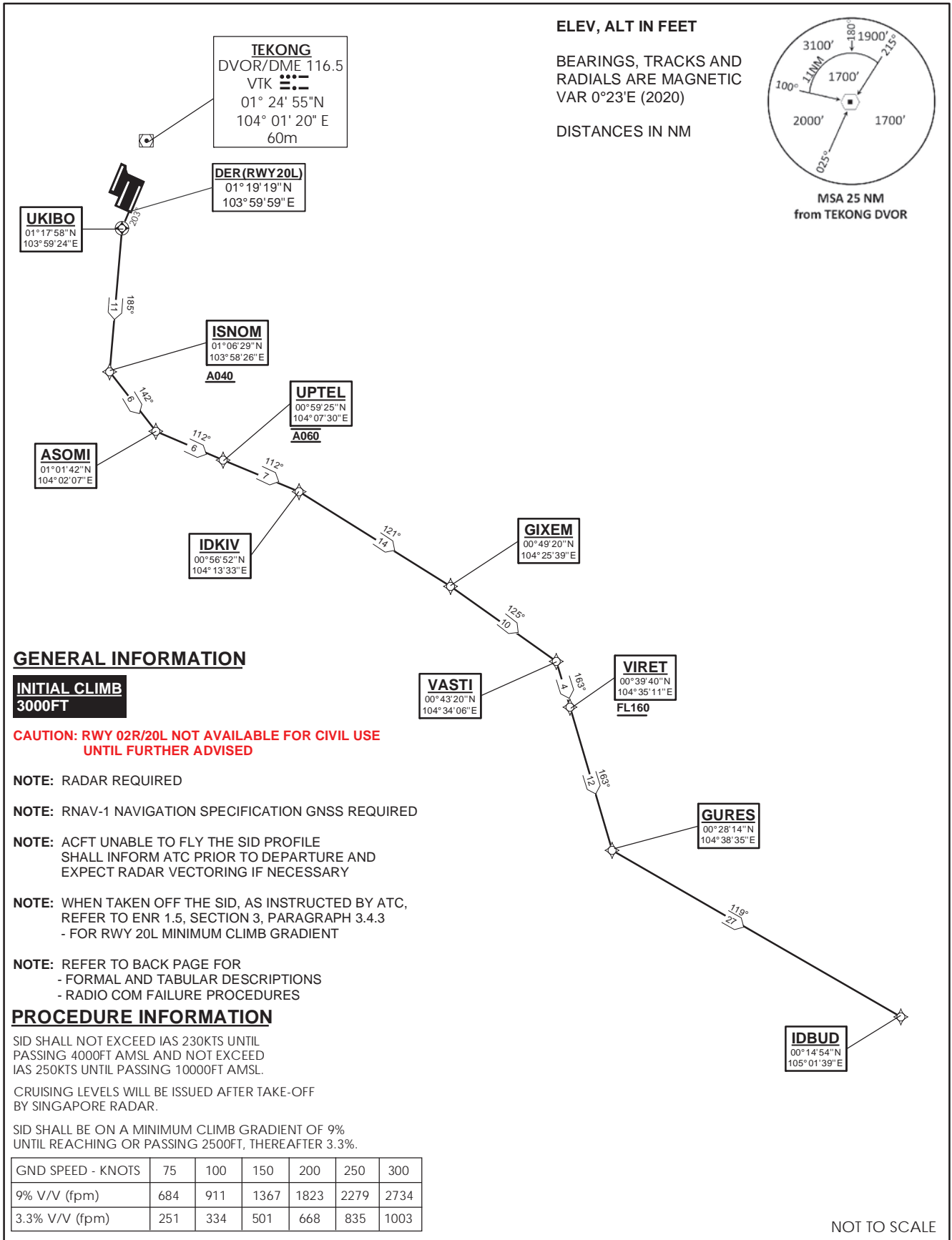

31 OCT 2024

IDBUD 1D (SID) RNAV GNSS RWY 20L - DESCRIPTIONS**Formal & Abbreviated Descriptions**

Formal Description	Abbreviated Description	Path Terminator	Fly-Over required
To UKIBO on course 203°, turn left.	UKIBO [M203; L] -	CF	N
To ISNOM at or above 4000ft, turn left.	ISNOM [A040+; L] -	TF	N
To ASOMI, turn left.	ASOMI [L] -	TF	N
To UPTTEL at 6000ft.	UPTTEL [@A060] -	TF	N
To IDKIV, turn right.	IDKIV [R] -	TF	N
To GIXEM, turn right.	GIXEM [R] -	TF	N
To VASTI, turn right.	VASTI [R] -	TF	N
To VIRET at or above FL160.	VIRET [FL160+] -	TF	N
To GURES, turn left.	GURES [L] -	TF	N
To IDBUD.	IDBUD	TF	N

Tabular Descriptions

Path Term	Waypoint Name	Fly-Over	Course °M(°T)	Distance (NM)	Turn Direction	Altitude	Speed Limit	Navigation Spec
CF	UKIBO	Y	203(203.4)	1.5	L	-	-	RNAV1
TF	ISNOM	-	185(185.4)	11.0	L	A040+	-	RNAV1
TF	ASOMI	-	142(142.4)	6.0	L	-	-	RNAV1
TF	UPTTEL	-	112(112.4)	6.0	-	@A060	-	RNAV1
TF	IDKIV	-	112(112.4)	7.0	R	-	-	RNAV1
TF	GIXEM	-	121(121.4)	14.0	R	-	-	RNAV1
TF	VASTI	-	125(125.4)	10.0	R	-	-	RNAV1
TF	VIRET	-	163(163.4)	4.0	-	FL160+	-	RNAV1
TF	GURES	-	163(163.4)	12.0	L	-	-	RNAV1
TF	IDBUD	-	119(119.4)	27.0	-	-	-	RNAV1

Radio Communications Failure Procedure

1	SET TRANSPONDER TO MODE A/C CODE 7600
2	COMMUNICATIONS FAILURE OCCURS IMMEDIATELY AFTER DEPARTURE: PROCEED DIRECT TO SAMKO HOLDING AREA (SHA) CLIMBING TO THE LAST ASSIGNED ALTITUDE, THEREAFTER REFER TO SINGAPORE AIP ON RADIO COMMUNICATIONS FAILURE PROCEDURE.

STANDARD DEPARTURE CHART
RNAV (GNSS) -
INSTRUMENT (SID)

TWR 118.6 / 118.25 APP 120.3 124.05 ACC 134.4	TRANSITION ALTITUDE 11 000ft
D-ATIS AP ID-WSSS 128.6	

SINGAPORE/Singapore Changi
RWY 02L
IDBUD DEPARTURES
IDBUD 1E

ELEV, ALT IN FEET
BEARINGS, TRACKS AND
RADIALS ARE MAGNETIC
VAR 0°23'E (2020)

DISTANCES IN NM

TEKONG
DVOR/DME 116.5
VTK 
01°24'55"N
104°01'20"E
60M

DER (RWY 02L)
01°23'05.00"N
103°59'33.00"E

MOLVO
01°29'55"N
104°02'27"E

A020

EMRIX
01°26'06"N
104°10'40"E

A040

HOSBA
01°19'48"N
104°24'18"E

A070

VANBU
01°06'43"N
104°27'40"E

A090

VIRET
00°39'40"N
104°35'11"E

FL160

GURES
00°28'14"N
104°38'35"E

IDBUD
00°14'54"N
105°01'39"E

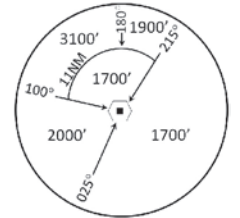

MSA 25 NM
from TEKONG DVOR

GENERAL INFORMATION

INITIAL CLIMB
3000FT

CAUTION: RWY 02R/20L NOT AVAILABLE FOR CIVIL USE UNTIL FURTHER ADVISED

NOTE: RADAR REQUIRED

NOTE: RNAV-1 NAVIGATION SPECIFICATION GNSS REQUIRED

NOTE: ACFT UNABLE TO FLY THE SID PROFILE SHALL INFORM ATC PRIOR TO DEPARTURE AND EXPECT RADAR VECTORIZING IF NECESSARY

NOTE: WHEN TAKEN OFF THE SID, AS INSTRUCTED BY ATC, REFER TO ENR 1.5, SECTION 3, PARAGRAPH 3.2 [A] - FOR RWY 02L MINIMUM CLIMB GRADIENT

NOTE: REFER TO BACK PAGE FOR
- FORMAL AND TABULAR DESCRIPTIONS
- RADIO COM FAILURE PROCEDURES

PROCEDURE INFORMATION

SID SHALL NOT EXCEED IAS 230KTS UNTIL PASSING 4000FT AMSL AND NOT EXCEED IAS 250KTS UNTIL PASSING 10000FT AMSL.

CRUISING LEVELS WILL BE ISSUED AFTER TAKE-OFF BY SINGAPORE RADAR.

SID SHALL BE ON A MINIMUM CLIMB GRADIENT OF 5% UNTIL REACHING OR PASSING 2500FT, THEREAFTER 3.3%.

GND SPEED - KNOTS	75	100	150	200	250	300
5% V/V (fpm)	380	506	760	1013	1266	1519
3.3% V/V (fpm)	251	334	501	668	835	1003

NOT TO SCALE

IDBUD 1E (SID) RNAV GNSS RWY 02L - DESCRIPTIONS

Formal & Abbreviated Descriptions

Formal Description	Abbreviated Description	Path Terminator	Fly-Over required
To MOLVO on course 023° at or above 2000ft, turn right.	MOLVO [M023; A020+; R] -	CF	N
To EMRIX at or above 4000ft.	EMRIX [A040+] -	TF	N
To HOSBA at or above 7000ft, turn right.	HOSBA [A070+; R] -	TF	N
To VANBU at or below 9000ft, turn left.	VANBU [A090-; L] -	TF	N
To VIRET at or above FL160, turn left.	VIRET [FL160+; L] -	TF	N
To GURES, turn left	GURES [L] -	TF	N
To IDBUD.	IDBUD	TF	N

Tabular Descriptions

Path Term	Waypoint Name	Fly-Over	Course °M(°T)	Distance (NM)	Turn Direction	Altitude	Speed Limit	Navigation Spec
CF	MOLVO	-	023(023.4)	8.0	R	A020+	-	RNAV1
TF	EMRIX	-	114(114.4)	9.0	-	A040+	-	RNAV1
TF	HOSBA	-	114(114.4)	15.0	R	A070+	-	RNAV1
TF	VANBU	-	165(165.4)	13.0	L	A090-	-	RNAV1
TF	VIRET	-	164(164.4)	28.0	L	FL160+	-	RNAV1
TF	GURES	-	163(163.4)	12.0	L	-	-	RNAV1
TF	IDBUD	-	119(119.4)	27.0	-	-	-	RNAV1

Radio Communications Failure Procedure

1	SET TRANSPONDER TO MODE A/C CODE 7600
2	<p>COMMUNICATIONS FAILURE OCCURS IMMEDIATELY AFTER DEPARTURE:</p> <p>PROCEED DIRECT TO NYLON HOLDING AREA (NHA) CLIMBING TO THE LAST ASSIGNED ALTITUDE, THEREAFTER REFER TO SINGAPORE AIP ON RADIO COMMUNICATIONS FAILURE PROCEDURE.</p>

STANDARD DEPARTURE CHART
RNAV (GNSS) -
INSTRUMENT (SID)

TWR 118.6 / 118.25
APP 120.3
124.05
ACC 134.4

TRANSITION ALTITUDE
11 000ft

D-ATIS AP ID-WSSS
128.6

SINGAPORE/Singapore Changi
RWY 20R
IDBUD DEPARTURES
IDBUD 1F

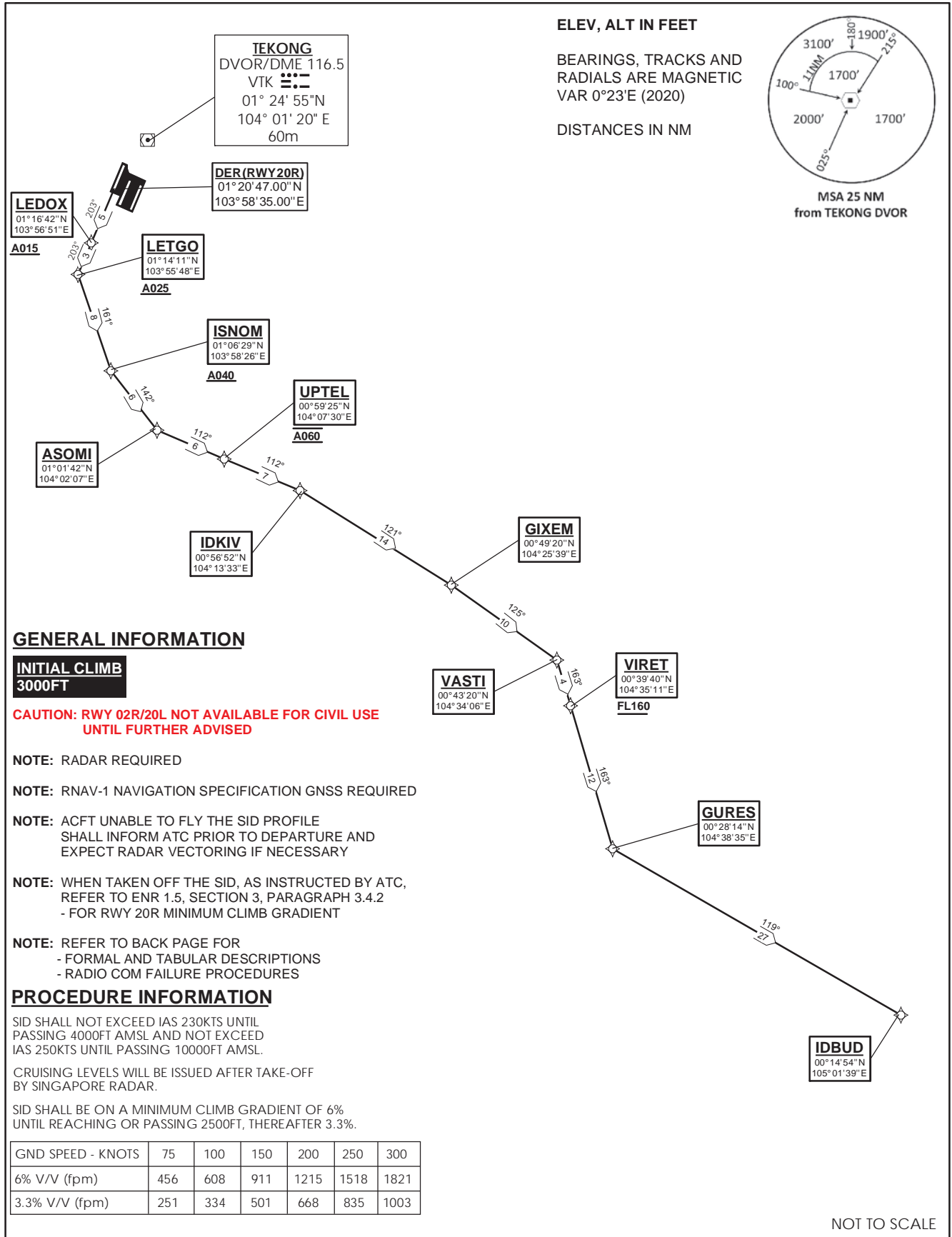

IDBUD 1F (SID) RNAV GNSS RWY 20R - DESCRIPTIONS

Formal & Abbreviated Descriptions

Formal Description	Abbreviated Description	Path Terminator	Fly-Over required
To LEDOX on course 203° at or above 1500ft.	LEDOX [M203; A015+] -	CF	N
To LETGO at or above 2500ft, turn left.	LETGO [A025+; L] -	TF	N
To ISNOM at or above 4000ft, turn left.	ISNOM [A040+; L] -	TF	N
To ASOMI, turn left.	ASOMI [L] -	TF	N
To UPTTEL at 6000ft.	UPTTEL [@A060] -	TF	N
To IDKIV, turn right.	IDKIV [R] -	TF	N
To GIXEM, turn right.	GIXEM [R] -	TF	N
To VASTI, turn right.	VASTI [R] -	TF	N
To VIRET at or above FL160.	VIRET [FL160+] -	TF	N
To GURES, turn left.	GURES [L] -	TF	N
To IDBUD.	IDBUD	TF	N

Tabular Descriptions

Path Term	Waypoint Name	Fly-Over	Course °M(°T)	Distance (NM)	Turn Direction	Altitude	Speed Limit	Navigation Spec
CF	LEDOX	-	203(203.4)	5.0	-	A015+	-	RNAV1
TF	LETGO	-	203(203.4)	3.0	L	A025+	-	RNAV1
TF	ISNOM	-	161(161.4)	8.0	L	A040+	-	RNAV1
TF	ASOMI	-	142(142.4)	6.0	L	-	-	RNAV1
TF	UPTTEL	-	112(112.4)	6.0	-	@A060	-	RNAV1
TF	IDKIV	-	112(112.4)	7.0	R	-	-	RNAV1
TF	GIXEM	-	121(121.4)	14.0	R	-	-	RNAV1
TF	VASTI	-	125(125.4)	10.0	R	-	-	RNAV1
TF	VIRET	-	163(163.4)	4.0	-	FL160+	-	RNAV1
TF	GURES	-	163(163.4)	12.0	L	-	-	RNAV1
TF	IDBUD	-	119(119.4)	27.0	-	-	-	RNAV1

Radio Communications Failure Procedure

1	SET TRANSPONDER TO MODE A/C CODE 7600
2	COMMUNICATIONS FAILURE OCCURS IMMEDIATELY AFTER DEPARTURE: PROCEED DIRECT TO SAMKO HOLDING AREA (SHA) CLIMBING TO THE LAST ASSIGNED ALTITUDE, THEREAFTER REFER TO SINGAPORE AIP ON RADIO COMMUNICATIONS FAILURE PROCEDURE.

STANDARD DEPARTURE CHART
RNAV (GNSS) -
INSTRUMENT (SID)

TWR 118.6 / 118.25 APP 120.3 124.05 ACC 134.4	TRANSITION ALTITUDE 11 000ft
D-ATIS AP ID-WSSS 128.6	

SINGAPORE/Singapore Changi
RWY 02C
KIRDA DEPARTURES
KIRDA 1A

ELEV, ALT IN FEET
BEARINGS, TRACKS AND
RADIALS ARE MAGNETIC
VAR 0°23'E (2020)

DISTANCES IN NM

TEKONG
DVOR/DME 116.5
VTK 
01°24'55"N
104°01'20"E
60M

DER (RWY 02C)
01°21'45.00"N
103°59'57.00"E

MOXIB
01°29'33"N
104°03'15"E

A020

EMRIX
01°26'06"N
104°10'40"E

A040

HOSBA
01°19'48"N
104°24'18"E

A070

VANBU
01°06'43"N
104°27'40"E

A090

VIRET
00°39'40"N
104°35'11"E

FL160

GURES
00°28'14"N
104°38'35"E

IKIRO
00°08'49"N
104°44'20"E

KIRDA
00°00'09"N
104°59'34"E

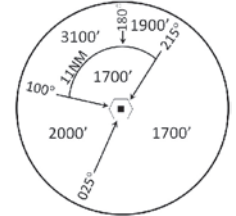

GENERAL INFORMATION

INITIAL CLIMB
3000FT

CAUTION: RWY 02R/20L NOT AVAILABLE FOR CIVIL USE UNTIL FURTHER ADVISED

NOTE: RADAR REQUIRED

NOTE: RNAV-1 NAVIGATION SPECIFICATION GNSS REQUIRED

NOTE: CLOSE-IN OBSTACLES (AIRCRAFT UP TO 80FT) EXIST ON TAXIWAYS WEST OF RUNWAY 02C

NOTE: ACFT UNABLE TO FLY THE SID PROFILE SHALL INFORM ATC PRIOR TO DEPARTURE AND EXPECT RADAR VECTORED IF NECESSARY

NOTE: WHEN TAKEN OFF THE SID, AS INSTRUCTED BY ATC, REFER TO ENR 1.5, SECTION 3, PARAGRAPH 3.3 [A] - FOR RWY 02C MINIMUM CLIMB GRADIENT

NOTE: REFER TO BACK PAGE FOR
- FORMAL AND TABULAR DESCRIPTIONS
- RADIO COM FAILURE PROCEDURES

PROCEDURE INFORMATION

SID SHALL NOT EXCEED IAS 230KTS UNTIL PASSING 4000FT AMSL AND NOT EXCEED IAS 250KTS UNTIL PASSING 10000FT AMSL.

CRUISING LEVELS WILL BE ISSUED AFTER TAKE-OFF BY SINGAPORE RADAR.

SID SHALL BE ON A MINIMUM CLIMB GRADIENT OF 5% UNTIL REACHING OR PASSING 2500FT, THEREAFTER 3.3%.

GND SPEED - KNOTS	75	100	150	200	250	300
5% V/V (fpm)	380	506	760	1013	1266	1519
3.3% V/V (fpm)	251	334	501	668	835	1003

NOT TO SCALE

KIRDA 1A (SID) RNAV GNSS RWY 02C - DESCRIPTIONS

Formal & Abbreviated Descriptions

Formal Description	Abbreviated Description	Path Terminator	Fly-Over required
To MOXIB on course 023° at or above 2000ft, turn right.	MOXIB [M023; A020+; R] -	CF	N
To EMRIX at or above 4000ft.	EMRIX [A040+] -	TF	N
To HOSBA at or above 7000ft, turn right.	HOSBA [A070+; R] -	TF	N
To VANBU at or below 9000ft, turn left.	VANBU [A090-; L] -	TF	N
To VIRET at or above FL160, turn left.	VIRET [FL160+; L] -	TF	N
To GURES.	GURES -	TF	N
To IKIRO, turn left.	IKIRO [L] -	TF	N
To KIRDA.	KIRDA	TF	N

Tabular Descriptions

Path Term	Waypoint Name	Fly-Over	Course °M(°T)	Distance (NM)	Turn Direction	Altitude	Speed Limit	Navigation Spec
CF	MOXIB	-	023(023.4)	8.0	R	A020+	-	RNAV1
TF	EMRIX	-	114(114.4)	8.0	-	A040+	-	RNAV1
TF	HOSBA	-	114(114.4)	15.0	R	A070+	-	RNAV1
TF	VANBU	-	165(165.4)	13.0	L	A090-	-	RNAV1
TF	VIRET	-	164(164.4)	28.0	L	FL160+	-	RNAV1
TF	GURES	-	163(163.4)	12.0	-	-	-	RNAV1
TF	IKIRO	-	163(163.4)	20.0	L	-	-	RNAV1
TF	KIRDA	-	119(119.4)	18.0	-	-	-	RNAV1

Radio Communications Failure Procedure

1	SET TRANSPONDER TO MODE A/C CODE 7600
2	<p>COMMUNICATIONS FAILURE OCCURS IMMEDIATELY AFTER DEPARTURE:</p> <p>PROCEED DIRECT TO NYLON HOLDING AREA (NHA) CLIMBING TO THE LAST ASSIGNED ALTITUDE, THEREAFTER REFER TO SINGAPORE AIP ON RADIO COMMUNICATIONS FAILURE PROCEDURE.</p>

STANDARD DEPARTURE CHART
RNAV (GNSS) -
INSTRUMENT (SID)

TWR 118.6 / 118.25
APP 120.3
124.05
ACC 134.4

TRANSITION ALTITUDE
11 000ft

D-ATIS AP ID-WSSS
128.6

SINGAPORE/Singapore Changi
RWY 20C
KIRDA DEPARTURES
KIRDA 1B

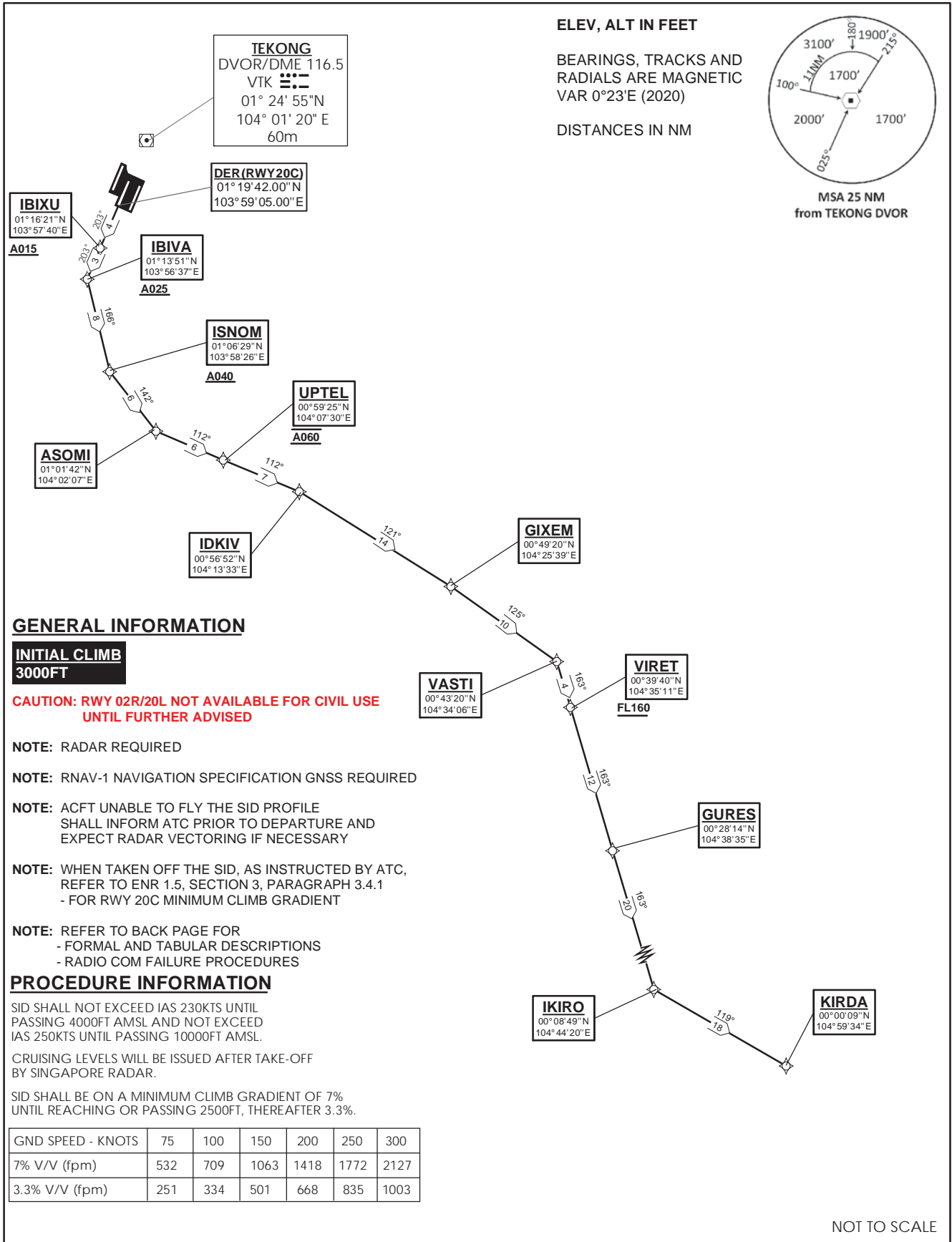

31 OCT 2024

KIRDA 1B (SID) RNAV GNSS RWY 20C - DESCRIPTIONS**Formal & Abbreviated Descriptions**

Formal Description	Abbreviated Description	Path Terminator	Fly-Over required
To IBIXU on course 203° at or above 1500ft.	IBIXU [M203; A015+] -	CF	N
To IBIVA at or above 2500ft, turn left.	IBIVA [A025+; L] -	TF	N
To ISNOM at or above 4000ft, turn left.	ISNOM [A040+; L] -	TF	N
To ASOMI, turn left.	ASOMI [L] -	TF	N
To UPTTEL at 6000ft.	UPTTEL [@A060] -	TF	N
To IDKIV, turn right.	IDKIV [R] -	TF	N
To GIXEM, turn right.	GIXEM [R] -	TF	N
To VASTI, turn right.	VASTI [R] -	TF	N
To VIRET at or above FL160.	VIRET [FL160+] -	TF	N
To GURES.	GURES -	TF	N
To IKIRO, turn left.	IKIRO [L] -	TF	N
To KIRDA.	KIRDA	TF	N

Tabular Descriptions

Path Term	Waypoint Name	Fly-Over	Course °M(°T)	Distance (NM)	Turn Direction	Altitude	Speed Limit	Navigation Spec
CF	IBIXU	-	203(203.4)	4.0	-	A015+	-	RNAV1
TF	IBIVA	-	203(203.4)	3.0	L	A025+	-	RNAV1
TF	ISNOM	-	166(166.4)	8.0	L	A040+	-	RNAV1
TF	ASOMI	-	142(142.4)	6.0	L	-	-	RNAV1
TF	UPTTEL	-	112(112.4)	6.0	-	@A060	-	RNAV1
TF	IDKIV	-	112(112.4)	7.0	R	-	-	RNAV1
TF	GIXEM	-	121(121.4)	14.0	R	-	-	RNAV1
TF	VASTI	-	125(125.4)	10.0	R	-	-	RNAV1
TF	VIRET	-	163(163.4)	4.0	-	FL160+	-	RNAV1
TF	GURES	-	163(163.4)	12.0	-	-	-	RNAV1
TF	IKIRO	-	163(163.4)	20.0	L	-	-	RNAV1
TF	KIRDA	-	119(119.4)	18.0	-	-	-	RNAV1

Radio Communications Failure Procedure

1	SET TRANSPONDER TO MODE A/C CODE 7600
2	COMMUNICATIONS FAILURE OCCURS IMMEDIATELY AFTER DEPARTURE: PROCEED DIRECT TO SAMKO HOLDING AREA (SHA) CLIMBING TO THE LAST ASSIGNED ALTITUDE, THEREAFTER REFER TO SINGAPORE AIP ON RADIO COMMUNICATIONS FAILURE PROCEDURE.

STANDARD DEPARTURE CHART
RNAV (GNSS) -
INSTRUMENT (SID)

TWR 118.6 / 118.25
APP 120.3
124.05
ACC 134.4

TRANSITION ALTITUDE
11 000ft

D-ATIS AP ID-WSSS
128.6

SINGAPORE/Singapore Changi
RWY 02R
KIRDA DEPARTURES (RADAR)
KIRDA 1C

ELEV, ALT IN FEET
BEARINGS, TRACKS AND
RADIALS ARE MAGNETIC
VAR 0°23'E (2020)

DISTANCES IN NM

EXPECT RADAR vectors
to waypoint HOSBA

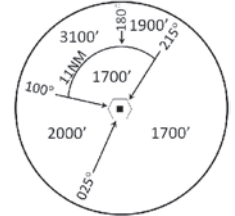

MSA 25 NM
from TEKONG DVOR

TEKONG
DVOR/DME 116.5
VTK
01°24'55"N
104°01'20"E
60M

DER(RWY02R)
01°21'22"N
104°00'51"E

HOSBA
01°19'48"N
104°24'18"E
A070

VANBU
01°06'43"N
104°27'40"E
A090

VIRET
00°39'40"N
104°35'11"E
FL160

GURES
00°28'14"N
104°38'35"E

IKIRO
00°08'49"N
104°44'20"E

KIRDA
00°00'09"N
104°59'34"E

GENERAL INFORMATION

INITIAL CLIMB
3000FT

CAUTION: RWY 02R/20L NOT AVAILABLE FOR CIVIL USE UNTIL FURTHER ADVISED

NOTE: RADAR REQUIRED

NOTE: RNAV-1 NAVIGATION SPECIFICATION GNSS REQUIRED

NOTE: ACFT UNABLE TO FLY THE SID PROFILE SHALL INFORM ATC PRIOR TO DEPARTURE AND EXPECT RADAR VECTORED IF NECESSARY

NOTE: WHEN TAKEN OFF THE SID, AS INSTRUCTED BY ATC, REFER TO ENR 1.5, SECTION 3, PARAGRAPH 3.5 - FOR RWY 02R MINIMUM CLIMB GRADIENT

NOTE: REFER TO BACK PAGE FOR
- FORMAL AND TABULAR DESCRIPTIONS
- RADIO COM FAILURE PROCEDURES

PROCEDURE INFORMATION

SID SHALL NOT EXCEED IAS 230KTS UNTIL PASSING 4000FT AMSL AND NOT EXCEED IAS 250KTS UNTIL PASSING 10000FT AMSL.

CRUISING LEVELS WILL BE ISSUED AFTER TAKE-OFF BY SINGAPORE RADAR.

SID SHALL BE ON A MINIMUM CLIMB GRADIENT OF 5% UNTIL REACHING OR PASSING 2500FT, THEREAFTER 3.3%.

GND SPEED - KNOTS	75	100	150	200	250	300
5% V/V (fpm)	380	506	760	1013	1266	1519
3.3% V/V (fpm)	251	334	501	668	835	1003

NOT TO SCALE

KIRDA 1C (SID) RNAV GNSS RWY 02R - DESCRIPTIONS

Formal & Abbreviated Descriptions

Formal Description	Abbreviated Description	Path Terminator	Fly-Over required
Climb heading 023°, Gradient 5% to 2500ft, thence 3.3%. Expect radar vectors to waypoint HOSBA.	-	VA	N
To HOSBA at or above 7000ft.	HOSBA [A070+] -	DF	N
To VANBU at or below 9000ft, turn left.	VANBU [A090-; L] -	TF	N
To VIRET at or above FL160, turn left.	VIRET [FL160+; L] -	TF	N
To GURES.	GURES -	TF	N
To IKIRO, turn left.	IKIRO [L] -	TF	N
To KIRDA.	KIRDA	TF	N

Tabular Descriptions

Path Term	Waypoint Name	Fly-Over	Course °M(°T)	Distance (NM)	Turn Direction	Altitude	Speed Limit	Navigation Spec
VA	-	-	023(023.4)	-	-	A030	-	-
DF	HOSBA	-	-	-	-	A070+	-	RNAV1
TF	VANBU	-	165(165.4)	13.0	L	A090-	-	RNAV1
TF	VIRET	-	164(164.4)	28.0	L	FL160+	-	RNAV1
TF	GURES	-	163(163.3)	12.0	-	-	-	RNAV1
TF	IKIRO	-	163(163.3)	20.0	L	-	-	RNAV1
TF	KIRDA	-	119(119.3)	18.0	-	-	-	RNAV1

Radio Communications Failure Procedure

1	SET TRANSPONDER TO MODE A/C CODE 7600
2	COMMUNICATIONS FAILURE OCCURS IMMEDIATELY AFTER DEPARTURE: PROCEED DIRECT TO NYLON HOLDING AREA (NHA) CLIMBING TO THE LAST ASSIGNED ALTITUDE, THEREAFTER REFER TO SINGAPORE AIP ON RADIO COMMUNICATIONS FAILURE PROCEDURE.

STANDARD DEPARTURE CHART
RNAV (GNSS) -
INSTRUMENT (SID)

TWR 118.6 / 118.25
APP 120.3
124.05
ACC 134.4

TRANSITION ALTITUDE
11 000ft

D-ATIS AP ID-WSSS
128.6

SINGAPORE/Singapore Changi
RWY 20L
KIRDA DEPARTURES
KIRDA 1D

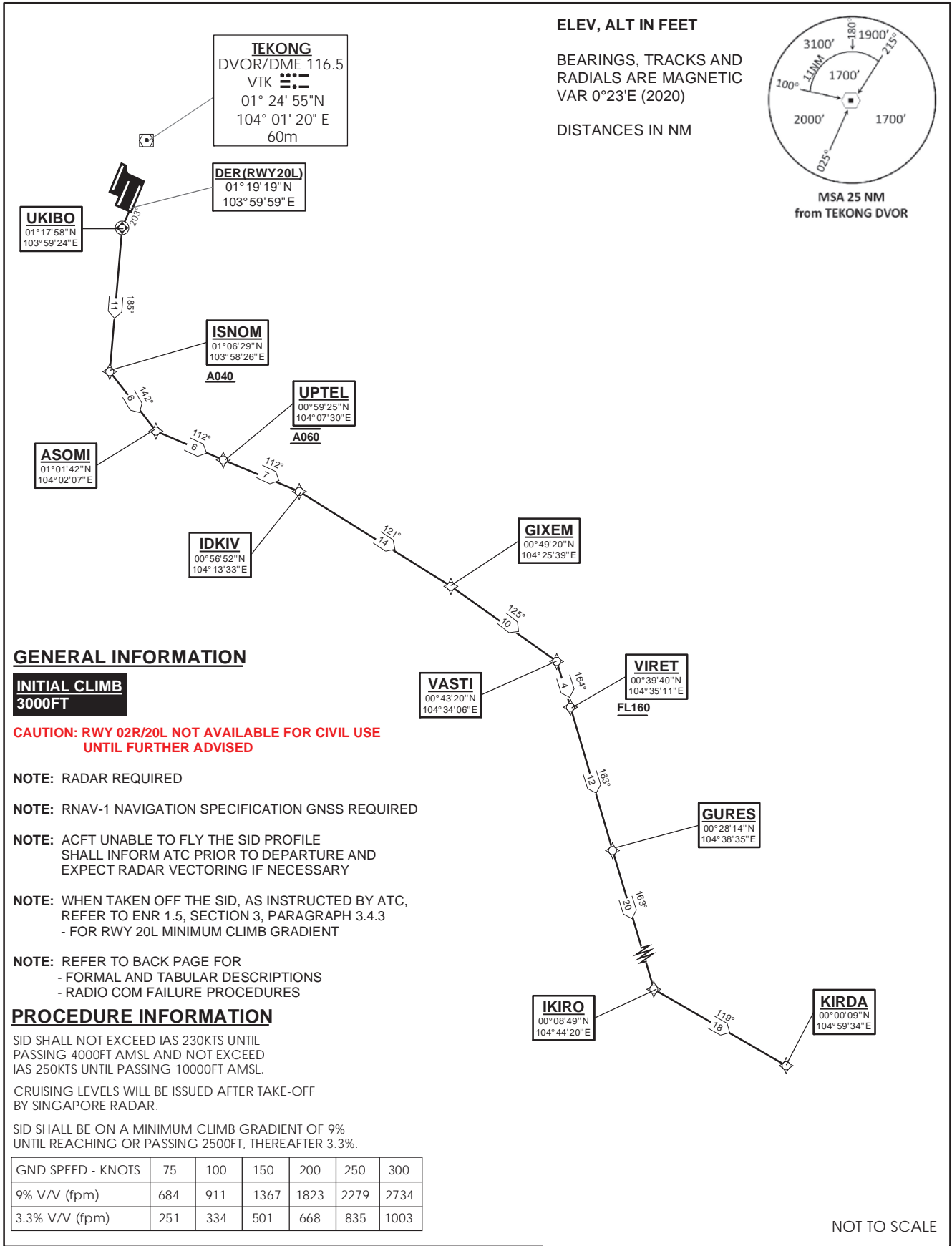

KIRDA 1D (SID) RNAV GNSS RWY 20L - DESCRIPTIONS

Formal & Abbreviated Descriptions

Formal Description	Abbreviated Description	Path Terminator	Fly-Over required
To UKIBO on course 203°, turn left.	UKIBO [M203; L] -	CF	N
To ISNOM at or above 4000ft, turn left.	ISNOM [A040+; L] -	TF	N
To ASOMI, turn left.	ASOMI [L] -	TF	N
To UPTTEL at 6000ft.	UPTTEL [@A060] -	TF	N
To IDKIV, turn right.	IDKIV [R] -	TF	N
To GIXEM, turn right.	GIXEM [R] -	TF	N
To VASTI, turn right.	VASTI [R] -	TF	N
To VIRET at or above FL160, turn left.	VIRET [FL160+; L] -	TF	N
To GURES.	GURES -	TF	N
To IKIRO, turn left.	IKIRO [L] -	TF	N
To KIRDA.	KIRDA	TF	N

Tabular Descriptions

Path Term	Waypoint Name	Fly-Over	Course °M(°T)	Distance (NM)	Turn Direction	Altitude	Speed Limit	Navigation Spec
CF	UKIBO	Y	203(203.4)	1.5	L	-	-	RNAV1
TF	ISNOM	-	185(185.4)	11.0	L	A040+	-	RNAV1
TF	ASOMI	-	142(142.4)	6.0	L	-	-	RNAV1
TF	UPTTEL	-	112(112.4)	6.0	-	@A060	-	RNAV1
TF	IDKIV	-	112(112.4)	7.0	R	-	-	RNAV1
TF	GIXEM	-	121(121.4)	14.0	R	-	-	RNAV1
TF	VASTI	-	125(125.4)	10.0	R	-	-	RNAV1
TF	VIRET	-	164(164.4)	4.0	L	FL160+	-	RNAV1
TF	GURES	-	163(163.4)	12.0	-	-	-	RNAV1
TF	IKIRO	-	163(163.4)	20.0	L	-	-	RNAV1
TF	KIRDA	-	119(119.4)	18.0	-	-	-	RNAV1

Radio Communications Failure Procedure

1	SET TRANSPONDER TO MODE A/C CODE 7600
2	COMMUNICATIONS FAILURE OCCURS IMMEDIATELY AFTER DEPARTURE: PROCEED DIRECT TO SAMKO HOLDING AREA (SHA) CLIMBING TO THE LAST ASSIGNED ALTITUDE, THEREAFTER REFER TO SINGAPORE AIP ON RADIO COMMUNICATIONS FAILURE PROCEDURE.

STANDARD DEPARTURE CHART
RNAV (GNSS) -
INSTRUMENT (SID)

TWR 118.6 / 118.25 APP 120.3 124.05 ACC 134.4	TRANSITION ALTITUDE 11 000ft
D-ATIS AP ID-WSSS 128.6	

SINGAPORE/Singapore Changi
RWY 02L
KIRDA DEPARTURES
KIRDA 1E

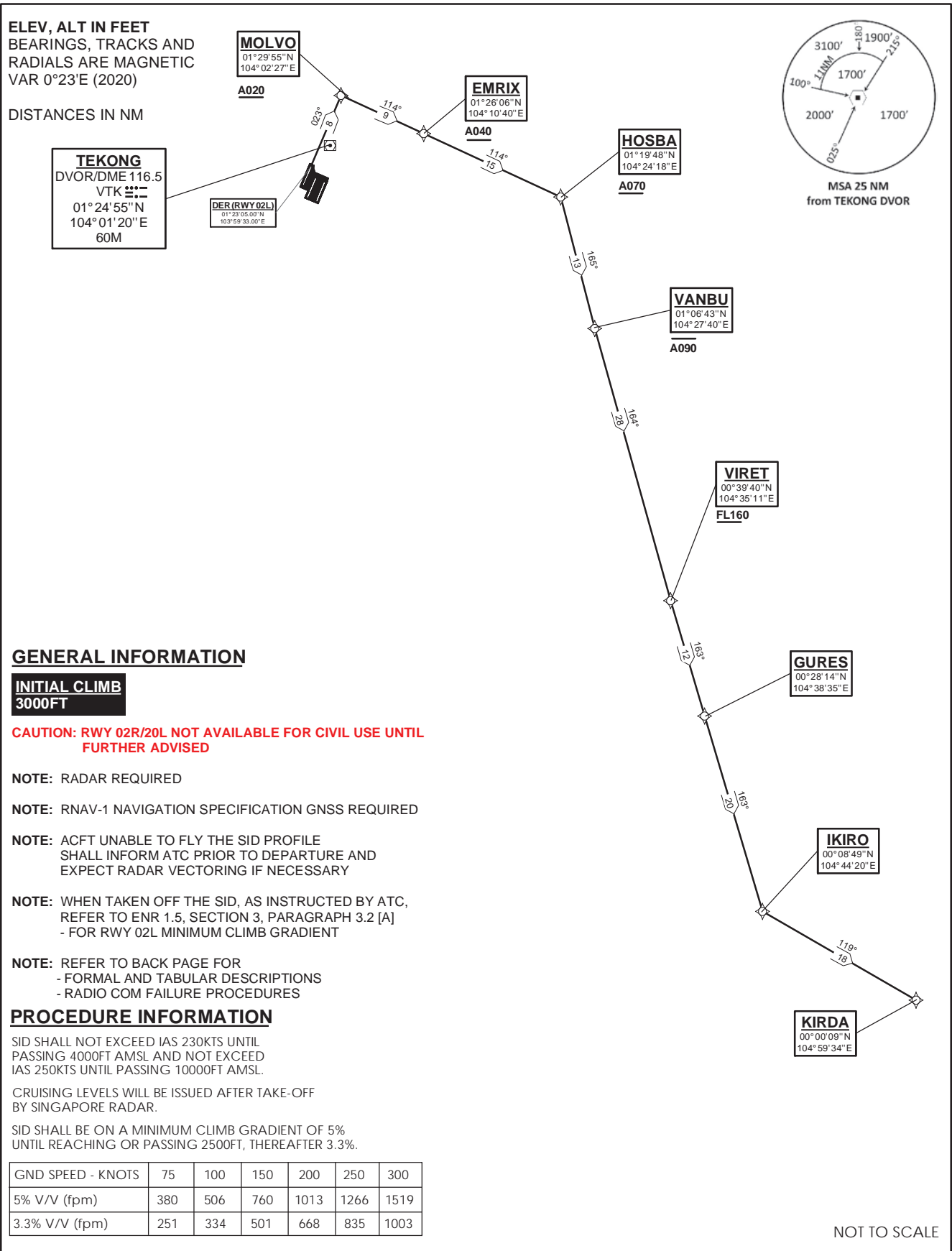

KIRDA 1E (SID) RNAV GNSS RWY 02L - DESCRIPTIONS

Formal & Abbreviated Descriptions

Formal Description	Abbreviated Description	Path Terminator	Fly-Over required
To MOLVO on course 023° at or above 2000ft, turn right.	MOLVO [M023; A020+; R] -	CF	N
To EMRIX at or above 4000ft.	EMRIX [A040+] -	TF	N
To HOSBA at or above 7000ft, turn right.	HOSBA [A070+; R] -	TF	N
To VANBU at or below 9000ft, turn left.	VANBU [A090-; L] -	TF	N
To VIRET at or above FL160, turn left.	VIRET [FL160+; L] -	TF	N
To GURES.	GURES -	TF	N
To IKIRO, turn left.	IKIRO [L] -	TF	N
To KIRDA.	KIRDA	TF	N

Tabular Descriptions

Path Term	Waypoint Name	Fly-Over	Course °M(°T)	Distance (NM)	Turn Direction	Altitude	Speed Limit	Navigation Spec
CF	MOLVO	-	023(023.4)	8.0	R	A020+	-	RNAV1
TF	EMRIX	-	114(114.4)	9.0	-	A040+	-	RNAV1
TF	HOSBA	-	114(114.4)	15.0	R	A070+	-	RNAV1
TF	VANBU	-	165(165.4)	13.0	L	A090-	-	RNAV1
TF	VIRET	-	164(164.4)	28.0	L	FL160+	-	RNAV1
TF	GURES	-	163(163.4)	12.0	-	-	-	RNAV1
TF	IKIRO	-	163(163.4)	20.0	L	-	-	RNAV1
TF	KIRDA	-	119(119.4)	18.0	-	-	-	RNAV1

Radio Communications Failure Procedure

1	SET TRANSPONDER TO MODE A/C CODE 7600
2	COMMUNICATIONS FAILURE OCCURS IMMEDIATELY AFTER DEPARTURE: PROCEED DIRECT TO NYLON HOLDING AREA (NHA) CLIMBING TO THE LAST ASSIGNED ALTITUDE, THEREAFTER REFER TO SINGAPORE AIP ON RADIO COMMUNICATIONS FAILURE PROCEDURE.

STANDARD DEPARTURE CHART
RNAV (GNSS) -
INSTRUMENT (SID)

TWR 118.6 / 118.25
APP 120.3
124.05
ACC 134.4

TRANSITION ALTITUDE
11 000ft

D-ATIS AP ID-WSSS
128.6

SINGAPORE/Singapore Changi
RWY 20R
KIRDA DEPARTURES
KIRDA 1F

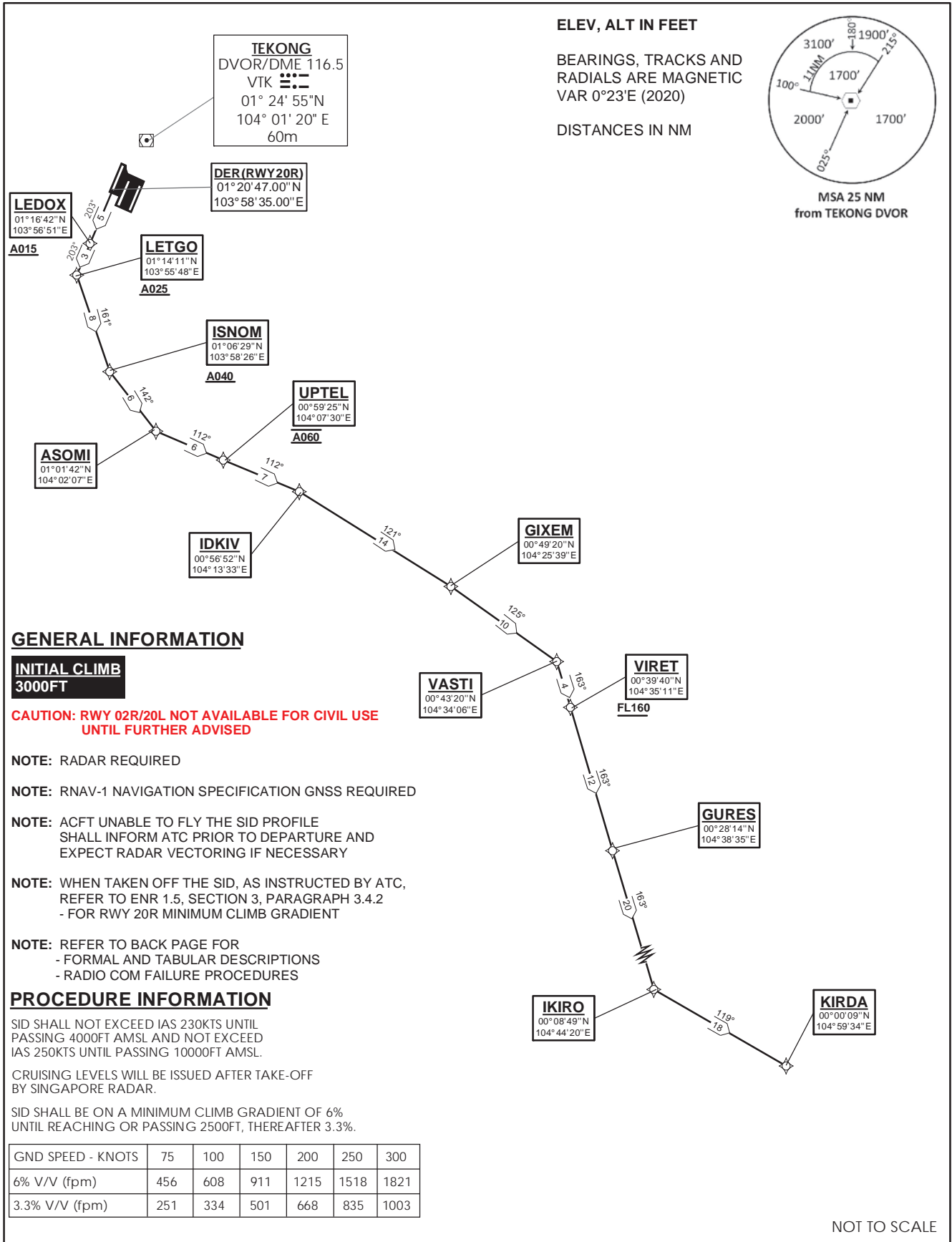

KIRDA 1F (SID) RNAV GNSS RWY 20R - DESCRIPTIONS

Formal & Abbreviated Descriptions

Formal Description	Abbreviated Description	Path Terminator	Fly-Over required
To LEDOX on course 203° at or above 1500ft.	LEDOX [M203; A015+] -	CF	N
To LETGO at or above 2500ft, turn left.	LETGO [A025+; L] -	TF	N
To ISNOM at or above 4000ft, turn left.	ISNOM [A040+; L] -	TF	N
To ASOMI, turn left.	ASOMI [L] -	TF	N
To UPTTEL at 6000ft.	UPTTEL [@A060] -	TF	N
To IDKIV, turn right.	IDKIV [R] -	TF	N
To GIXEM, turn right.	GIXEM [R] -	TF	N
To VASTI, turn right.	VASTI [R] -	TF	N
To VIRET at or above FL160.	VIRET [FL160+] -	TF	N
To GURES.	GURES -	TF	N
To IKIRO, turn left.	IKIRO [L] -	TF	N
To KIRDA.	KIRDA	TF	N

Tabular Descriptions

Path Term	Waypoint Name	Fly-Over	Course °M(°T)	Distance (NM)	Turn Direction	Altitude	Speed Limit	Navigation Spec
CF	LEDOX	-	203(203.4)	5.0	-	A015+	-	RNAV1
TF	LETGO	-	203(203.4)	3.0	L	A025+	-	RNAV1
TF	ISNOM	-	161(161.4)	8.0	L	A040+	-	RNAV1
TF	ASOMI	-	142(142.4)	6.0	L	-	-	RNAV1
TF	UPTTEL	-	112(112.4)	6.0	-	@A060	-	RNAV1
TF	IDKIV	-	112(112.4)	7.0	R	-	-	RNAV1
TF	GIXEM	-	121(121.4)	14.0	R	-	-	RNAV1
TF	VASTI	-	125(125.4)	10.0	R	-	-	RNAV1
TF	VIRET	-	163(163.4)	4.0	-	FL160+	-	RNAV1
TF	GURES	-	163(163.4)	12.0	-	-	-	RNAV1
TF	IKIRO	-	163(163.4)	20.0	L	-	-	RNAV1
TF	KIRDA	-	119(119.4)	18.0	-	-	-	RNAV1

Radio Communications Failure Procedure

1	SET TRANSPONDER TO MODE A/C CODE 7600
2	COMMUNICATIONS FAILURE OCCURS IMMEDIATELY AFTER DEPARTURE: PROCEED DIRECT TO SAMKO HOLDING AREA (SHA) CLIMBING TO THE LAST ASSIGNED ALTITUDE, THEREAFTER REFER TO SINGAPORE AIP ON RADIO COMMUNICATIONS FAILURE PROCEDURE.

STANDARD DEPARTURE CHART
RNAV (GNSS) -
INSTRUMENT (SID)

TWR 118.6 / 118.25
APP 120.3
124.05
ACC 133.25

TRANSITION ALTITUDE
11 000ft

D-ATIS AP ID-WSSS
128.6

SINGAPORE/Singapore Changi
RWY 02C
MASBO DEPARTURES
MASBO 3A

ELEV, ALT IN FEET
BEARINGS, TRACKS AND
RADIALS ARE MAGNETIC
VAR 0°23'E (2020)

DISTANCES IN NM

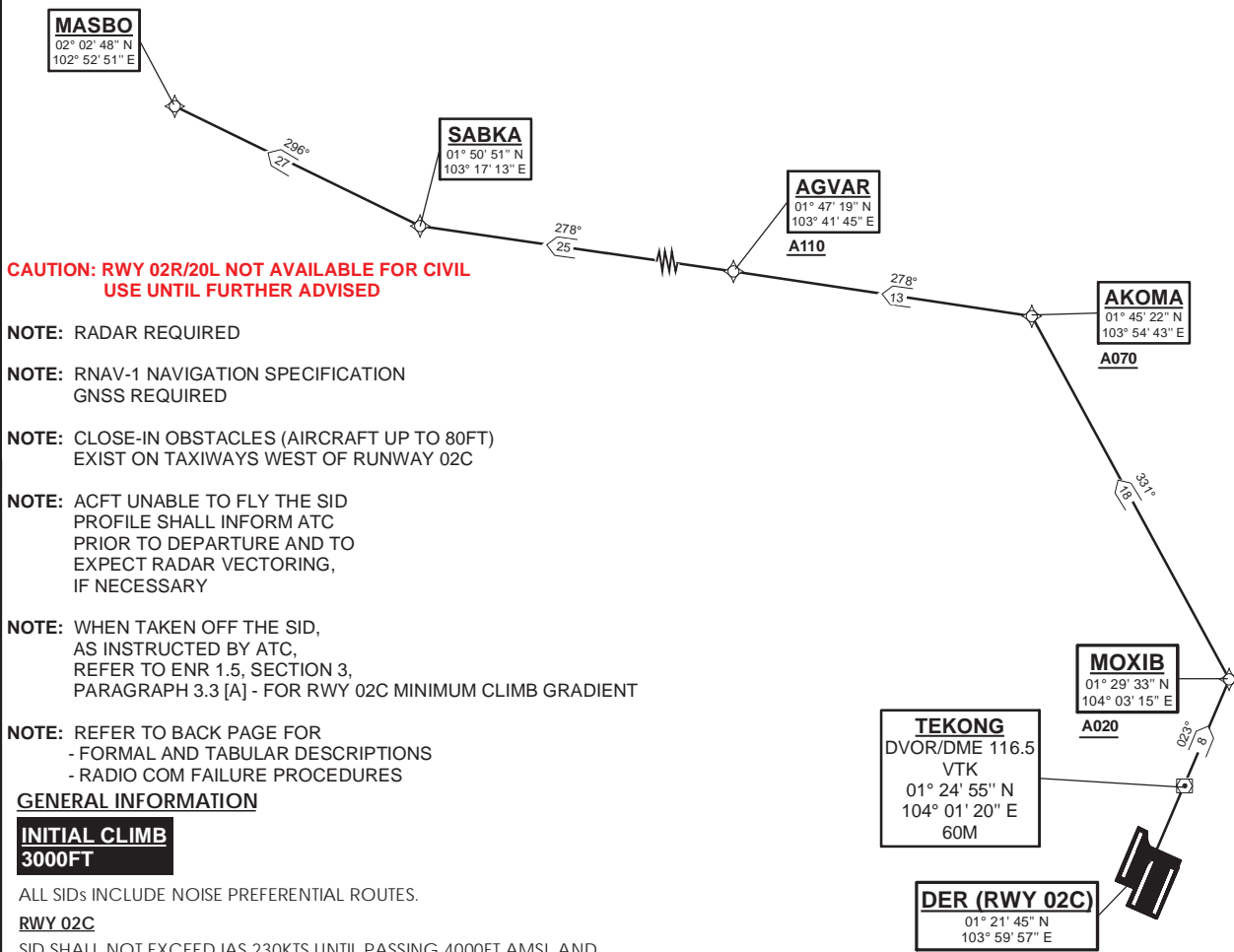
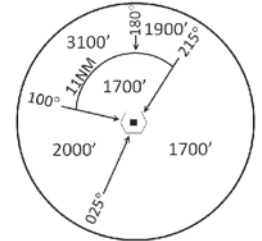

CAUTION: RWY 02R/20L NOT AVAILABLE FOR CIVIL USE UNTIL FURTHER ADVISED

- NOTE:** RADAR REQUIRED
- NOTE:** RNAV-1 NAVIGATION SPECIFICATION GNSS REQUIRED
- NOTE:** CLOSE-IN OBSTACLES (AIRCRAFT UP TO 80FT) EXIST ON TAXIWAYS WEST OF RUNWAY 02C
- NOTE:** ACFT UNABLE TO FLY THE SID PROFILE SHALL INFORM ATC PRIOR TO DEPARTURE AND TO EXPECT RADAR VECTORIZING, IF NECESSARY
- NOTE:** WHEN TAKEN OFF THE SID, AS INSTRUCTED BY ATC, REFER TO ENR 1.5, SECTION 3, PARAGRAPH 3.3 [A] - FOR RWY 02C MINIMUM CLIMB GRADIENT
- NOTE:** REFER TO BACK PAGE FOR
 - FORMAL AND TABULAR DESCRIPTIONS
 - RADIO COM FAILURE PROCEDURES

GENERAL INFORMATION

INITIAL CLIMB
3000FT

ALL SIDs INCLUDE NOISE PREFERENTIAL ROUTES.
RWY 02C
SID SHALL NOT EXCEED IAS 230KTS UNTIL PASSING 4000FT AMSL AND NOT EXCEED IAS 250KTS UNTIL PASSING 10000FT AMSL.
CRUISING LEVELS WILL BE ISSUED AFTER TAKE-OFF BY SINGAPORE RADAR.
SID SHALL BE ON A MINIMUM CLIMB GRADIENT OF 5% UNTIL REACHING OR PASSING 2500FT, THEREAFTER 3.3%.

GND SPEED - KNOTS	75	100	150	200	250	300
5% V/V (fpm)	380	506	760	1013	1266	1519
3.3% V/V (fpm)	251	334	501	668	835	1003

NOT TO SCALE

31 OCT 2024

MASBO 3A (SID) RNAV GNSS RWY 02C - DESCRIPTIONS**Formal & Abbreviated Descriptions**

Formal Description	Abbreviated Description	Path Terminator	Fly-Over required
To MOXIB on course 023° at or above 2000ft, turn left.	MOXIB [M023; A020+; L] -	CF	N
To AKOMA at or above 7000ft, turn left.	AKOMA [A070+; L] -	TF	N
To AGVAR at or above 11000ft.	AGVAR [A110+] -	TF	N
To SABKA, turn right.	SABKA [R] -	TF	N
To MASBO.	MASBO	TF	N

Tabular Descriptions

Path Term	Waypoint Name	Fly-Over	Course °M(°T)	Distance (NM)	Turn Direction	Altitude	Speed Limit	Navigation Spec
CF	MOXIB	-	023(023.4)	8.0	L	A020+	-	RNAV1
TF	AKOMA	-	331(331.4)	18.0	L	A070+	-	RNAV1
TF	AGVAR	-	278(278.4)	13.0	-	A110+	-	RNAV1
TF	SABKA	-	278(278.4)	25.0	R	-	-	RNAV1
TF	MASBO	-	296(296.4)	27.0	-	-	-	RNAV1

Radio Communications Failure Procedure

1	SET TRANSPONDER TO MODE A/C CODE 7600
2	COMMUNICATIONS FAILURE OCCURS IMMEDIATELY AFTER DEPARTURE: PROCEED DIRECT TO NYLON HOLDING AREA (NHA) CLIMBING TO THE LAST ASSIGNED ALTITUDE, THEREAFTER REFER TO SINGAPORE AIP ON RADIO COMMUNICATIONS FAILURE PROCEDURE.

STANDARD DEPARTURE CHART
RNAV (GNSS) -
INSTRUMENT (SID)

TWR 118.6 / 118.25
APP 120.3
124.05
ACC 133.25

TRANSITION ALTITUDE
11 000ft

D-ATIS AP ID-WSSS
128.6

SINGAPORE/Singapore Changi
RWY 20C
MASBO DEPARTURES
MASBO 5B

ELEV, ALT IN FEET
BEARINGS, TRACKS AND
RADIALS ARE MAGNETIC
VAR 0°23'E (2022)

NOT TO SCALE

DISTANCES IN NM

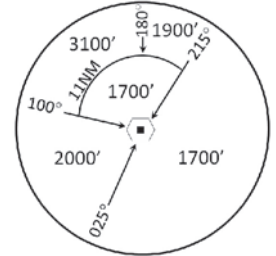

MSA 25 NM
from TEKONG DVOR

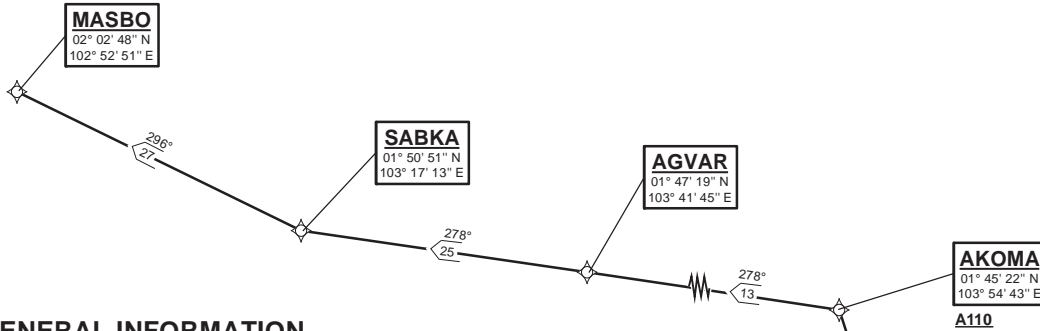

GENERAL INFORMATION

INITIAL CLIMB
3000FT

CAUTION: RWY 02R/20L NOT AVAILABLE FOR CIVIL USE UNTIL FURTHER ADVISED

NOTE: RADAR REQUIRED

NOTE: RNAV-1 NAVIGATION SPECIFICATION GNSS REQUIRED

NOTE: ACFT UNABLE TO FLY THE SID PROFILE SHALL INFORM ATC PRIOR TO DEPARTURE AND EXPECT RADAR VECTORING IF NECESSARY

NOTE: WHEN TAKEN OFF THE SID, AS INSTRUCTED BY ATC, REFER TO ENR 1.5, SECTION 3, PARAGRAPH 3.4.1 - FOR RWY 20C MINIMUM CLIMB GRADIENT

NOTE: REFER TO BACK PAGE FOR
- FORMAL AND TABULAR DESCRIPTIONS
- RADIO COM FAILURE PROCEDURES

PROCEDURE INFORMATION

SID SHALL NOT EXCEED IAS 230KTS UNTIL PASSING 4000FT AMSL AND NOT EXCEED IAS 250KTS UNTIL PASSING 10000FT AMSL.

CRUISING LEVELS WILL BE ISSUED AFTER TAKE-OFF BY SINGAPORE RADAR.

SID SHALL BE ON A MINIMUM CLIMB GRADIENT OF 7% UNTIL REACHING OR PASSING 2500FT, THEREAFTER 3.3%.

GND SPEED - KNOTS	75	100	150	200	250	300
7% V/V (fpm)	532	709	1063	1418	1772	2127
3.3% V/V (fpm)	251	334	501	668	835	1003

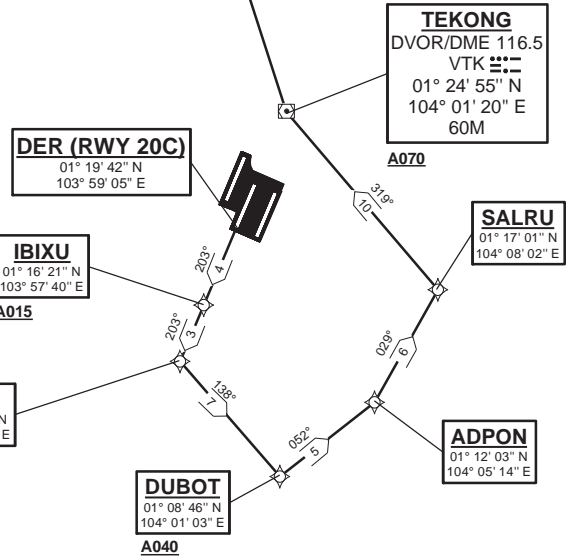

31 OCT 2024

MASBO 5B (SID) RNAV GNSS RWY 20C - DESCRIPTIONS**Formal & Abbreviated Descriptions**

Formal Description	Abbreviated Description	Path Terminator	Fly-Over required
To IBIXU on course 203° at or above 1500ft.	IBIXU [M203; A015+] -	CF	N
To IBIVA at or above 2500ft, turn left.	IBIVA [A025+; L] -	TF	N
To DUBOT at or above 4000ft, turn left.	DUBOT [A040+; L] -	TF	N
To ADPON, turn left.	ADPON [L] -	TF	N
To SALRU, turn left.	SALRU [L] -	TF	N
To VTK at or above 7000ft, turn right.	VTK [A070+; R] -	TF	N
To AKOMA at or above 11000ft, turn left.	AKOMA [A110+; L] -	TF	N
To AGVAR.	AGVAR -	TF	N
To SABKA, turn right.	SABKA [R] -	TF	N
To MASBO.	MASBO	TF	N

Tabular Descriptions

Path Term	Waypoint Name	Fly-Over	Course °M(°T)	Distance (NM)	Turn Direction	Altitude	Speed Limit	Navigation Spec
CF	IBIXU	-	203(203.4)	4.0	-	A015+	-	RNAV1
TF	IBIVA	-	203(203.4)	3.0	L	A025+	-	RNAV1
TF	DUBOT	-	138(138.4)	7.0	L	A040+	-	RNAV1
TF	ADPON	-	052(052.4)	5.0	L	-	-	RNAV1
TF	SALRU	-	029(029.4)	6.0	L	-	-	RNAV1
TF	VTK	-	319(319.4)	10.0	R	A070+	-	RNAV1
TF	AKOMA	-	342(342.4)	21.0	L	A110+	-	RNAV1
TF	AGVAR	-	278(278.4)	13.0	-	-	-	RNAV1
TF	SABKA	-	278(278.4)	25.0	R	-	-	RNAV1
TF	MASBO	-	296(296.4)	27.0	-	-	-	RNAV1

Radio Communications Failure Procedure

1	SET TRANSPONDER TO MODE A/C CODE 7600
2	COMMUNICATIONS FAILURE OCCURS IMMEDIATELY AFTER DEPARTURE: PROCEED DIRECT TO SAMKO HOLDING AREA (SHA) CLIMBING TO THE LAST ASSIGNED ALTITUDE, THEREAFTER REFER TO SINGAPORE AIP ON RADIO COMMUNICATIONS FAILURE PROCEDURE.

STANDARD DEPARTURE CHART
RNAV (GNSS) -
INSTRUMENT (SID)

TWR 118.6 / 118.25
APP 120.3
124.05
ACC 133.25

TRANSITION ALTITUDE
11 000ft

D-ATIS AP ID-WSSS
128.6

SINGAPORE/Singapore Changi
RWY 02R
MASBO DEPARTURES (RADAR)
MASBO 1C

ELEV, ALT IN FEET
BEARINGS, TRACKS AND
RADIALS ARE MAGNETIC
VAR 0°23'E (2020)

DISTANCES IN NM

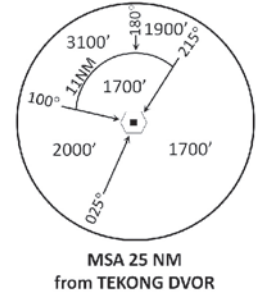

MASBO
02°02'48"N
102°52'51"E

296°
27

SABKA
01°50'51"N
103°17'13"E

278°
25

AGVAR
01°47'19"N
103°41'45"E

A110

278°
13

AKOMA
01°45'22"N
103°54'43"E

A070

GENERAL INFORMATION

INITIAL CLIMB
3000FT

CAUTION: RWY 02R/20L NOT AVAILABLE FOR CIVIL USE UNTIL FURTHER ADVISED

NOTE: RADAR REQUIRED

NOTE: RNAV-1 NAVIGATION SPECIFICATION GNSS REQUIRED

NOTE: ACFT UNABLE TO FLY THE SID PROFILE SHALL INFORM ATC PRIOR TO DEPARTURE AND EXPECT RADAR VECTORING IF NECESSARY

NOTE: WHEN TAKEN OFF THE SID, AS INSTRUCTED BY ATC, REFER TO ENR 1.5, SECTION 3, PARAGRAPH 3.5 - FOR RWY 02R MINIMUM CLIMB GRADIENT

NOTE: REFER TO BACK PAGE FOR
- FORMAL AND TABULAR DESCRIPTIONS
- RADIO COM FAILURE PROCEDURES

PROCEDURE INFORMATION

SID SHALL NOT EXCEED IAS 230KTS UNTIL PASSING 4000FT AMSL AND NOT EXCEED IAS 250KTS UNTIL PASSING 10000FT AMSL.

CRUISING LEVELS WILL BE ISSUED AFTER TAKE-OFF BY SINGAPORE RADAR.

SID SHALL BE ON A MINIMUM CLIMB GRADIENT OF 5% UNTIL REACHING OR PASSING 2500FT, THEREAFTER 3.3%.

GND SPEED - KNOTS	75	100	150	200	250	300
5% V/V (fpm)	380	506	760	1013	1266	1519
3.3% V/V (fpm)	251	334	501	668	835	1003

EXPECT RADAR vectors to waypoint AKOMA

TEKONG
DVOR/DME 116.5
VTK
01°24'55"N
104°01'20"E
60M

DER (RWY 02R)
01°21'22"N
104°00'51"E

NOT TO SCALE

MASBO 1C (SID) RNAV GNSS RWY 02R - DESCRIPTIONS

Formal & Abbreviated Descriptions

Formal Description	Abbreviated Description	Path Terminator	Fly-Over required
Climb heading 023°, Gradient 5% to 2500ft, thence 3.3%. Expect radar vectors to waypoint AKOMA.	-	VA	N
To AKOMA at or above 7000ft.	AKOMA [A070+] -	DF	N
To AGVAR at or above 11000ft.	AGVAR [A110+] -	TF	N
To SABKA, turn right.	SABKA [R] -	TF	N
To MASBO.	MASBO	TF	N

Tabular Descriptions

Path Term	Waypoint Name	Fly-Over	Course °M(°T)	Distance (NM)	Turn Direction	Altitude	Speed Limit	Navigation Spec
VA	-	-	023(023.4)	-	-	A030	-	-
DF	AKOMA	-	-	-	-	A070+	-	RNAV1
TF	AGVAR	-	278(278.4)	13.0	-	A110+	-	RNAV1
TF	SABKA	-	278(278.4)	25.0	R	-	-	RNAV1
TF	MASBO	-	296(296.4)	27.0	-	-	-	RNAV1

Radio Communications Failure Procedure

1	SET TRANSPONDER TO MODE A/C CODE 7600
2	COMMUNICATIONS FAILURE OCCURS IMMEDIATELY AFTER DEPARTURE: PROCEED DIRECT TO NYLON HOLDING AREA (NHA) CLIMBING TO THE LAST ASSIGNED ALTITUDE, THEREAFTER REFER TO SINGAPORE AIP ON RADIO COMMUNICATIONS FAILURE PROCEDURE.

STANDARD DEPARTURE CHART
RNAV (GNSS) -
INSTRUMENT (SID)

TWR 118.6 / 118.25
APP 120.3
124.05
ACC 133.25

TRANSITION ALTITUDE
11 000ft

D-ATIS AP ID-WSSS
128.6

SINGAPORE/Singapore Changi
RWY 20L
MASBO DEPARTURES
MASBO 1D

ELEV, ALT IN FEET
BEARINGS, TRACKS AND
RADIALS ARE MAGNETIC
VAR 0°23'E (2022)

NOT TO SCALE

DISTANCES IN NM

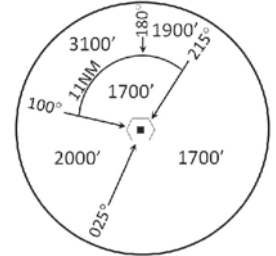

MSA 25 NM
from TEKONG DVOR

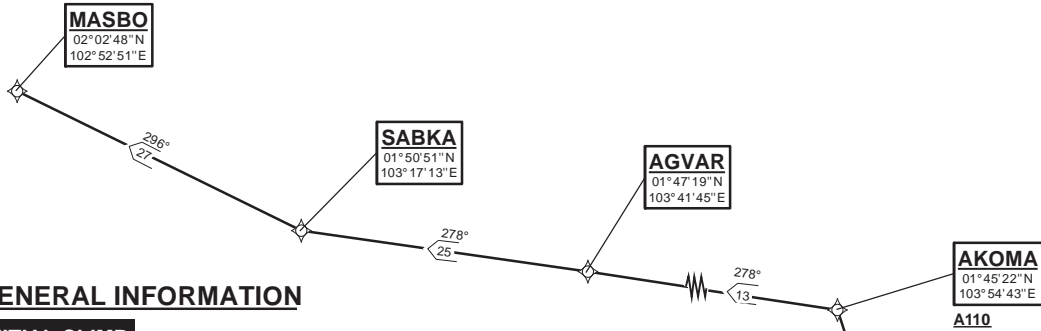

GENERAL INFORMATION

INITIAL CLIMB
3000FT

CAUTION: RWY 02R/20L NOT AVAILABLE FOR CIVIL USE UNTIL FURTHER ADVISED

NOTE: RADAR REQUIRED

NOTE: RNAV-1 NAVIGATION SPECIFICATION GNSS REQUIRED

NOTE: ACFT UNABLE TO FLY THE SID PROFILE SHALL INFORM ATC PRIOR TO DEPARTURE AND EXPECT RADAR VECTORED IF NECESSARY

NOTE: WHEN TAKEN OFF THE SID, AS INSTRUCTED BY ATC, REFER TO ENR 1.5, SECTION 3, PARAGRAPH 3.4.3 - FOR RWY 20L MINIMUM CLIMB GRADIENT

NOTE: REFER TO BACK PAGE FOR
- FORMAL AND TABULAR DESCRIPTIONS
- RADIO COM FAILURE PROCEDURES

PROCEDURE INFORMATION

SID SHALL NOT EXCEED IAS 230KTS UNTIL PASSING 4000FT AMSL AND NOT EXCEED IAS 250KTS UNTIL PASSING 10000FT AMSL.

CRUISING LEVELS WILL BE ISSUED AFTER TAKE-OFF BY SINGAPORE RADAR.

SID SHALL BE ON A MINIMUM CLIMB GRADIENT OF 9% UNTIL REACHING OR PASSING 2500FT, THEREAFTER 3.3%.

GND SPEED - KNOTS	75	100	150	200	250	300
9% V/V (fpm)	684	911	1367	1823	2279	2734
3.3% V/V (fpm)	251	334	501	668	835	1003

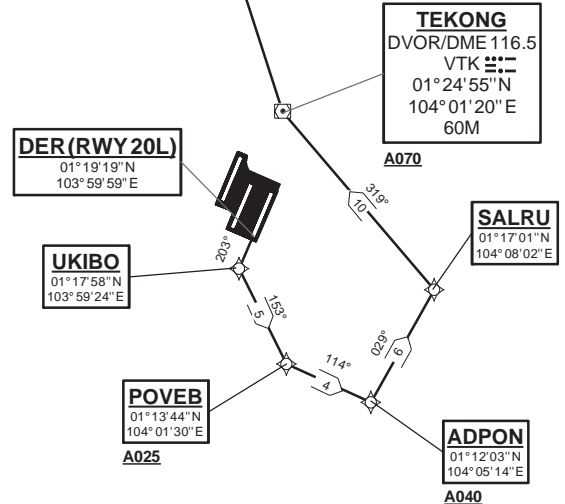

MASBO 1D (SID) RNAV GNSS RWY 20L - DESCRIPTIONS

Formal & Abbreviated Descriptions

Formal Description	Abbreviated Description	Path Terminator	Fly-Over required
To UKIBO on course 203°, turn left.	UKIBO [M203; L] -	CF	N
To POVEB at or above 2500ft, turn left.	POVEB [A025+; L] -	TF	N
To ADPON at or above 4000ft, turn left.	ADPON [A040+; L] -	TF	N
To SALRU, turn left.	SALRU [L] -	TF	N
To VTK at or above 7000ft, turn right.	VTK [A070+; R] -	TF	N
To AKOMA at or above 11000ft, turn left.	AKOMA [A110+; L] -	TF	N
To AGVAR.	AGVAR -	TF	N
To SABKA, turn right.	SABKA [R] -	TF	N
To MASBO.	MASBO	TF	N

Tabular Descriptions

Path Term	Waypoint Name	Fly-Over	Course °M(°T)	Distance (NM)	Turn Direction	Altitude	Speed Limit	Navigation Spec
CF	UKIBO	-	203(203.4)	1.5	L	-	-	RNAV1
TF	POVEB	-	153(153.4)	5.0	L	A025+	-	RNAV1
TF	ADPON	-	114(114.4)	4.0	L	A040+	-	RNAV1
TF	SALRU	-	029(029.4)	6.0	L	-	-	RNAV1
TF	VTK	-	319(319.4)	10.0	R	A070+	-	RNAV1
TF	AKOMA	-	342(342.4)	21.0	L	A110+	-	RNAV1
TF	AGVAR	-	278(278.4)	13.0	-	-	-	RNAV1
TF	SABKA	-	278(278.4)	25.0	R	-	-	RNAV1
TF	MASBO	-	296(296.4)	27.0	-	-	-	RNAV1

Radio Communications Failure Procedure

1	SET TRANSPONDER TO MODE A/C CODE 7600
2	COMMUNICATIONS FAILURE OCCURS IMMEDIATELY AFTER DEPARTURE: PROCEED DIRECT TO SAMKO HOLDING AREA (SHA) CLIMBING TO THE LAST ASSIGNED ALTITUDE, THEREAFTER REFER TO SINGAPORE AIP ON RADIO COMMUNICATIONS FAILURE PROCEDURE.

**STANDARD DEPARTURE CHART
RNAV (GNSS) -
INSTRUMENT (SID)**

TWR 118.6 / 118.25
APP 120.3
124.05
ACC 133.25

TRANSITION ALTITUDE
11 000ft

D-ATIS AP ID-WSSS
128.6

**SINGAPORE/Singapore Changi
RWY 02L
MASBO DEPARTURES
MASBO 3E**

**ELEV, ALT IN FEET
BEARINGS, TRACKS AND
RADIALS ARE MAGNETIC
VAR 0°23'E (2022)**

DISTANCES IN NM

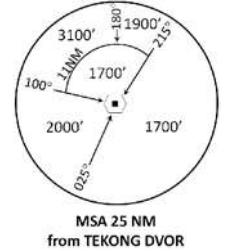

MASBO
02° 02' 48" N
102° 52' 51" E

296°
27

SABKA
01° 50' 51" N
103° 17' 13" E

278°
25

AGVAR
01° 47' 19" N
103° 41' 45" E
A110

278°
13

AKOMA
01° 45' 22" N
103° 54' 43" E
A070

323°
14

ATRUM
01° 32' 56" N
104° 00' 57" E

323°
13

MOLVO
01° 29' 55" N
104° 02' 27" E
A020

023°
8

TEKONG
DVOR/DME 116.5
VTK
01° 24' 55" N
104° 01' 20" E
60M

DER (RWY 02L)
01° 23' 05" N
103° 59' 33" E

GENERAL INFORMATION

**INITIAL CLIMB
3000FT**

CAUTION: RWY 02R/20L NOT AVAILABLE FOR CIVIL USE UNTIL FURTHER ADVISED

NOTE: RADAR REQUIRED

NOTE: RNAV-1 NAVIGATION SPECIFICATION GNSS REQUIRED

NOTE: ACFT UNABLE TO FLY THE SID PROFILE SHALL INFORM ATC PRIOR TO DEPARTURE AND EXPECT RADAR VECTORING IF NECESSARY

NOTE: WHEN TAKEN OFF THE SID, AS INSTRUCTED BY ATC, REFER TO ENR 1.5, SECTION 3, PARAGRAPH 3.2 [A] - FOR RWY 02L MINIMUM CLIMB GRADIENT

NOTE: REFER TO BACK PAGE FOR
- FORMAL AND TABULAR DESCRIPTIONS
- RADIO COM FAILURE PROCEDURES

PROCEDURE INFORMATION

SID SHALL NOT EXCEED IAS 230KTS UNTIL PASSING 4000FT AMSL AND NOT EXCEED IAS 250KTS UNTIL PASSING 10000FT AMSL.

CRUISING LEVELS WILL BE ISSUED AFTER TAKE-OFF BY SINGAPORE RADAR.

SID SHALL BE ON A MINIMUM CLIMB GRADIENT OF 5% UNTIL REACHING OR PASSING 2500FT, THEREAFTER 3.3%.

GND SPEED - KNOTS	75	100	150	200	250	300
5% V/V (fpm)	380	506	760	1013	1266	1519
3.3% V/V (fpm)	251	334	501	668	835	1003

NOT TO SCALE

MASBO 3E (SID) RNAV GNSS RWY 02L - DESCRIPTIONS

Formal & Abbreviated Descriptions

Formal Description	Abbreviated Description	Path Terminator	Fly-Over required
To MOLVO on course 023° at or above 2000ft, turn left.	MOLVO [M023; A020+; L] -	CF	N
To ATRUM.	ATRUM -	TF	N
To AKOMA at or above 7000ft, turn left.	AKOMA [A070+; L] -	TF	N
To AGVAR at or above 11000ft.	AGVAR [A110+] -	TF	N
To SABKA, turn right.	SABKA [R] -	TF	N
To MASBO.	MASBO	TF	N

Tabular Descriptions

Path Term	Waypoint Name	Fly-Over	Course °M(°T)	Distance (NM)	Turn Direction	Altitude	Speed Limit	Navigation Spec
CF	MOLVO	-	023(023.4)	8.0	L	A020+	-	RNAV1
TF	ATRUM	-	333(333.4)	3.0	-	-	-	RNAV1
TF	AKOMA	-	333(333.4)	14.0	L	A070+	-	RNAV1
TF	AGVAR	-	278(278.4)	13.0	-	A110+	-	RNAV1
TF	SABKA	-	278(278.4)	25.0	R	-	-	RNAV1
TF	MASBO	-	296(296.4)	27.0	-	-	-	RNAV1

Radio Communications Failure Procedure

1	SET TRANSPONDER TO MODE A/C CODE 7600
2	<p>COMMUNICATIONS FAILURE OCCURS IMMEDIATELY AFTER DEPARTURE:</p> <p>PROCEED DIRECT TO NYLON HOLDING AREA (NHA) CLIMBING TO THE LAST ASSIGNED ALTITUDE, THEREAFTER REFER TO SINGAPORE AIP ON RADIO COMMUNICATIONS FAILURE PROCEDURE.</p>

STANDARD DEPARTURE CHART
RNAV (GNSS) -
INSTRUMENT (SID)

TWR 118.6 / 118.25
APP 120.3
124.05
ACC 133.25

TRANSITION ALTITUDE
11 000ft

D-ATIS AP ID-WSSS
128.6

SINGAPORE/Singapore Changi
RWY 20R
MASBO DEPARTURES
MASBO 5F

ELEV, ALT IN FEET
BEARINGS, TRACKS AND
RADIALS ARE MAGNETIC
VAR 0°23'E (2022)

NOT TO SCALE

DISTANCES IN NM

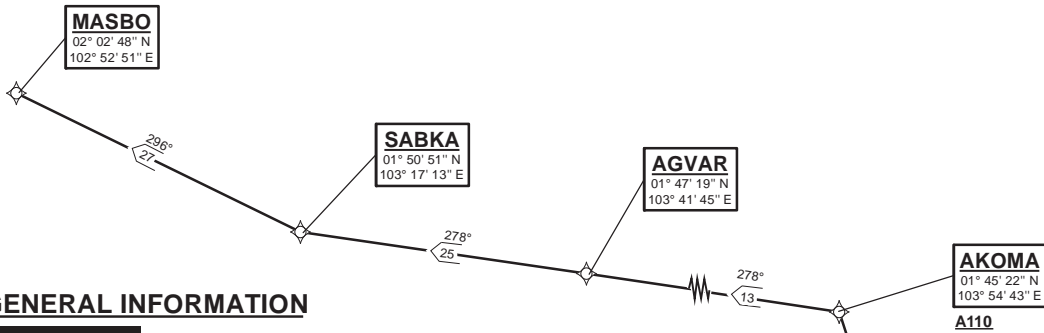
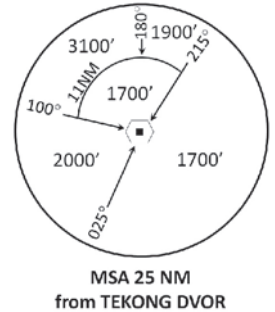

GENERAL INFORMATION

INITIAL CLIMB
3000FT

CAUTION: RWY 02R/20L NOT AVAILABLE FOR CIVIL USE UNTIL FURTHER ADVISED

NOTE: RADAR REQUIRED

NOTE: RNAV-1 NAVIGATION SPECIFICATION GNSS REQUIRED

NOTE: ACFT UNABLE TO FLY THE SID PROFILE SHALL INFORM ATC PRIOR TO DEPARTURE AND EXPECT RADAR VECTORED IF NECESSARY

NOTE: WHEN TAKEN OFF THE SID, AS INSTRUCTED BY ATC, REFER TO ENR 1.5, SECTION 3, PARAGRAPH 3.4.2 - FOR RWY 20R MINIMUM CLIMB GRADIENT

NOTE: REFER TO BACK PAGE FOR
- FORMAL AND TABULAR DESCRIPTIONS
- RADIO COM FAILURE PROCEDURES

PROCEDURE INFORMATION

SID SHALL NOT EXCEED IAS 230KTS UNTIL PASSING 4000FT AMSL AND NOT EXCEED IAS 250KTS UNTIL PASSING 10000FT AMSL.

CRUISING LEVELS WILL BE ISSUED AFTER TAKE-OFF BY SINGAPORE RADAR.

SID SHALL BE ON A MINIMUM CLIMB GRADIENT OF 6% UNTIL REACHING OR PASSING 2500FT, THEREAFTER 3.3%.

GND SPEED - KNOTS	75	100	150	200	250	300
6% V/V (fpm)	456	608	911	1215	1518	1821
3.3% V/V (fpm)	251	334	501	668	835	1003

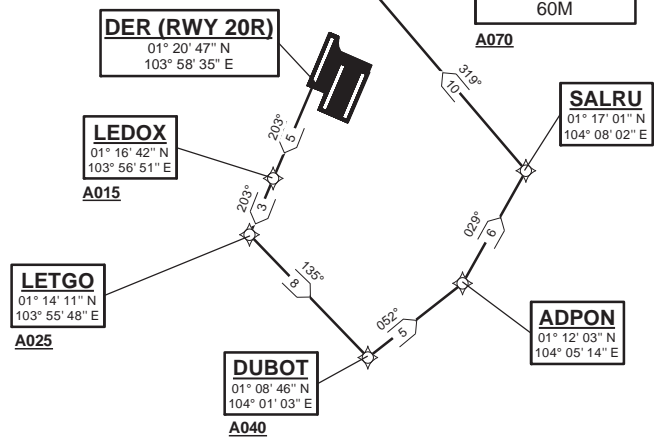

31 OCT 2024

MASBO 5F (SID) RNAV GNSS RWY 20R - DESCRIPTIONS**Formal & Abbreviated Descriptions**

Formal Description	Abbreviated Description	Path Terminator	Fly-Over required
To LEDOX on course 203° at or above 1500ft.	LEDOX [M203; A015+] -	CF	N
To LETGO at or above 2500ft, turn left.	LETGO [A025+; L] -	TF	N
To DUBOT at or above 4000ft, turn left.	DUBOT [A040+; L] -	TF	N
To ADPON, turn left.	ADPON [L] -	TF	N
To SALRU, turn left.	SALRU [L] -	TF	N
To VTK at or above 7000ft, turn right.	VTK [A070+; R] -	TF	N
To AKOMA at or above 11000ft, turn left.	AKOMA [A110+; L] -	TF	N
To AGVAR.	AGVAR -	TF	N
To SABKA, turn right.	SABKA [R] -	TF	N
To MASBO.	MASBO	TF	N

Tabular Descriptions

Path Term	Waypoint Name	Fly-Over	Course °M(°T)	Distance (NM)	Turn Direction	Altitude	Speed Limit	Navigation Spec
CF	LEDOX	-	203(203.4)	5.0	-	A015+	-	RNAV1
TF	LETGO	-	203(203.4)	3.0	L	A025+	-	RNAV1
TF	DUBOT	-	135(135.4)	8.0	L	A040+	-	RNAV1
TF	ADPON	-	052(052.4)	5.0	L	-	-	RNAV1
TF	SALRU	-	029(029.4)	6.0	L	-	-	RNAV1
TF	VTK	-	319(319.4)	10.0	R	A070+	-	RNAV1
TF	AKOMA	-	342(342.4)	21.0	L	A110+	-	RNAV1
TF	AGVAR	-	278(278.4)	13.0	-	-	-	RNAV1
TF	SABKA	-	278(278.4)	25.0	R	-	-	RNAV1
TF	MASBO	-	296(296.4)	27.0	-	-	-	RNAV1

Radio Communications Failure Procedure

1	SET TRANSPONDER TO MODE A/C CODE 7600
2	COMMUNICATIONS FAILURE OCCURS IMMEDIATELY AFTER DEPARTURE: PROCEED DIRECT TO SAMKO HOLDING AREA (SHA) CLIMBING TO THE LAST ASSIGNED ALTITUDE, THEREAFTER REFER TO SINGAPORE AIP ON RADIO COMMUNICATIONS FAILURE PROCEDURE.

STANDARD DEPARTURE CHART
RNAV (GNSS) -
INSTRUMENT (SID)

TWR 118.6 / 118.25
APP 120.3
124.05
ACC 133.8

TRANSITION ALTITUDE
11 000ft

D-ATIS AP ID-WSSS
128.6

SINGAPORE/Singapore Changi
RWY 02C
MERSING DEPARTURES
VMR 6A

ELEV, ALT IN FEET
BEARINGS, TRACKS AND
RADIALS ARE MAGNETIC
VAR 23°E (2020)

DISTANCES IN NM

VMR
02° 23' 18" N
103° 52' 18" E

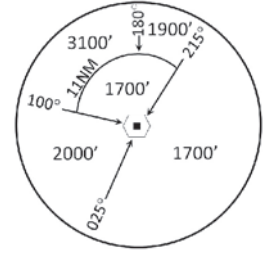

MSA 25 NM
from TEKONG DVOR

CAUTION: RWY 02R/20L NOT AVAILABLE FOR CIVIL USE UNTIL FURTHER ADVISED

NOTE: RADAR REQUIRED

NOTE: RNAV-1 NAVIGATION SPECIFICATION
GNSS REQUIRED

NOTE: CLOSE-IN OBSTACLES (AIRCRAFT UP TO 80FT)
EXIST ON TAXIWAYS WEST OF RUNWAY 02C

NOTE: ACFT UNABLE TO FLY THE SID
PROFILE SHALL INFORM ATC
PRIOR TO DEPARTURE AND TO
EXPECT RADAR VECTORING,
IF NECESSARY

NOTE: WHEN TAKEN OFF THE SID,
AS INSTRUCTED BY ATC,
REFER TO ENR 1.5, SECTION 3,
PARAGRAPH 3.3 [A] - FOR RWY 02C MINIMUM CLIMB GRADIENT

NOTE: REFER TO BACK PAGE FOR
- FORMAL AND TABULAR DESCRIPTIONS
- RADIO COM FAILURE PROCEDURES

GENERAL INFORMATION

INITIAL CLIMB
3000FT

ALL SIDS INCLUDE NOISE PREFERENTIAL ROUTES.

RWY 02C

SID SHALL NOT EXCEED IAS 230KTS UNTIL PASSING 4000FT AMSL AND NOT EXCEED IAS 250KTS UNTIL PASSING 10000FT AMSL.

CRUISING LEVELS WILL BE ISSUED AFTER TAKE-OFF BY SINGAPORE RADAR.

SID SHALL BE ON A MINIMUM CLIMB GRADIENT OF 5% UNTIL REACHING OR PASSING 2500FT, THEREAFTER 3.3%.

GND SPEED - KNOTS	75	100	150	200	250	300
5% V/V (fpm)	380	506	760	1013	1266	1519
3.3% V/V (fpm)	251	334	501	668	835	1003

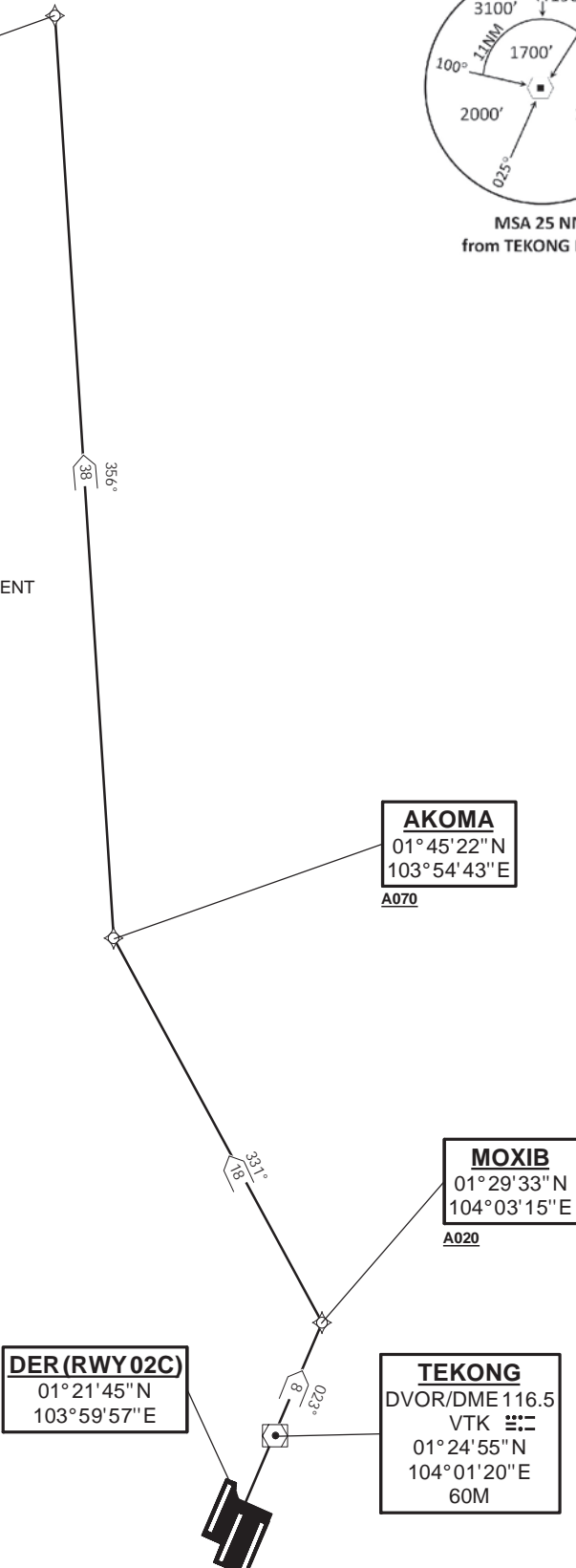

NOT TO SCALE

31 OCT 2024

VMR 6A (SID) RNAV GNSS RWY 02C - DESCRIPTIONS**Formal & Abbreviated Descriptions**

Formal Description	Abbreviated Description	Path Terminator	Fly-Over required
To MOXIB on course 023° at or above 2000ft, turn left.	MOXIB [M023; A020+; L] -	CF	N
To AKOMA at or above 7000ft, turn right.	AKOMA [A070+; R] -	TF	N
To VMR.	VMR	TF	N

Tabular Descriptions

Path Term	Waypoint Name	Fly-Over	Course °M(°T)	Distance (NM)	Turn Direction	Altitude	Speed Limit	Navigation Spec
CF	MOXIB	-	023(023.4)	8.0	L	A020+	-	RNAV1
TF	AKOMA	-	331(331.4)	18.0	R	A070+	-	RNAV1
TF	VMR	-	356(356.4)	38.0	-	-	-	RNAV1

Radio Communications Failure Procedure

1	SET TRANSPONDER TO MODE A/C CODE 7600
2	COMMUNICATIONS FAILURE OCCURS IMMEDIATELY AFTER DEPARTURE: PROCEED DIRECT TO NYLON HOLDING AREA (NHA) CLIMBING TO THE LAST ASSIGNED ALTITUDE, THEREAFTER REFER TO SINGAPORE AIP ON RADIO COMMUNICATIONS FAILURE PROCEDURE.

STANDARD DEPARTURE CHART
RNAV (GNSS) -
INSTRUMENT (SID)

TWR 118.6 / 118.25 APP 120.3 124.05 ACC 133.8	TRANSITION ALTITUDE 11 000ft
	D-ATIS AP ID-WSSS 128.6

SINGAPORE/Singapore Changi
RWY 20C
MERSING DEPARTURES
VMR 9B

ELEV, ALT IN FEET
BEARINGS, TRACKS AND
RADIALS ARE MAGNETIC
VAR 0°23'E (2022)

DISTANCES IN NM

GENERAL INFORMATION

INITIAL CLIMB
3000FT

CAUTION: RWY 02R/20L NOT AVAILABLE FOR CIVIL USE UNTIL FURTHER ADVISED

NOTE: RADAR REQUIRED

NOTE: RNAV-1 NAVIGATION SPECIFICATION GNSS REQUIRED

NOTE: ACFT UNABLE TO FLY THE SID PROFILE
SHALL INFORM ATC PRIOR TO DEPARTURE AND
EXPECT RADAR VECTORING IF NECESSARY

NOTE: WHEN TAKEN OFF THE SID, AS INSTRUCTED BY ATC,
REFER TO ENR 1.5, SECTION 3, PARAGRAPH 3.4.1
- FOR RWY 20C MINIMUM CLIMB GRADIENT

NOTE: REFER TO BACK PAGE FOR
- FORMAL AND TABULAR DESCRIPTIONS
- RADIO COM FAILURE PROCEDURES

PROCEDURE INFORMATION

SID SHALL NOT EXCEED IAS 230KTS UNTIL
PASSING 4000FT AMSL AND NOT EXCEED
IAS 250KTS UNTIL PASSING 10000FT AMSL

CRUISING LEVELS WILL BE ISSUED AFTER TAKE-OFF
BY SINGAPORE RADAR.

SID SHALL BE ON A MINIMUM CLIMB GRADIENT OF 7%
UNTIL REACHING OR PASSING 2500FT, THEREAFTER 3.3%.

GND SPEED - KNOTS	75	100	150	200	250	300
7% V/V (fpm)	532	709	1063	1418	1772	2127
3.3% V/V (fpm)	251	334	501	668	835	1003

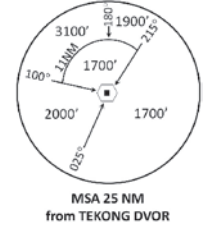

NOT TO SCALE

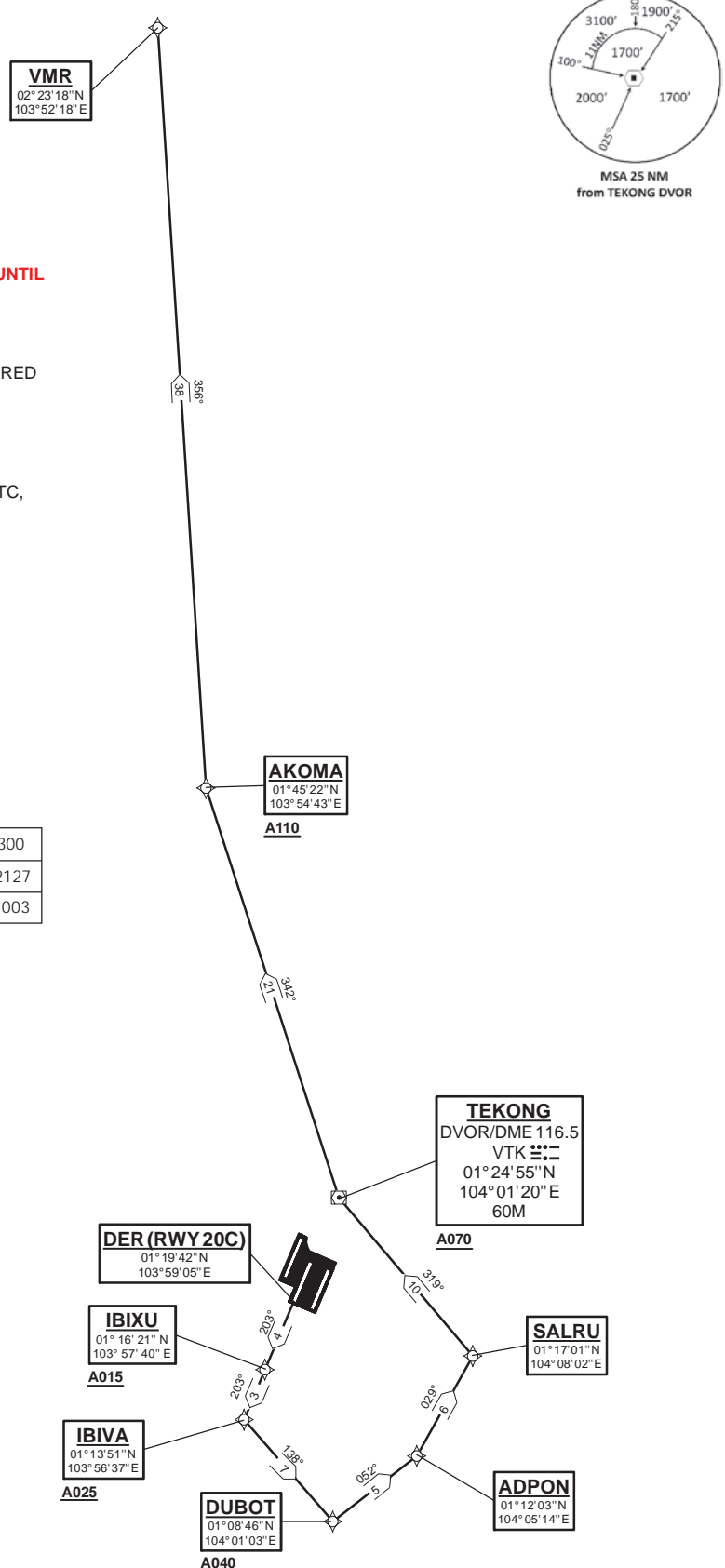

VMR 9B (SID) RNAV GNSS RWY 20C - DESCRIPTIONS

Formal & Abbreviated Descriptions

Formal Description	Abbreviated Description	Path Terminator	Fly-Over required
To IBIXU on course 203° at or above 1500ft.	IBIXU [M203; A015+] -	CF	N
To IBIVA at or above 2500ft, turn left.	IBIVA [A025+; L] -	TF	N
To DUBOT at or above 4000ft, turn left.	DUBOT [A040+; L] -	TF	N
To ADPON, turn left.	ADPON [L] -	TF	N
To SALRU, turn left.	SALRU [L] -	TF	N
To VTK at or above 7000ft, turn right.	VTK [A070+; R] -	TF	N
To AKOMA at or above 11000ft, turn right.	AKOMA [A110+; R] -	TF	N
To VMR.	VMR	TF	N

Tabular Descriptions

Path Term	Waypoint Name	Fly-Over	Course °M(°T)	Distance (NM)	Turn Direction	Altitude	Speed Limit	Navigation Spec
CF	IBIXU	-	203(203.4)	4.0	-	A015+	-	RNAV1
TF	IBIVA	-	203(203.4)	3.0	L	A025+	-	RNAV1
TF	DUBOT	-	138(138.4)	7.0	L	A040+	-	RNAV1
TF	ADPON	-	052(052.4)	5.0	L	-	-	RNAV1
TF	SALRU	-	029(029.4)	6.0	L	-	-	RNAV1
TF	VTK	-	319(319.4)	10.0	R	A070+	-	RNAV1
TF	AKOMA	-	342(342.4)	21.0	R	A110+	-	RNAV1
TF	VMR	-	356(356.4)	38.0	-	-	-	RNAV1

Radio Communications Failure Procedure

1	SET TRANSPONDER TO MODE A/C CODE 7600
2	<p>COMMUNICATIONS FAILURE OCCURS IMMEDIATELY AFTER DEPARTURE:</p> <p>PROCEED DIRECT TO SAMKO HOLDING AREA (SHA) CLIMBING TO THE LAST ASSIGNED ALTITUDE, THEREAFTER REFER TO SINGAPORE AIP ON RADIO COMMUNICATIONS FAILURE PROCEDURE.</p>

STANDARD DEPARTURE CHART
RNAV (GNSS) -
INSTRUMENT (SID)

TWR 118.6 / 118.25
APP 120.3
124.05
ACC 133.8

TRANSITION ALTITUDE
11 000ft

D-ATIS AP ID-WSSS
128.6

SINGAPORE/Singapore Changi
RWY 02R
MERSING DEPARTURES (RADAR)
VMR 1C

ELEV, ALT IN FEET
BEARINGS, TRACKS AND
RADIALS ARE MAGNETIC
VAR 23°E (2020)

DISTANCES IN NM

VMR
02°23'18"N
103°52'18"E

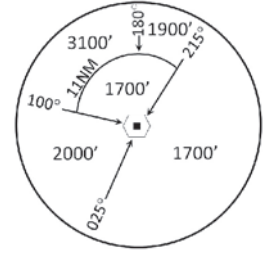

GENERAL INFORMATION

INITIAL CLIMB
3000FT

CAUTION: RWY 02R/20L NOT AVAILABLE FOR CIVIL USE UNTIL FURTHER ADVISED

NOTE: RADAR REQUIRED

NOTE: RNAV-1 NAVIGATION SPECIFICATION GNSS REQUIRED

NOTE: ACFT UNABLE TO FLY THE SID PROFILE
SHALL INFORM ATC PRIOR TO DEPARTURE AND
EXPECT RADAR VECTORING IF NECESSARY

NOTE: WHEN TAKEN OFF THE SID, AS INSTRUCTED BY ATC,
REFER TO ENR 1.5, SECTION 3, PARAGRAPH 3.5
- FOR RWY 02R MINIMUM CLIMB GRADIENT

NOTE: REFER TO BACK PAGE FOR
- FORMAL AND TABULAR DESCRIPTIONS
- RADIO COM FAILURE PROCEDURES

PROCEDURE INFORMATION

SID SHALL NOT EXCEED IAS 230KTS UNTIL
PASSING 4000FT AMSL AND NOT EXCEED
IAS 250KTS UNTIL PASSING 10000FT AMSL.

CRUISING LEVELS WILL BE ISSUED AFTER TAKE-OFF
BY SINGAPORE RADAR.

SID SHALL BE ON A MINIMUM CLIMB GRADIENT OF 5%
UNTIL REACHING OR PASSING 2500FT, THEREAFTER 3.3%.

GND SPEED - KNOTS	75	100	150	200	250	300
5% V/V (fpm)	380	506	760	1013	1266	1519
3.3% V/V (fpm)	251	334	501	668	835	1003



AKOMA
01°45'22"N
103°54'43"E
A070

EXPECT RADAR vectors
to waypoint AKOMA

TEKONG
DVOR/DME 116.5
VTK
01°24'55"N
104°01'20"E
60M

DER (RWY 02R)
01°21'22"N
104°00'51"E

NOT TO SCALE

31 OCT 2024

VMR 1C (SID) RNAV GNSS RWY 02R - DESCRIPTIONS**Formal & Abbreviated Descriptions**

Formal Description	Abbreviated Description	Path Terminator	Fly-Over required
Climb heading 023°, Gradient 5% to 2500ft, thence 3.3%. Expect radar vectors to waypoint AKOMA.	-	VA	N
To AKOMA at or above 7000ft.	AKOMA [A070+] -	DF	N
To VMR.	VMR	TF	N

Tabular Descriptions

Path Term	Waypoint Name	Fly-Over	Course °M(°T)	Distance (NM)	Turn Direction	Altitude	Speed Limit	Navigation Spec
VA	-	-	023(023.4)	-	-	A030	-	-
DF	AKOMA	-	-	-	-	A070+	-	RNAV1
TF	VMR	-	356(356.4)	38.0	-	-	-	RNAV1

Radio Communications Failure Procedure

1	SET TRANSPONDER TO MODE A/C CODE 7600
2	COMMUNICATIONS FAILURE OCCURS IMMEDIATELY AFTER DEPARTURE: PROCEED DIRECT TO NYLON HOLDING AREA (NHA) CLIMBING TO THE LAST ASSIGNED ALTITUDE, THEREAFTER REFER TO SINGAPORE AIP ON RADIO COMMUNICATIONS FAILURE PROCEDURE.

STANDARD DEPARTURE CHART
RNAV (GNSS) -
INSTRUMENT (SID)

TWR 118.6 / 118.25
APP 120.3
124.05
ACC 133.8

TRANSITION ALTITUDE
11 000ft

D-ATIS AP ID-WSSS
128.6

SINGAPORE/Singapore Changi
RWY 20L
MERSING DEPARTURES
VMR 1D

ELEV, ALT IN FEET
BEARINGS, TRACKS AND
RADIALS ARE MAGNETIC
VAR 0°23'E (2022)

DISTANCES IN NM

GENERAL INFORMATION

INITIAL CLIMB
3000FT

CAUTION: RWY 02R/20L NOT AVAILABLE FOR CIVIL USE UNTIL FURTHER ADVISED

NOTE: RADAR REQUIRED

NOTE: RNAV-1 NAVIGATION SPECIFICATION GNSS REQUIRED

NOTE: ACFT UNABLE TO FLY THE SID PROFILE SHALL INFORM ATC PRIOR TO DEPARTURE AND EXPECT RADAR VECTORED IF NECESSARY

NOTE: WHEN TAKEN OFF THE SID, AS INSTRUCTED BY ATC, REFER TO ENR 1.5, SECTION 3, PARAGRAPH 3.4.3 - FOR RWY 20L MINIMUM CLIMB GRADIENT

NOTE: REFER TO BACK PAGE FOR
- FORMAL AND TABULAR DESCRIPTIONS
- RADIO COM FAILURE PROCEDURES

PROCEDURE INFORMATION

SID SHALL NOT EXCEED IAS 230KTS UNTIL PASSING 4000FT AMSL AND NOT EXCEED IAS 250KTS UNTIL PASSING 10000FT AMSL.

CRUISING LEVELS WILL BE ISSUED AFTER TAKE-OFF BY SINGAPORE RADAR.

SID SHALL BE ON A MINIMUM CLIMB GRADIENT OF 9% UNTIL REACHING OR PASSING 2500FT, THEREAFTER 3.3%.

GND SPEED - KNOTS	75	100	150	200	250	300
9% V/V (fpm)	684	911	1367	1823	2279	2734
3.3% V/V (fpm)	251	334	501	668	835	1003

VMR
02°23'18"N
103°52'18"E

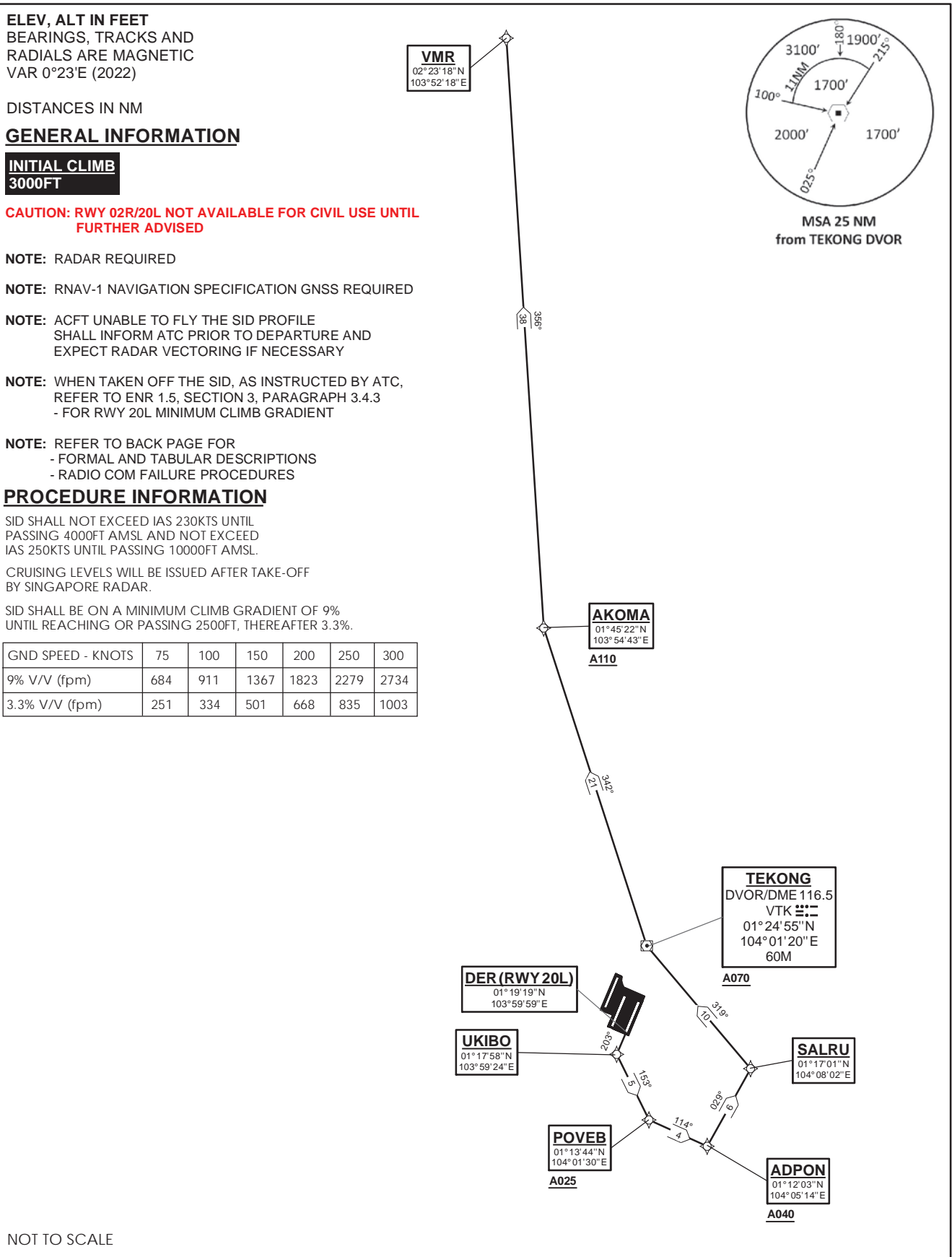
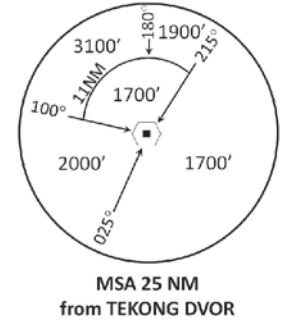

NOT TO SCALE

VMR 1D (SID) RNAV GNSS RWY 20L - DESCRIPTIONS

Formal & Abbreviated Descriptions

Formal Description	Abbreviated Description	Path Terminator	Fly-Over required
To UKIBO on course 203°, turn left.	UKIBO [M203; L] -	CF	N
To POVEB at or above 2500ft, turn left.	POVEB [A025+; L] -	TF	N
To ADPON at or above 4000ft, turn left.	ADPON [A040+; L] -	TF	N
To SALRU, turn left.	SALRU [L] -	TF	N
To VTK at or above 7000ft, turn right.	VTK [A070+; R] -	TF	N
To AKOMA at or above 11000ft, turn right.	AKOMA [A110+; R] -	TF	N
To VMR.	VMR	TF	N

Tabular Descriptions

Path Term	Waypoint Name	Fly-Over	Course °M(°T)	Distance (NM)	Turn Direction	Altitude	Speed Limit	Navigation Spec
CF	UKIBO	-	203(203.4)	1.5	L	-	-	RNAV1
TF	POVEB	-	153(153.4)	5.0	L	A025+	-	RNAV1
TF	ADPON	-	114(114.4)	4.0	L	A040+	-	RNAV1
TF	SALRU	-	029(029.4)	6.0	L	-	-	RNAV1
TF	VTK	-	319(319.4)	10.0	R	A070+	-	RNAV1
TF	AKOMA	-	342(342.4)	21.0	R	A110+	-	RNAV1
TF	VMR	-	356(356.4)	38.0	-	-	-	RNAV1

Radio Communications Failure Procedure

1	SET TRANSPONDER TO MODE A/C CODE 7600
2	<p>COMMUNICATIONS FAILURE OCCURS IMMEDIATELY AFTER DEPARTURE:</p> <p>PROCEED DIRECT TO SAMKO HOLDING AREA (SHA) CLIMBING TO THE LAST ASSIGNED ALTITUDE, THEREAFTER REFER TO SINGAPORE AIP ON RADIO COMMUNICATIONS FAILURE PROCEDURE.</p>

STANDARD DEPARTURE CHART
RNAV (GNSS) -
INSTRUMENT (SID)

TWR 118.6 / 118.25
APP 120.3
124.05
ACC 133.8

TRANSITION ALTITUDE
11 000ft

D-ATIS AP ID-WSSS
128.6

SINGAPORE/Singapore Changi
RWY 02L
MERSING DEPARTURES
VMR 6E

ELEV, ALT IN FEET
BEARINGS, TRACKS AND
RADIALS ARE MAGNETIC
VAR 0°23'E (2020)

DISTANCES IN NM

GENERAL INFORMATION

INITIAL CLIMB
3000FT

CAUTION: RWY 02R/20L NOT AVAILABLE FOR CIVIL USE UNTIL FURTHER ADVISED

NOTE: RADAR REQUIRED

NOTE: RNAV-1 NAVIGATION SPECIFICATION GNSS REQUIRED

NOTE: ACFT UNABLE TO FLY THE SID PROFILE SHALL INFORM ATC PRIOR TO DEPARTURE AND EXPECT RADAR VECTORING IF NECESSARY

NOTE: WHEN TAKEN OFF THE SID, AS INSTRUCTED BY ATC, REFER TO ENR 1.5, SECTION 3, PARAGRAPH 3.2 [A] - FOR RWY 02L MINIMUM CLIMB GRADIENT

NOTE: REFER TO BACK PAGE FOR
- FORMAL AND TABULAR DESCRIPTIONS
- RADIO COM FAILURE PROCEDURES

PROCEDURE INFORMATION

SID SHALL NOT EXCEED IAS 230KTS UNTIL PASSING 4000FT AMSL AND NOT EXCEED IAS 250KTS UNTIL PASSING 10000FT AMSL.

CRUISING LEVELS WILL BE ISSUED AFTER TAKE-OFF BY SINGAPORE RADAR.

SID SHALL BE ON A MINIMUM CLIMB GRADIENT OF 5% UNTIL REACHING OR PASSING 2500FT, THEREAFTER 3.3%.

GND SPEED - KNOTS	75	100	150	200	250	300
5% V/V (fpm)	380	506	760	1013	1266	1519
3.3% V/V (fpm)	251	334	501	668	835	1003

VMR
02° 23' 18" N
103° 52' 18" E

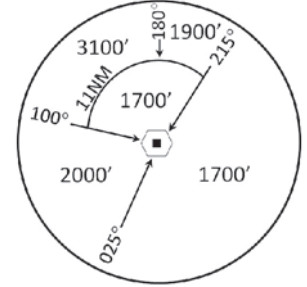

MSA 25 NM
from TEKONG DVOR

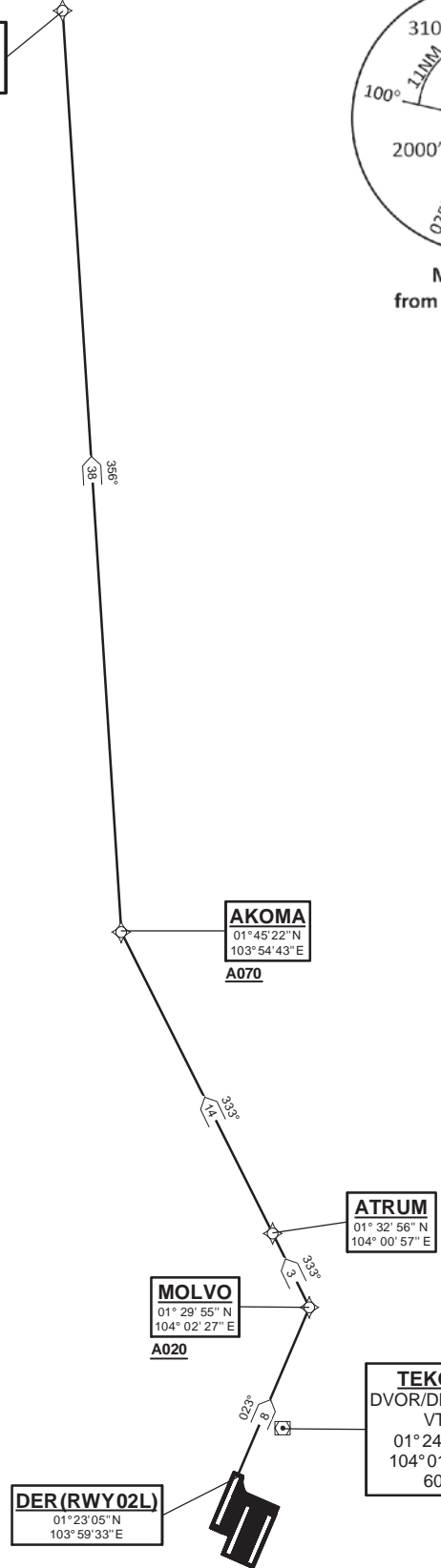

NOT TO SCALE

31 OCT 2024

VMR 6E (SID) RNAV GNSS RWY 02L - DESCRIPTIONS**Formal & Abbreviated Descriptions**

Formal Description	Abbreviated Description	Path Terminator	Fly-Over required
To MOLVO on course 023° at or above 2000ft, turn left.	MOLVO [M023; A020+; L] -	CF	N
To ATRUM.	ATRUM -	TF	N
To AKOMA at or above 7000ft, turn right.	AKOMA [A070+; R] -	TF	N
To VMR.	VMR	TF	N

Tabular Descriptions

Path Term	Waypoint Name	Fly-Over	Course °M(°T)	Distance (NM)	Turn Direction	Altitude	Speed Limit	Navigation Spec
CF	MOLVO	-	023(023.4)	8.0	L	A020+	-	RNAV1
TF	ATRUM	-	333(333.4)	3.0	-	-	-	RNAV1
TF	AKOMA	-	333(333.4)	14.0	R	A070+	-	RNAV1
TF	VMR	-	356(356.4)	38.0	-	-	-	RNAV1

Radio Communications Failure Procedure

1	SET TRANSPONDER TO MODE A/C CODE 7600
2	COMMUNICATIONS FAILURE OCCURS IMMEDIATELY AFTER DEPARTURE: PROCEED DIRECT TO NYLON HOLDING AREA (NHA) CLIMBING TO THE LAST ASSIGNED ALTITUDE, THEREAFTER REFER TO SINGAPORE AIP ON RADIO COMMUNICATIONS FAILURE PROCEDURE.

STANDARD DEPARTURE CHART
RNAV (GNSS) -
INSTRUMENT (SID)

TWR 118.6 / 118.25
APP 120.3
124.05
ACC 133.8

TRANSITION ALTITUDE
11 000ft

D-ATIS AP ID-WSSS
128.6

SINGAPORE/Singapore Changi
RWY 20R
MERSING DEPARTURES
VMR 9F

ELEV, ALT IN FEET
BEARINGS, TRACKS AND
RADIALS ARE MAGNETIC
VAR 0°23'E (2022)

DISTANCES IN NM

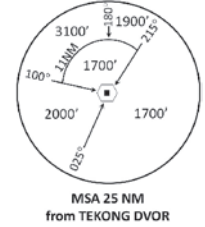

GENERAL INFORMATION

INITIAL CLIMB
3000FT

CAUTION: RWY 02R/20L NOT AVAILABLE FOR CIVIL USE UNTIL FURTHER ADVISED

NOTE: RADAR REQUIRED

NOTE: RNAV-1 NAVIGATION SPECIFICATION GNSS REQUIRED

NOTE: ACFT UNABLE TO FLY THE SID PROFILE SHALL INFORM ATC PRIOR TO DEPARTURE AND EXPECT RADAR VECTORED IF NECESSARY

NOTE: WHEN TAKEN OFF THE SID, AS INSTRUCTED BY ATC, REFER TO ENR 1.5, SECTION 3, PARAGRAPH 3.4.2 - FOR RWY 20R MINIMUM CLIMB GRADIENT

NOTE: REFER TO BACK PAGE FOR
- FORMAL AND TABULAR DESCRIPTIONS
- RADIO COM FAILURE PROCEDURES

PROCEDURE INFORMATION

SID SHALL NOT EXCEED IAS 230KTS UNTIL PASSING 4000FT AMSL AND NOT EXCEED IAS 250KTS UNTIL PASSING 10000FT AMSL.

CRUISING LEVELS WILL BE ISSUED AFTER TAKE-OFF BY SINGAPORE RADAR.

SID SHALL BE ON A MINIMUM CLIMB GRADIENT OF 6% UNTIL REACHING OR PASSING 2500FT, THEREAFTER 3.3%.

GND SPEED - KNOTS	75	100	150	200	250	300
6% V/V (fpm)	456	608	911	1215	1518	1821
3.3% V/V (fpm)	251	334	501	668	835	1003

NOT TO SCALE

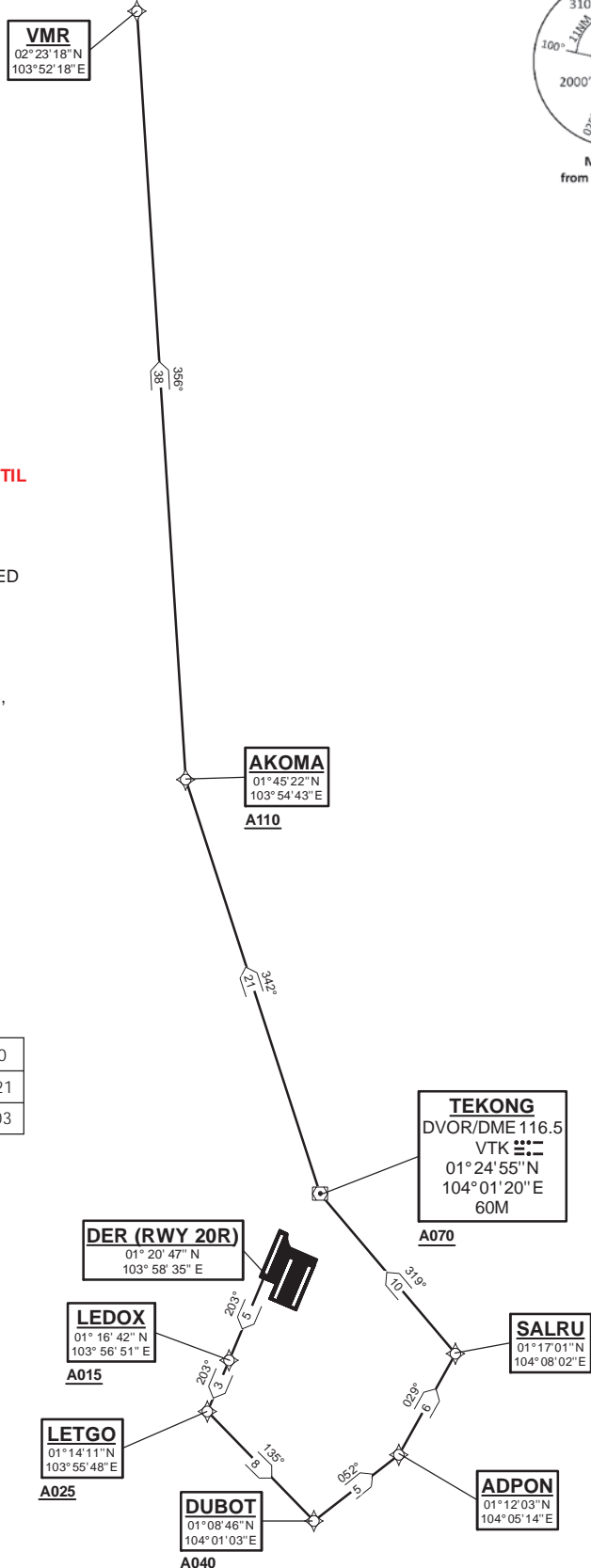

31 OCT 2024

VMR 9F (SID) RNAV GNSS RWY 20R - DESCRIPTIONS**Formal & Abbreviated Descriptions**

Formal Description	Abbreviated Description	Path Terminator	Fly-Over required
To LEDOX on course 203° at or above 1500ft.	LEDOX [M203; A015+] -	CF	N
To LETGO at or above 2500ft, turn left.	LETGO [A025+; L] -	TF	N
To DUBOT at or above 4000ft, turn left.	DUBOT [A040+; L] -	TF	N
To ADPON, turn left.	ADPON [L] -	TF	N
To SALRU, turn left.	SALRU [L] -	TF	N
To VTK at or above 7000ft, turn right.	VTK [A070+; R] -	TF	N
To AKOMA at or above 11000ft, turn right.	AKOMA [A110+; R] -	TF	N
To VMR.	VMR	TF	N

Tabular Descriptions

Path Term	Waypoint Name	Fly-Over	Course °M(°T)	Distance (NM)	Turn Direction	Altitude	Speed Limit	Navigation Spec
CF	LEDOX	-	203(203.4)	5.0	-	A015+	-	RNAV1
TF	LETGO	-	203(203.4)	3.0	L	A025+	-	RNAV1
TF	DUBOT	-	135(135.4)	8.0	L	A040+	-	RNAV1
TF	ADPON	-	052(052.4)	5.0	L	-	-	RNAV1
TF	SALRU	-	029(029.4)	6.0	L	-	-	RNAV1
TF	VTK	-	319(319.4)	10.0	R	A070+	-	RNAV1
TF	AKOMA	-	342(342.4)	21.0	R	A110+	-	RNAV1
TF	VMR	-	356(356.4)	38.0	-	-	-	RNAV1

Radio Communications Failure Procedure

1	SET TRANSPONDER TO MODE A/C CODE 7600
2	COMMUNICATIONS FAILURE OCCURS IMMEDIATELY AFTER DEPARTURE: PROCEED DIRECT TO SAMKO HOLDING AREA (SHA) CLIMBING TO THE LAST ASSIGNED ALTITUDE, THEREAFTER REFER TO SINGAPORE AIP ON RADIO COMMUNICATIONS FAILURE PROCEDURE.

STANDARD DEPARTURE CHART
RNAV (GNSS) -
INSTRUMENT (SID)

TWR 118.6 / 118.25
APP 120.3
124.05
ACC 133.25

TRANSITION ALTITUDE
11 000ft

D-ATIS AP ID-WSSS
128.6

SINGAPORE/Singapore Changi
RWY 02C
MIBEL DEPARTURES
MIBEL 1A

ELEV, ALT IN FEET

BEARINGS, TRACKS AND
RADIALS ARE MAGNETIC
VAR 0°23'E (2020)

DISTANCES IN NM

GENERAL INFORMATION

INITIAL CLIMB
3000FT

CAUTION: RWY 02R/20L NOT AVAILABLE FOR CIVIL USE UNTIL FURTHER ADVISED

NOTE: RADAR REQUIRED

NOTE: RNAV-1 NAVIGATION SPECIFICATION
GNSS REQUIRED

NOTE: CLOSE-IN OBSTACLES (AIRCRAFT UP TO 80FT)
EXIST ON TAXIWAYS WEST OF RUNWAY 02C

NOTE: ACFT UNABLE TO FLY THE SID
PROFILE SHALL INFORM ATC
PRIOR TO DEPARTURE AND TO
EXPECT RADAR VECTORING,
IF NECESSARY

NOTE: WHEN TAKEN OFF THE SID,
AS INSTRUCTED BY ATC,
REFER TO ENR 1.5, SECTION 3,
PARAGRAPH 3.3 [A] - FOR RWY 02C MINIMUM CLIMB GRADIENT

NOTE: REFER TO BACK PAGE FOR
- FORMAL AND TABULAR DESCRIPTIONS
- RADIO COM FAILURE PROCEDURES

PROCEDURE INFORMATION

SID SHALL NOT EXCEED IAS 230KTS UNTIL PASSING 4000FT AMSL AND
NOT EXCEED IAS 250KTS UNTIL PASSING 10000FT AMSL.

CRUISING LEVELS WILL BE ISSUED AFTER TAKE-OFF
BY SINGAPORE RADAR.

SID SHALL BE ON A MINIMUM CLIMB GRADIENT OF 5%
UNTIL REACHING OR PASSING 2500FT, THEREAFTER 3.3%.

GND SPEED - KNOTS	75	100	150	200	250	300
5% V/V (fpm)	380	506	760	1013	1266	1519
3.3% V/V (fpm)	251	334	501	668	835	1003

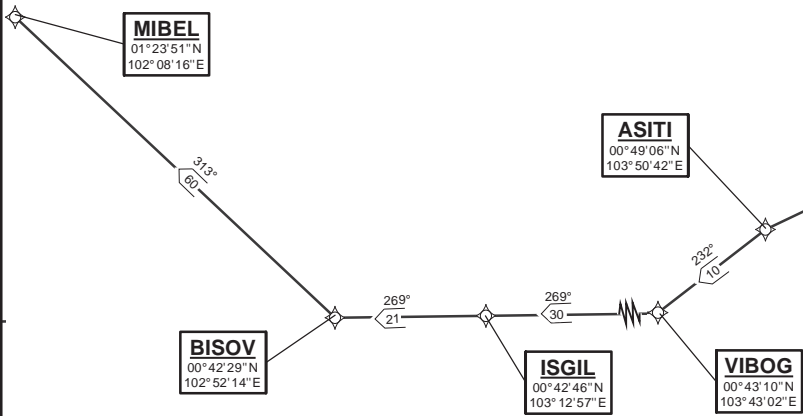
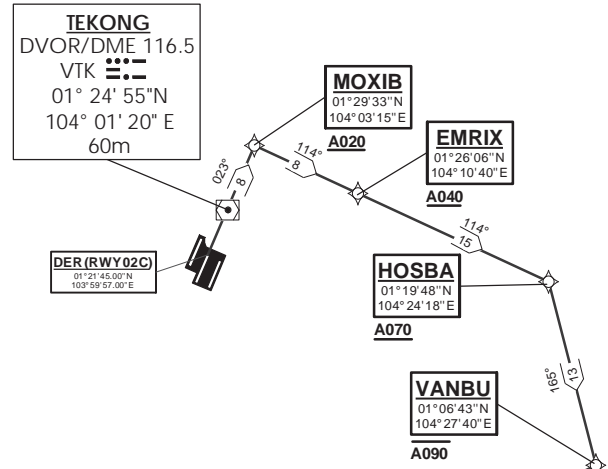
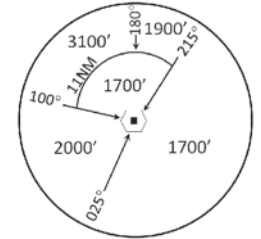

NOT TO SCALE

31 OCT 2024

MIBEL 1A (SID) RNAV GNSS RWY 02C - DESCRIPTIONS**Formal & Abbreviated Descriptions**

Formal Description	Abbreviated Description	Path Terminator	Fly-Over required
To MOXIB on course 023° at or above 2000ft, turn right.	MOXIB [M023; A020+; R] -	CF	N
To EMRIX at or above 4000ft.	EMRIX [A040+] -	TF	N
To HOSBA at or above 7000ft, turn right.	HOSBA [A070+; R] -	TF	N
To VANBU at or below 9000ft, turn right.	VANBU [A090-; R] -	TF	N
To IGOSI.	IGOSI -	TF	N
To ASITI, turn left.	ASITI [L] -	TF	N
To VIBOG, turn right.	VIBOG [R] -	TF	N
To ISGIL.	ISGIL -	TF	N
To BISOV, turn right.	BISOV [R] -	TF	N
To MIBEL.	MIBEL	TF	N

Tabular Descriptions

Path Term	Waypoint Name	Fly-Over	Course °M(°T)	Distance (NM)	Turn Direction	Altitude	Speed Limit	Navigation Spec
CF	MOXIB	-	023(023.4)	8.0	R	A020+	-	RNAV1
TF	EMRIX	-	114(114.4)	8.0	-	A040+	-	RNAV1
TF	HOSBA	-	114(114.4)	15.0	R	A070+	-	RNAV1
TF	VANBU	-	165(165.4)	13.0	R	A090-	-	RNAV1
TF	IGOSI	-	244(244.4)	23.0	-	-	-	RNAV1
TF	ASITI	-	244(244.4)	18.0	L	-	-	RNAV1
TF	VIBOG	-	232(232.4)	10.0	R	-	-	RNAV1
TF	ISGIL	-	269(269.4)	30.0	-	-	-	RNAV1
TF	BISOV	-	269(269.4)	21.0	R	-	-	RNAV1
TF	MIBEL	-	313(313.4)	60.0	-	-	-	RNAV1

Radio Communications Failure Procedure

1	SET TRANSPONDER TO MODE A/C CODE 7600
2	COMMUNICATIONS FAILURE OCCURS IMMEDIATELY AFTER DEPARTURE: PROCEED DIRECT TO NYLON HOLDING AREA (NHA) CLIMBING TO THE LAST ASSIGNED ALTITUDE, THEREAFTER REFER TO SINGAPORE AIP ON RADIO COMMUNICATIONS FAILURE PROCEDURE.

STANDARD DEPARTURE CHART
RNAV (GNSS) -
INSTRUMENT (SID)

TWR 118.6 / 118.25
APP 120.3
124.05
ACC 133.25

TRANSITION ALTITUDE
11 000ft

D-ATIS AP ID-WSSS
128.6

SINGAPORE/Singapore Changi
RWY 20C
MIBEL DEPARTURES
MIBEL 1B

ELEV, ALT IN FEET

BEARINGS, TRACKS AND RADIALS ARE MAGNETIC
VAR 0°23'E (2020)

DISTANCES IN NM

GENERAL INFORMATION

INITIAL CLIMB
3000FT

CAUTION: RWY 02R/20L NOT AVAILABLE FOR CIVIL USE UNTIL FURTHER ADVISED

NOTE: RADAR REQUIRED

NOTE: RNAV-1 NAVIGATION SPECIFICATION GNSS REQUIRED

NOTE: ACFT UNABLE TO FLY THE SID PROFILE SHALL INFORM ATC PRIOR TO DEPARTURE AND EXPECT RADAR VECTORING IF NECESSARY

NOTE: WHEN TAKEN OFF THE SID, AS INSTRUCTED BY ATC, REFER TO ENR 1.5, SECTION 3, PARAGRAPH 3.4.1 - FOR RWY 20C MINIMUM CLIMB GRADIENT

NOTE: REFER TO BACK PAGE FOR
- FORMAL AND TABULAR DESCRIPTIONS
- RADIO COM FAILURE PROCEDURES

PROCEDURE INFORMATION

SID SHALL NOT EXCEED IAS 230KTS UNTIL PASSING 4000FT AMSL AND NOT EXCEED IAS 250KTS UNTIL PASSING 10000FT AMSL.

CRUISING LEVELS WILL BE ISSUED AFTER TAKE-OFF BY SINGAPORE RADAR.

SID SHALL BE ON A MINIMUM CLIMB GRADIENT OF 7% UNTIL REACHING OR PASSING 2500FT, THEREAFTER 3.3%.

GND SPEED - KNOTS	75	100	150	200	250	300
7% V/V (fpm)	532	709	1063	1418	1772	2127
3.3% V/V (fpm)	251	334	501	668	835	1003

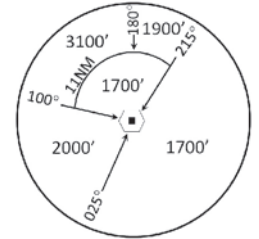

MSA 25 NM from TEKONG DVOR

TEKONG
DVOR/DME 116.5
VTK
01° 24' 55"N
104° 01' 20" E
60m

DER (RWY 20C)
01° 19' 42.00"N
103° 59' 05.00"E

IBIXU
01° 16' 21"N
103° 57' 40"E
A015

IBIVA
01° 13' 51"N
103° 56' 37"E
A025

SAMKO
01° 05' 30"N
103° 52' 55"E
A040

MIBEL
01° 23' 51"N
102° 08' 16"E

BISOV
00° 42' 29"N
102° 52' 14"E

VIBOG
00° 43' 10"N
103° 43' 02"E

ISGIL
00° 42' 46"N
103° 12' 57"E
FL160
FL140

NOT TO SCALE

31 OCT 2024

MIBEL 1B (SID) RNAV GNSS RWY 20C - DESCRIPTIONS**Formal & Abbreviated Descriptions**

Formal Description	Abbreviated Description	Path Terminator	Fly-Over required
To IBIXU on course 203° at or above 1500ft.	IBIXU [M203; A015+] -	CF	N
To IBIVA at or above 2500ft, turn right.	IBIVA [A025+; R] -	TF	N
To SAMKO at or above 4000ft.	SAMKO [A040+] -	TF	N
To VIBOG, turn right.	VIBOG [R] -	TF	N
To ISGIL, between FL140 to FL160.	ISGIL [FL140+; FL160-] -	TF	N
To BISOV, turn right.	BISOV [R] -	TF	N
To MIBEL.	MIBEL	TF	N

Tabular Descriptions

Path Term	Waypoint Name	Fly-Over	Course °M(°T)	Distance (NM)	Turn Direction	Altitude	Speed Limit	Navigation Spec
CF	IBIXU	-	203(203.4)	4.0	-	A015+	-	RNAV1
TF	IBIVA	-	203(203.4)	3.0	R	A025+	-	RNAV1
TF	SAMKO	-	204(204.4)	9.0	-	A040+	-	RNAV1
TF	VIBOG	-	204(204.4)	24.0	R	-	-	RNAV1
TF	ISGIL	-	269(269.4)	30.0	-	FL140+ FL160-	-	RNAV1
TF	BISOV	-	269(269.4)	21.0	R	-	-	RNAV1
TF	MIBEL	-	313(313.4)	60.0	-	-	-	RNAV1

Radio Communications Failure Procedure

1	SET TRANSPONDER TO MODE A/C CODE 7600
2	COMMUNICATIONS FAILURE OCCURS IMMEDIATELY AFTER DEPARTURE: PROCEED DIRECT TO SAMKO HOLDING AREA (SHA) CLIMBING TO THE LAST ASSIGNED ALTITUDE, THEREAFTER REFER TO SINGAPORE AIP ON RADIO COMMUNICATIONS FAILURE PROCEDURE.

STANDARD DEPARTURE CHART
RNAV (GNSS) -
INSTRUMENT (SID)

TWR 118.6 / 118.25
APP 120.3
124.05
ACC 133.25

TRANSITION ALTITUDE
11 000ft

D-ATIS AP ID-WSSS
128.6

SINGAPORE/Singapore Changi
RWY 02R
MIBEL DEPARTURES (RADAR)
MIBEL 1C

ELEV, ALT IN FEET

BEARINGS, TRACKS AND
RADIALS ARE MAGNETIC
VAR 0°23'E (2020)

DISTANCES IN NM

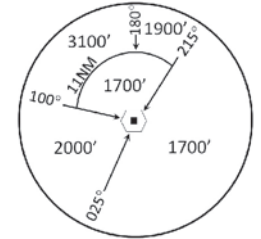

MSA 25 NM
from TEKONG DVOR

GENERAL INFORMATION

INITIAL CLIMB
3000FT

CAUTION: RWY 02R/20L NOT AVAILABLE FOR CIVIL USE UNTIL FURTHER ADVISED

NOTE: RADAR REQUIRED

NOTE: RNAV-1 NAVIGATION SPECIFICATION GNSS REQUIRED

NOTE: ACFT UNABLE TO FLY THE SID PROFILE
SHALL INFORM ATC PRIOR TO DEPARTURE AND
EXPECT RADAR VECTORING IF NECESSARY

NOTE: WHEN TAKEN OFF THE SID, AS INSTRUCTED BY ATC,
REFER TO ENR 1.5, SECTION 3, PARAGRAPH 3.5
- FOR RWY 02R MINIMUM CLIMB GRADIENT

NOTE: REFER TO BACK PAGE FOR
- FORMAL AND TABULAR DESCRIPTIONS
- RADIO COM FAILURE PROCEDURES

PROCEDURE INFORMATION

SID SHALL NOT EXCEED IAS 230KTS UNTIL
PASSING 4000FT AMSL AND NOT EXCEED
IAS 250KTS UNTIL PASSING 10000FT AMSL.

CRUISING LEVELS WILL BE ISSUED AFTER TAKE-OFF
BY SINGAPORE RADAR.

SID SHALL BE ON A MINIMUM CLIMB GRADIENT OF 5%
UNTIL REACHING OR PASSING 2500FT, THEREAFTER 3.3%.

GND SPEED - KNOTS	75	100	150	200	250	300
5% V/V (fpm)	380	506	760	1013	1266	1519
3.3% V/V (fpm)	251	334	501	668	835	1003

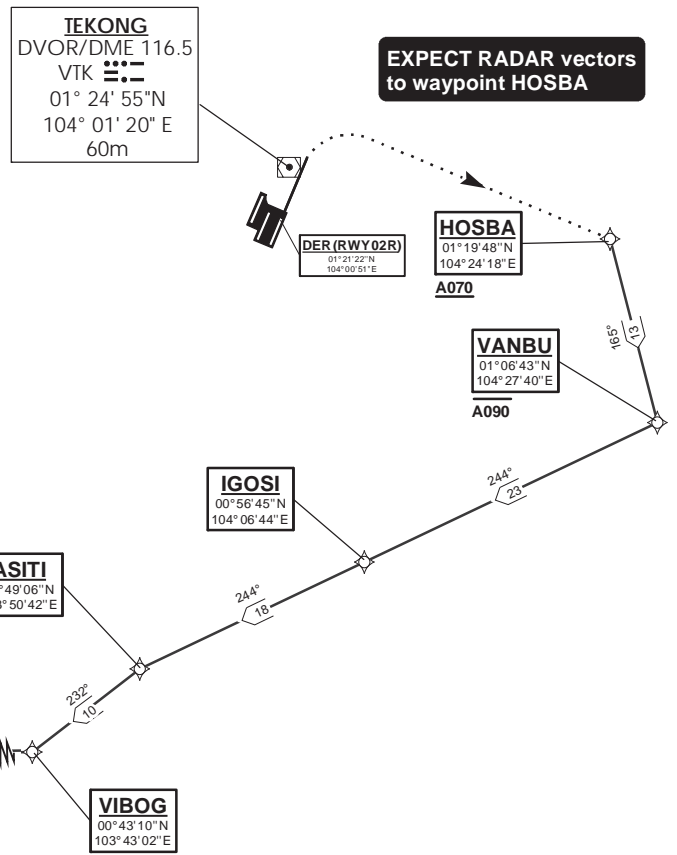

NOT TO SCALE

31 OCT 2024

MIBEL 1C (SID) RNAV GNSS RWY 02R - DESCRIPTIONS**Formal & Abbreviated Descriptions**

Formal Description	Abbreviated Description	Path Terminator	Fly-Over required
Climb heading 023°, Gradient 5% to 2500ft, thence 3.3%. Expect radar vectors to waypoint HOSBA.	-	VA	N
To HOSBA at or above 7000ft.	HOSBA [A070+] -	DF	N
To VANBU at or below 9000ft, turn right.	VANBU [A090-; R] -	TF	N
To IGOSI.	IGOSI -	TF	N
To ASITI, turn left.	ASITI [L] -	TF	N
To VIBOG, turn right.	VIBOG [R] -	TF	N
To ISGIL.	ISGIL -	TF	N
To BISOV, turn right.	BISOV [R] -	TF	N
To MIBEL.	MIBEL	TF	N

Tabular Descriptions

Path Term	Waypoint Name	Fly-Over	Course °M(°T)	Distance (NM)	Turn Direction	Altitude	Speed Limit	Navigation Spec
VA	-	-	023(023.4)	-	-	A030	-	RNAV1
DF	HOSBA	-	-	-	-	A070+	-	RNAV1
TF	VANBU	-	165(165.4)	13.0	R	A090-	-	RNAV1
TF	IGOSI	-	244(244.4)	23.0	-	-	-	RNAV1
TF	ASITI	-	244(244.4)	18.0	L	-	-	RNAV1
TF	VIBOG	-	232(232.3)	10.0	R	-	-	RNAV1
TF	ISGIL	-	269(269.4)	30.0	-	-	-	RNAV1
TF	BISOV	-	269(269.4)	21.0	R	-	-	RNAV1
TF	MIBEL	-	313(313.4)	60.0	-	-	-	RNAV1

Radio Communications Failure Procedure

1	SET TRANSPONDER TO MODE A/C CODE 7600
2	COMMUNICATIONS FAILURE OCCURS IMMEDIATELY AFTER DEPARTURE: PROCEED DIRECT TO NYLON HOLDING AREA (NHA) CLIMBING TO THE LAST ASSIGNED ALTITUDE, THEREAFTER REFER TO SINGAPORE AIP ON RADIO COMMUNICATIONS FAILURE PROCEDURE.

STANDARD DEPARTURE CHART
RNAV (GNSS) -
INSTRUMENT (SID)

TWR 118.6 / 118.25
APP 120.3
124.05
ACC 133.25

TRANSITION ALTITUDE
11 000ft

D-ATIS AP ID-WSSS
128.6

SINGAPORE/Singapore Changi
RWY 20L
MIBEL DEPARTURES
MIBEL 1D

ELEV, ALT IN FEET

BEARINGS, TRACKS AND
RADIALS ARE MAGNETIC
VAR 0°23'E (2020)

DISTANCES IN NM

GENERAL INFORMATION

INITIAL CLIMB
3000FT

CAUTION: RWY 02R/20L NOT AVAILABLE FOR CIVIL USE UNTIL FURTHER ADVISED

NOTE: RADAR REQUIRED

NOTE: RNAV-1 NAVIGATION SPECIFICATION GNSS REQUIRED

NOTE: ACFT UNABLE TO FLY THE SID PROFILE SHALL INFORM ATC PRIOR TO DEPARTURE AND EXPECT RADAR VECTORING IF NECESSARY

NOTE: WHEN TAKEN OFF THE SID, AS INSTRUCTED BY ATC, REFER TO ENR 1.5, SECTION 3, PARAGRAPH 3.4.3 - FOR RWY 20L MINIMUM CLIMB GRADIENT

NOTE: REFER TO BACK PAGE FOR
- FORMAL AND TABULAR DESCRIPTIONS
- RADIO COM FAILURE PROCEDURES

PROCEDURE INFORMATION

SID SHALL NOT EXCEED IAS 230KTS UNTIL PASSING 4000FT AMSL AND NOT EXCEED IAS 250KTS UNTIL PASSING 10000FT AMSL.

CRUISING LEVELS WILL BE ISSUED AFTER TAKE-OFF BY SINGAPORE RADAR.

SID SHALL BE ON A MINIMUM CLIMB GRADIENT OF 9% UNTIL REACHING OR PASSING 2500FT, THEREAFTER 3.3%.

GND SPEED - KNOTS	75	100	150	200	250	300
9% V/V (fpm)	684	911	1367	1823	2279	2734
3.3% V/V (fpm)	251	334	501	668	835	1003

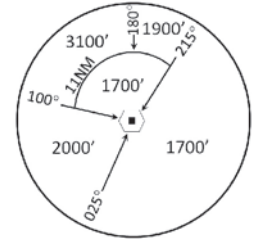

TEKONG
DVOR/DME 116.5
VTK
01° 24' 55"N
104° 01' 20" E
60m

DER (RWY 20L)
01° 19' 19"N
103° 59' 59"E

UKIBO
01° 17' 58"N
103° 59' 24"E

VIGUD
01° 13' 28"N
103° 57' 30"E
A025

SAMKO
01° 05' 30"N
103° 52' 55"E
A040

MIBEL
01° 23' 51"N
102° 08' 16"E

BISOV
00° 42' 29"N
102° 52' 14"E

VIBOG
00° 43' 10"N
103° 43' 02"E

ISGIL
00° 42' 46"N
103° 12' 57"E
FL160
FL140

NOT TO SCALE

MIBEL 1D (SID) RNAV GNSS RWY 20L - DESCRIPTIONS

Formal & Abbreviated Descriptions

Formal Description	Abbreviated Description	Path Terminator	Fly-Over required
To UKIBO on course 203°.	UKIBO [M203] -	CF	N
To VIGUD at or above 2500ft, turn right.	VIGUD [A025+; R] -	TF	N
To SAMKO at or above 4000ft, turn left.	SAMKO [A040+; L] -	TF	N
To VIBOG, turn right.	VIBOG [R] -	TF	N
To ISGIL, between FL140 to FL160.	ISGIL [FL140+; FL160-] -	TF	N
To BISOV, turn right.	BISOV [R] -	TF	N
To MIBEL.	MIBEL	TF	N

Tabular Descriptions

Path Term	Waypoint Name	Fly-Over	Course °M(°T)	Distance (NM)	Turn Direction	Altitude	Speed Limit	Navigation Spec
CF	UKIBO	Y	203(203.4)	1.5	-	-	-	RNAV1
TF	VIGUD	-	203(203.4)	5.0	R	A025+	-	RNAV1
TF	SAMKO	-	210(210.4)	9.0	L	A040+	-	RNAV1
TF	VIBOG	-	204(204.4)	24.0	R	-	-	RNAV1
TF	ISGIL	-	269(269.4)	30.0	-	FL140+ FL160-	-	RNAV1
TF	BISOV	-	269(269.4)	21.0	R	-	-	RNAV1
TF	MIBEL	-	313(313.4)	60.0	-	-	-	RNAV1

Radio Communications Failure Procedure

1	SET TRANSPONDER TO MODE A/C CODE 7600
2	COMMUNICATIONS FAILURE OCCURS IMMEDIATELY AFTER DEPARTURE: PROCEED DIRECT TO SAMKO HOLDING AREA (SHA) CLIMBING TO THE LAST ASSIGNED ALTITUDE, THEREAFTER REFER TO SINGAPORE AIP ON RADIO COMMUNICATIONS FAILURE PROCEDURE.

STANDARD DEPARTURE CHART
RNAV (GNSS) -
INSTRUMENT (SID)

TWR 118.6 / 118.25
APP 120.3
124.05
ACC 133.25

TRANSITION ALTITUDE
11 000ft

D-ATIS AP ID-WSSS
128.6

SINGAPORE/Singapore Changi
RWY 02L
MIBEL DEPARTURES
MIBEL 1E

ELEV, ALT IN FEET

BEARINGS, TRACKS AND
RADIALS ARE MAGNETIC
VAR 0°23'E (2020)

DISTANCES IN NM

GENERAL INFORMATION

INITIAL CLIMB
3000FT

CAUTION: RWY 02R/20L NOT AVAILABLE FOR CIVIL USE UNTIL FURTHER ADVISED

NOTE: RADAR REQUIRED

NOTE: RNAV-1 NAVIGATION SPECIFICATION GNSS REQUIRED

NOTE: ACFT UNABLE TO FLY THE SID PROFILE
SHALL INFORM ATC PRIOR TO DEPARTURE AND
EXPECT RADAR VECTORED IF NECESSARY

NOTE: WHEN TAKEN OFF THE SID, AS INSTRUCTED BY ATC,
REFER TO ENR 1.5, SECTION 3, PARAGRAPH 3.2 [A]
- FOR RWY 02L MINIMUM CLIMB GRADIENT

NOTE: REFER TO BACK PAGE FOR
- FORMAL AND TABULAR DESCRIPTIONS
- RADIO COM FAILURE PROCEDURES

PROCEDURE INFORMATION

SID SHALL NOT EXCEED IAS 230KTS UNTIL
PASSING 4000FT AMSL AND NOT EXCEED
IAS 250KTS UNTIL PASSING 10000FT AMSL.

CRUISING LEVELS WILL BE ISSUED AFTER TAKE-OFF
BY SINGAPORE RADAR.

SID SHALL BE ON A MINIMUM CLIMB GRADIENT OF 5%
UNTIL REACHING OR PASSING 2500FT, THEREAFTER 3.3%.

GND SPEED - KNOTS	75	100	150	200	250	300
5% V/V (fpm)	380	506	760	1013	1266	1519
3.3% V/V (fpm)	251	334	501	668	835	1003

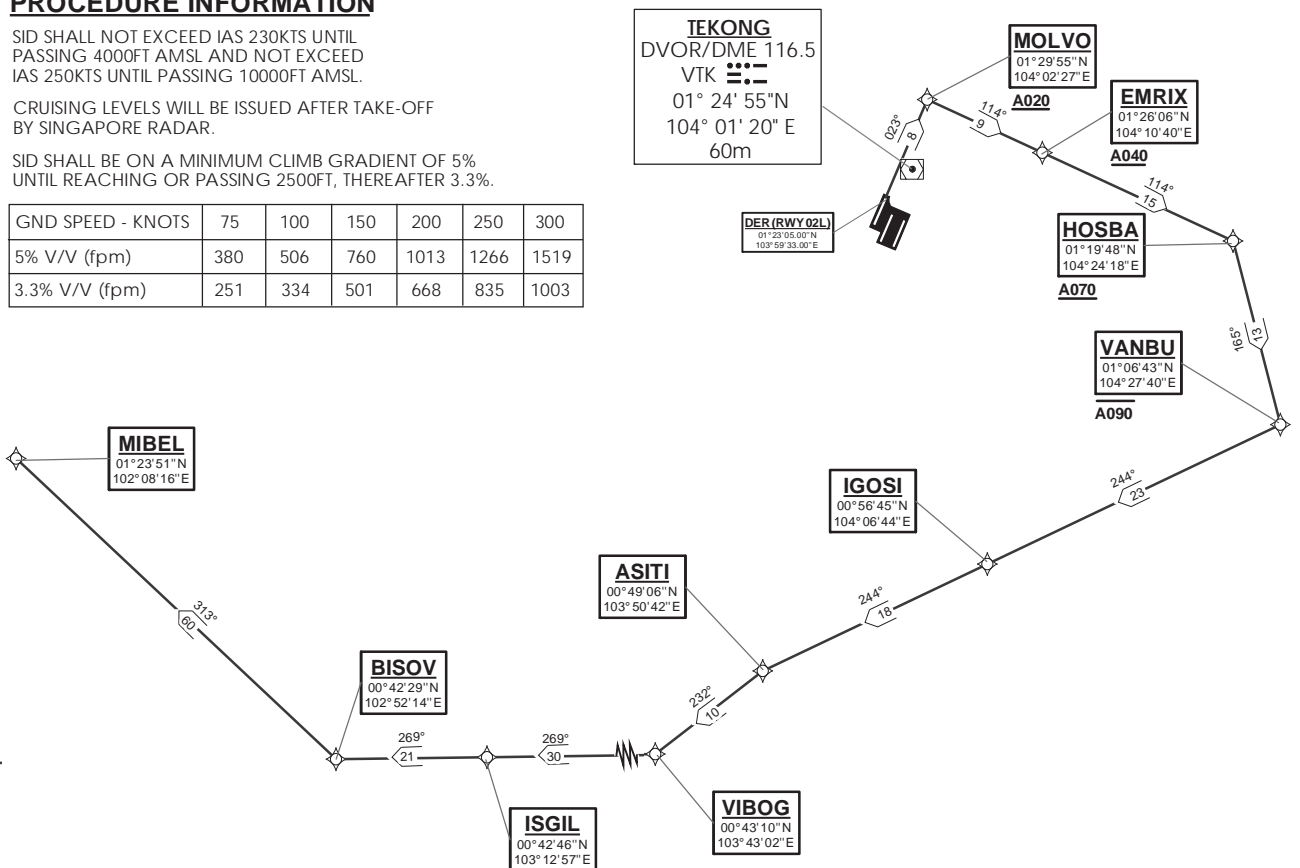
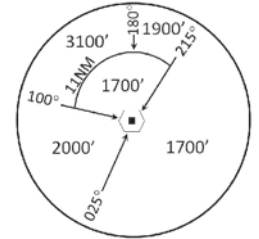

NOT TO SCALE

31 OCT 2024

MIBEL 1E (SID) RNAV GNSS RWY 02L - DESCRIPTIONS**Formal & Abbreviated Descriptions**

Formal Description	Abbreviated Description	Path Terminator	Fly-Over required
To MOLVO on course 023° at or above 2000ft, turn right.	MOLVO [M023; A020+; R] -	CF	N
To EMRIX at or above 4000ft.	EMRIX [A040+] -	TF	N
To HOSBA at or above 7000ft, turn right.	HOSBA [A070+; R] -	TF	N
To VANBU at or below 9000ft, turn right.	VANBU [A090-; R] -	TF	N
To IGOSI.	IGOSI -	TF	N
To ASITI, turn left.	ASITI [L] -	TF	N
To VIBOG, turn right.	VIBOG [R] -	TF	N
To ISGIL.	ISGIL -	TF	N
To BISOV, turn right.	BISOV [R] -	TF	N
To MIBEL.	MIBEL	TF	N

Tabular Descriptions

Path Term	Waypoint Name	Fly-Over	Course °M(°T)	Distance (NM)	Turn Direction	Altitude	Speed Limit	Navigation Spec
CF	MOLVO	-	023(023.4)	8.0	R	A020+	-	RNAV1
TF	EMRIX	-	114(114.4)	9.0	-	A040+	-	RNAV1
TF	HOSBA	-	114(114.4)	15.0	R	A070+	-	RNAV1
TF	VANBU	-	165(165.4)	13.0	R	A090-	-	RNAV1
TF	IGOSI	-	244(244.4)	23.0	-	-	-	RNAV1
TF	ASITI	-	244(244.4)	18.0	L	-	-	RNAV1
TF	VIBOG	-	232(232.3)	10.0	R	-	-	RNAV1
TF	ISGIL	-	269(269.4)	30.0	-	-	-	RNAV1
TF	BISOV	-	269(269.4)	21.0	R	-	-	RNAV1
TF	MIBEL	-	313(313.4)	60.0	-	-	-	RNAV1

Radio Communications Failure Procedure

1	SET TRANSPONDER TO MODE A/C CODE 7600
2	COMMUNICATIONS FAILURE OCCURS IMMEDIATELY AFTER DEPARTURE: PROCEED DIRECT TO NYLON HOLDING AREA (NHA) CLIMBING TO THE LAST ASSIGNED ALTITUDE, THEREAFTER REFER TO SINGAPORE AIP ON RADIO COMMUNICATIONS FAILURE PROCEDURE.

STANDARD DEPARTURE CHART
RNAV (GNSS) -
INSTRUMENT (SID)

TWR 118.6 / 118.25
APP 120.3
124.05
ACC 133.25

TRANSITION ALTITUDE
11 000ft

D-ATIS AP ID-WSSS
128.6

SINGAPORE/Singapore Changi
RWY 20R
MIBEL DEPARTURES
MIBEL 1F

ELEV, ALT IN FEET

BEARINGS, TRACKS AND RADIALS ARE MAGNETIC
VAR 0°23'E (2020)

DISTANCES IN NM

GENERAL INFORMATION

INITIAL CLIMB
3000FT

CAUTION: RWY 02R/20L NOT AVAILABLE FOR CIVIL USE UNTIL FURTHER ADVISED

NOTE: RADAR REQUIRED

NOTE: RNAV-1 NAVIGATION SPECIFICATION GNSS REQUIRED

NOTE: ACFT UNABLE TO FLY THE SID PROFILE
SHALL INFORM ATC PRIOR TO DEPARTURE AND
EXPECT RADAR VECTORING IF NECESSARY

NOTE: WHEN TAKEN OFF THE SID, AS INSTRUCTED BY ATC,
REFER TO ENR 1.5, SECTION 3, PARAGRAPH 3.4.2
- FOR RWY 20R MINIMUM CLIMB GRADIENT

NOTE: REFER TO BACK PAGE FOR
- FORMAL AND TABULAR DESCRIPTIONS
- RADIO COM FAILURE PROCEDURES

PROCEDURE INFORMATION

SID SHALL NOT EXCEED IAS 230KTS UNTIL
PASSING 4000FT AMSL AND NOT EXCEED
IAS 250KTS UNTIL PASSING 10000FT AMSL.

CRUISING LEVELS WILL BE ISSUED AFTER TAKE-OFF
BY SINGAPORE RADAR.

SID SHALL BE ON A MINIMUM CLIMB GRADIENT OF 6%
UNTIL REACHING OR PASSING 2500FT, THEREAFTER 3.3%.

GND SPEED - KNOTS	75	100	150	200	250	300
6% V/V (fpm)	456	608	911	1215	1518	1821
3.3% V/V (fpm)	251	334	501	668	835	1003

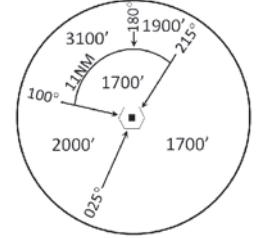

TEKONG
DVOR/DME 116.5
VTK
01° 24' 55"N
104° 01' 20" E
60m

DER (RWY 20R)
01° 20' 47.00"N
103° 58' 35.00"E

LEDOX
01° 16' 42"N
103° 56' 51"E
A015

LETGO
01° 14' 11"N
103° 55' 48"E
A025

SAMKO
01° 05' 30"N
103° 52' 55"E
A040

MIBEL
01° 23' 51"N
102° 08' 16"E

BISOV
00° 42' 29"N
102° 52' 14"E

ISGIL
00° 42' 46"N
103° 12' 57"E
FL160
FL140

VIBOG
00° 43' 10"N
103° 43' 02"E

NOT TO SCALE

31 OCT 2024

MIBEL 1F (SID) RNAV GNSS RWY 20R - DESCRIPTIONS**Formal & Abbreviated Descriptions**

Formal Description	Abbreviated Description	Path Terminator	Fly-Over required
To LEDOX on course 203° at or above 1500ft.	LEDOX [M203; A015+] -	CF	N
To LETGO at or above 2500ft, turn left.	LETGO [A025+; L] -	TF	N
To SAMKO at or above 4000ft, turn right.	SAMKO [A040+; R] -	TF	N
To VIBOG, turn right.	VIBOG [R] -	TF	N
To ISGIL, between FL140 to FL160.	ISGIL [FL140+; FL160-] -	TF	N
To BISOV, turn right.	BISOV [R] -	TF	N
To MIBEL.	MIBEL	TF	N

Tabular Descriptions

Path Term	Waypoint Name	Fly-Over	Course °M(°T)	Distance (NM)	Turn Direction	Altitude	Speed Limit	Navigation Spec
CF	LEDOX	-	203(203.4)	5.0	-	A015+	-	RNAV1
TF	LETGO	-	203(203.4)	3.0	L	A025+	-	RNAV1
TF	SAMKO	-	198(198.4)	9.0	R	A040+	-	RNAV1
TF	VIBOG	-	204(204.4)	24.0	R	-	-	RNAV1
TF	ISGIL	-	269(269.4)	30.0	-	FL140+ FL160-	-	RNAV1
TF	BISOV	-	269(269.4)	21.0	R	-	-	RNAV1
TF	MIBEL	-	313(313.4)	60.0	-	-	-	RNAV1

Radio Communications Failure Procedure

1	SET TRANSPONDER TO MODE A/C CODE 7600
2	COMMUNICATIONS FAILURE OCCURS IMMEDIATELY AFTER DEPARTURE: PROCEED DIRECT TO SAMKO HOLDING AREA (SHA) CLIMBING TO THE LAST ASSIGNED ALTITUDE, THEREAFTER REFER TO SINGAPORE AIP ON RADIO COMMUNICATIONS FAILURE PROCEDURE.

STANDARD DEPARTURE CHART
RNAV (GNSS) -
INSTRUMENT (SID)

TWR 118.6 / 118.25
APP 120.3
124.05
ACC 133.25

TRANSITION ALTITUDE
11 000ft

D-ATIS AP ID-WSSS
128.6

SINGAPORE/Singapore Changi
RWY 02C
TAROS DEPARTURES
TAROS 1A

ELEV, ALT IN FEET

BEARINGS, TRACKS AND
RADIALS ARE MAGNETIC
VAR 0°23'E (2020)

DISTANCES IN NM

GENERAL INFORMATION

INITIAL CLIMB
3000FT

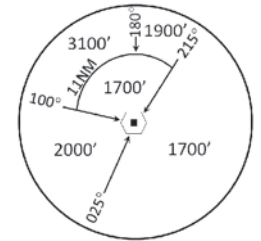

CAUTION: RWY 02R/20L NOT AVAILABLE FOR CIVIL USE UNTIL FURTHER ADVISED

NOTE: RADAR REQUIRED

NOTE: RNAV-1 NAVIGATION SPECIFICATION
GNSS REQUIRED

NOTE: CLOSE-IN OBSTACLES (AIRCRAFT UP TO 80FT)
EXIST ON TAXIWAYS WEST OF RUNWAY 02C

NOTE: ACFT UNABLE TO FLY THE SID
PROFILE SHALL INFORM ATC
PRIOR TO DEPARTURE AND TO
EXPECT RADAR VECTORING,
IF NECESSARY

NOTE: WHEN TAKEN OFF THE SID,
AS INSTRUCTED BY ATC,
REFER TO ENR 1.5, SECTION 3,
PARAGRAPH 3.3 [A] - FOR RWY 02C MINIMUM CLIMB GRADIENT

NOTE: REFER TO BACK PAGE FOR
- FORMAL AND TABULAR DESCRIPTIONS
- RADIO COM FAILURE PROCEDURES

PROCEDURE INFORMATION

SID SHALL NOT EXCEED IAS 230KTS UNTIL PASSING 4000FT AMSL AND
NOT EXCEED IAS 250KTS UNTIL PASSING 10000FT AMSL.

CRUISING LEVELS WILL BE ISSUED AFTER TAKE-OFF
BY SINGAPORE RADAR.

SID SHALL BE ON A MINIMUM CLIMB GRADIENT OF 5%
UNTIL REACHING OR PASSING 2500FT, THEREAFTER 3.3%.

GND SPEED - KNOTS	75	100	150	200	250	300
5% V/V (fpm)	380	506	760	1013	1266	1519
3.3% V/V (fpm)	251	334	501	668	835	1003

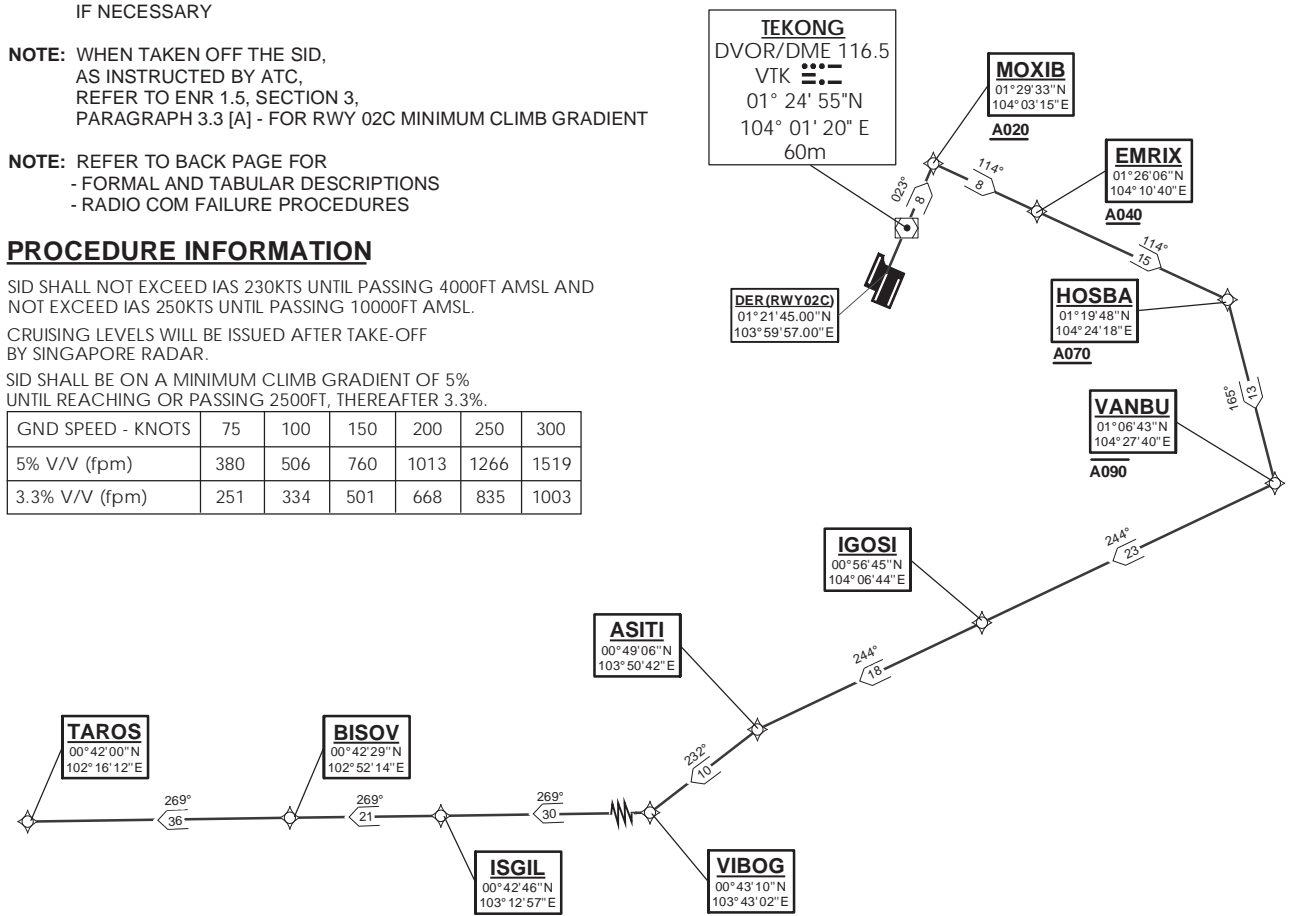

NOT TO SCALE

31 OCT 2024

TAROS 1A (SID) RNAV GNSS RWY 02C - DESCRIPTIONS**Formal & Abbreviated Descriptions**

Formal Description	Abbreviated Description	Path Terminator	Fly-Over required
To MOXIB on course 023° at or above 2000ft, turn right.	MOXIB [M023; A020+; R] -	CF	N
To EMRIX at or above 4000ft.	EMRIX [A040+] -	TF	N
To HOSBA at or above 7000ft, turn right.	HOSBA [A070+; R] -	TF	N
To VANBU at or below 9000ft, turn right.	VANBU [A090-; R] -	TF	N
To IGOSI.	IGOSI -	TF	N
To ASITI, turn left.	ASITI [L] -	TF	N
To VIBOG, turn right.	VIBOG [R] -	TF	N
To ISGIL.	ISGIL -	TF	N
To BISOV.	BISOV -	TF	N
To TAROS.	TAROS	TF	N

Tabular Descriptions

Path Term	Waypoint Name	Fly-Over	Course °M(°T)	Distance (NM)	Turn Direction	Altitude	Speed Limit	Navigation Spec
CF	MOXIB	-	023(023.4)	8.0	R	A020+	-	RNAV1
TF	EMRIX	-	114(114.4)	8.0	-	A040+	-	RNAV1
TF	HOSBA	-	114(114.4)	15.0	R	A070+	-	RNAV1
TF	VANBU	-	165(165.4)	13.0	R	A090-	-	RNAV1
TF	IGOSI	-	244(244.4)	23.0	-	-	-	RNAV1
TF	ASITI	-	244(244.4)	18.0	L	-	-	RNAV1
TF	VIBOG	-	232(232.4)	10.0	R	-	-	RNAV1
TF	ISGIL	-	269(269.4)	30.0	-	-	-	RNAV1
TF	BISOV	-	269(269.4)	21.0	-	-	-	RNAV1
TF	TAROS	-	269(269.4)	36.0	-	-	-	RNAV1

Radio Communications Failure Procedure

1	SET TRANSPONDER TO MODE A/C CODE 7600
2	COMMUNICATIONS FAILURE OCCURS IMMEDIATELY AFTER DEPARTURE: PROCEED DIRECT TO NYLON HOLDING AREA (NHA) CLIMBING TO THE LAST ASSIGNED ALTITUDE, THEREAFTER REFER TO SINGAPORE AIP ON RADIO COMMUNICATIONS FAILURE PROCEDURE.

STANDARD DEPARTURE CHART
RNAV (GNSS) -
INSTRUMENT (SID)

TWR 118.6 / 118.25
APP 120.3
124.05
ACC 133.25

TRANSITION ALTITUDE
11 000ft

D-ATIS AP ID-WSSS
128.6

SINGAPORE/Singapore Changi
RWY 20C
TAROS DEPARTURES
TAROS 1B

ELEV, ALT IN FEET

BEARINGS, TRACKS AND
RADIALS ARE MAGNETIC
VAR 0°23'E (2020)

DISTANCES IN NM

GENERAL INFORMATION

INITIAL CLIMB
3000FT

CAUTION: RWY 02R/20L NOT AVAILABLE FOR CIVIL USE UNTIL FURTHER ADVISED

NOTE: RADAR REQUIRED

NOTE: RNAV-1 NAVIGATION SPECIFICATION GNSS REQUIRED

NOTE: ACFT UNABLE TO FLY THE SID PROFILE
SHALL INFORM ATC PRIOR TO DEPARTURE AND
EXPECT RADAR VECTORED IF NECESSARY

NOTE: WHEN TAKEN OFF THE SID, AS INSTRUCTED BY ATC,
REFER TO ENR 1.5, SECTION 3, PARAGRAPH 3.4.1
- FOR RWY 20C MINIMUM CLIMB GRADIENT

NOTE: REFER TO BACK PAGE FOR
- FORMAL AND TABULAR DESCRIPTIONS
- RADIO COM FAILURE PROCEDURES

PROCEDURE INFORMATION

SID SHALL NOT EXCEED IAS 230KTS UNTIL
PASSING 4000FT AMSL AND NOT EXCEED
IAS 250KTS UNTIL PASSING 10000FT AMSL.

CRUISING LEVELS WILL BE ISSUED AFTER TAKE-OFF
BY SINGAPORE RADAR.

SID SHALL BE ON A MINIMUM CLIMB GRADIENT OF 7%
UNTIL REACHING OR PASSING 2500FT, THEREAFTER 3.3%.

GND SPEED - KNOTS	75	100	150	200	250	300
7% V/V (fpm)	532	709	1063	1418	1772	2127
3.3% V/V (fpm)	251	334	501	668	835	1003

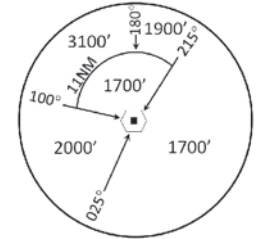

TEKONG
DVOR/DME 116.5
VTK
01° 24' 55"N
104° 01' 20" E
60m

DER (RWY 20C)
01° 19' 42.00"N
103° 59' 05.00"E

IBIXU
01° 16' 21"N
103° 57' 40"E
A015

IBIVA
01° 13' 51"N
103° 56' 37"E
A025

SAMKO
01° 05' 30"N
103° 52' 55"E
A040

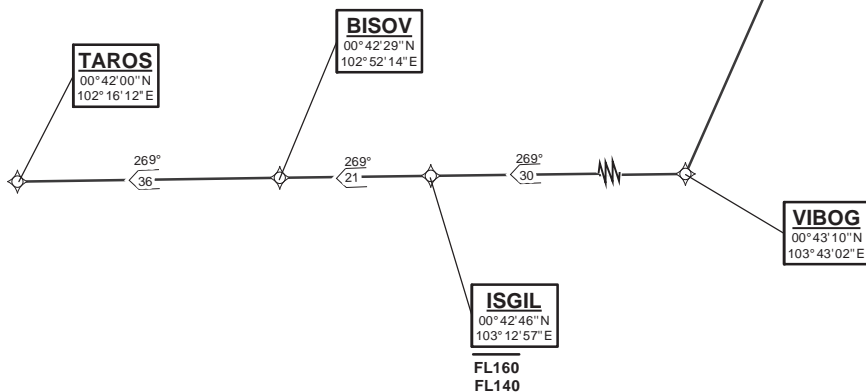

NOT TO SCALE

TAROS 1B (SID) RNAV GNSS RWY 20C - DESCRIPTIONS**Formal & Abbreviated Descriptions**

Formal Description	Abbreviated Description	Path Terminator	Fly-Over required
To IBIXU on course 203° at or above 1500ft.	IBIXU [M203; A015+] -	CF	N
To IBIVA at or above 2500ft, turn right.	IBIVA [A025+; R] -	TF	N
To SAMKO at or above 4000ft.	SAMKO [A040+] -	TF	N
To VIBOG, turn right.	VIBOG [R] -	TF	N
To ISGIL, between FL140 to FL160.	ISGIL [FL140+; FL160-] -	TF	N
To BISOV.	BISOV -	TF	N
To TAROS.	TAROS	TF	N

Tabular Descriptions

Path Term	Waypoint Name	Fly-Over	Course °M(°T)	Distance (NM)	Turn Direction	Altitude	Speed Limit	Navigation Spec
CF	IBIXU	-	203(203.4)	4.0	-	A015+	-	RNAV1
TF	IBIVA	-	203(203.4)	3.0	R	A025+	-	RNAV1
TF	SAMKO	-	204(204.4)	9.0	-	A040+	-	RNAV1
TF	VIBOG	-	204(204.4)	24.0	R	-	-	RNAV1
TF	ISGIL	-	269(269.4)	30.0	-	FL140+ FL160-	-	RNAV1
TF	BISOV	-	269(269.4)	21.0	-	-	-	RNAV1
TF	TAROS	-	269(269.4)	36.0	-	-	-	RNAV1

Radio Communications Failure Procedure

1	SET TRANSPONDER TO MODE A/C CODE 7600
2	COMMUNICATIONS FAILURE OCCURS IMMEDIATELY AFTER DEPARTURE: PROCEED DIRECT TO SAMKO HOLDING AREA (SHA) CLIMBING TO THE LAST ASSIGNED ALTITUDE, THEREAFTER REFER TO SINGAPORE AIP ON RADIO COMMUNICATIONS FAILURE PROCEDURE.

STANDARD DEPARTURE CHART
RNAV (GNSS) -
INSTRUMENT (SID)

TWR 118.6 / 118.25
APP 120.3
124.05
ACC 133.25

TRANSITION ALTITUDE
11 000ft

D-ATIS AP ID-WSSS
128.6

SINGAPORE/Singapore Changi
RWY 02R
TAROS DEPARTURES (RADAR)
TAROS 1C

ELEV, ALT IN FEET

BEARINGS, TRACKS AND
RADIALS ARE MAGNETIC
VAR 0°23'E (2020)

DISTANCES IN NM

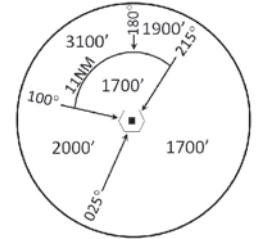

MSA 25 NM
from TEKONG DVOR

GENERAL INFORMATION

INITIAL CLIMB
3000FT

CAUTION: RWY 02R/20L NOT AVAILABLE FOR CIVIL USE UNTIL FURTHER ADVISED

NOTE: RADAR REQUIRED

NOTE: RNAV-1 NAVIGATION SPECIFICATION GNSS REQUIRED

NOTE: ACFT UNABLE TO FLY THE SID PROFILE SHALL INFORM ATC PRIOR TO DEPARTURE AND EXPECT RADAR VECTORING IF NECESSARY

NOTE: WHEN TAKEN OFF THE SID, AS INSTRUCTED BY ATC, REFER TO ENR 1.5, SECTION 3, PARAGRAPH 3.5 - FOR RWY 02R MINIMUM CLIMB GRADIENT

NOTE: REFER TO BACK PAGE FOR
- FORMAL AND TABULAR DESCRIPTIONS
- RADIO COM FAILURE PROCEDURES

PROCEDURE INFORMATION

SID SHALL NOT EXCEED IAS 230KTS UNTIL PASSING 4000FT AMSL AND NOT EXCEED IAS 250KTS UNTIL PASSING 10000FT AMSL.

CRUISING LEVELS WILL BE ISSUED AFTER TAKE-OFF BY SINGAPORE RADAR.

SID SHALL BE ON A MINIMUM CLIMB GRADIENT OF 5% UNTIL REACHING OR PASSING 2500FT, THEREAFTER 3.3%.

GND SPEED - KNOTS	75	100	150	200	250	300
5% V/V (fpm)	380	506	760	1013	1266	1519
3.3% V/V (fpm)	251	334	501	668	835	1003

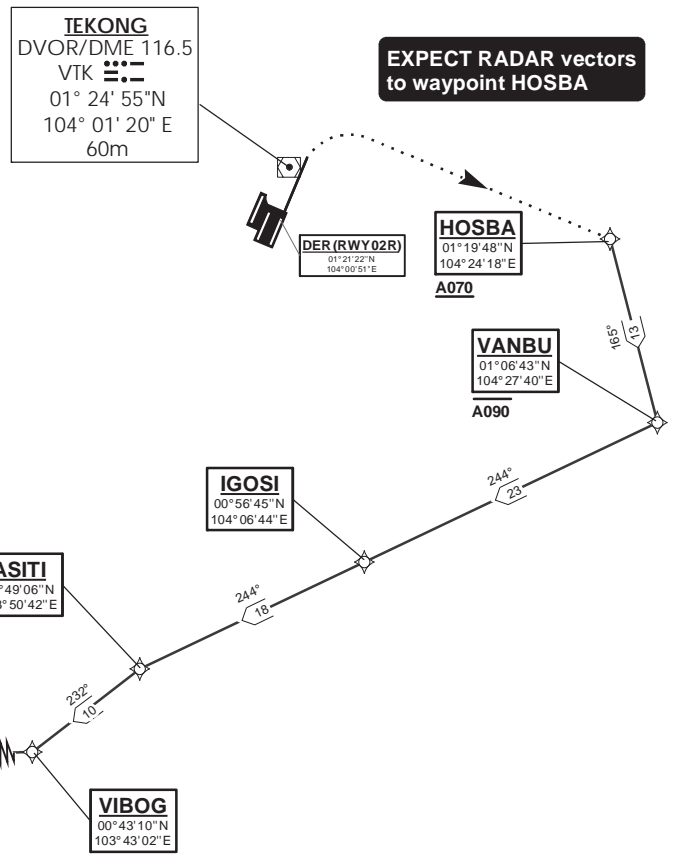

EXPECT RADAR vectors to waypoint HOSBA

NOT TO SCALE

TAROS 1C (SID) RNAV GNSS RWY 02R - DESCRIPTIONS**Formal & Abbreviated Descriptions**

Formal Description	Abbreviated Description	Path Terminator	Fly-Over required
Climb heading 023°, Gradient 5% to 2500ft, thence 3.3%. Expect radar vectors to waypoint HOSBA.	-	VA	N
To HOSBA at or above 7000ft.	HOSBA [A070+] -	DF	N
To VANBU at or below 9000ft, turn right.	VANBU [A090-; R] -	TF	N
To IGOSI.	IGOSI -	TF	N
To ASITI, turn left.	ASITI [L] -	TF	N
To VIBOG, turn right.	VIBOG [R] -	TF	N
To ISGIL.	ISGIL -	TF	N
To BISOV.	BISOV -	TF	N
To TAROS.	TAROS	TF	N

Tabular Descriptions

Path Term	Waypoint Name	Fly-Over	Course °M(°T)	Distance (NM)	Turn Direction	Altitude	Speed Limit	Navigation Spec
VA	-	-	023(023.4)	-	-	A030	-	RNAV1
DF	HOSBA	-	-	-	-	A070+	-	RNAV1
TF	VANBU	-	165(165.4)	13.0	R	A090-	-	RNAV1
TF	IGOSI	-	244(244.4)	23.0	-	-	-	RNAV1
TF	ASITI	-	244(244.4)	18.0	L	-	-	RNAV1
TF	VIBOG	-	232(232.3)	10.0	R	-	-	RNAV1
TF	ISGIL	-	269(269.4)	30.0	-	-	-	RNAV1
TF	BISOV	-	269(269.4)	21.0	-	-	-	RNAV1
TF	TAROS	-	269(269.4)	36.0	-	-	-	RNAV1

Radio Communications Failure Procedure

1	SET TRANSPONDER TO MODE A/C CODE 7600
2	COMMUNICATIONS FAILURE OCCURS IMMEDIATELY AFTER DEPARTURE: PROCEED DIRECT TO NYLON HOLDING AREA (NHA) CLIMBING TO THE LAST ASSIGNED ALTITUDE, THEREAFTER REFER TO SINGAPORE AIP ON RADIO COMMUNICATIONS FAILURE PROCEDURE.

STANDARD DEPARTURE CHART
RNAV (GNSS) -
INSTRUMENT (SID)

TWR 118.6 / 118.25
APP 120.3
124.05
ACC 133.25

TRANSITION ALTITUDE
11 000ft

D-ATIS AP ID-WSSS
128.6

SINGAPORE/Singapore Changi
RWY 20L
TAROS DEPARTURES
TAROS 1D

ELEV, ALT IN FEET

BEARINGS, TRACKS AND
RADIALS ARE MAGNETIC
VAR 0°23'E (2020)

DISTANCES IN NM

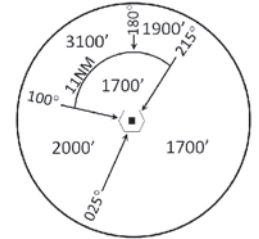

GENERAL INFORMATION

INITIAL CLIMB
3000FT

CAUTION: RWY 02R/20L NOT AVAILABLE FOR CIVIL USE UNTIL FURTHER ADVISED

NOTE: RADAR REQUIRED

NOTE: RNAV-1 NAVIGATION SPECIFICATION GNSS REQUIRED

NOTE: ACFT UNABLE TO FLY THE SID PROFILE
SHALL INFORM ATC PRIOR TO DEPARTURE AND
EXPECT RADAR VECTORING IF NECESSARY

NOTE: WHEN TAKEN OFF THE SID, AS INSTRUCTED BY ATC,
REFER TO ENR 1.5, SECTION 3, PARAGRAPH 3.4.3
- FOR RWY 20L MINIMUM CLIMB GRADIENT

NOTE: REFER TO BACK PAGE FOR
- FORMAL AND TABULAR DESCRIPTIONS
- RADIO COM FAILURE PROCEDURES

PROCEDURE INFORMATION

SID SHALL NOT EXCEED IAS 230KTS UNTIL
PASSING 4000FT AMSL AND NOT EXCEED
IAS 250KTS UNTIL PASSING 10000FT AMSL.

CRUISING LEVELS WILL BE ISSUED AFTER TAKE-OFF
BY SINGAPORE RADAR.

SID SHALL BE ON A MINIMUM CLIMB GRADIENT OF 9%
UNTIL REACHING OR PASSING 2500FT, THEREAFTER 3.3%.

GND SPEED - KNOTS	75	100	150	200	250	300
9% V/V (fpm)	684	911	1367	1823	2279	2734
3.3% V/V (fpm)	251	334	501	668	835	1003

TEKONG
DVOR/DME 116.5
VTK
01° 24' 55"N
104° 01' 20" E
60m

DER (RWY 20L)
01° 19' 19"N
103° 59' 59"E

UKIBO
01° 17' 58"N
103° 59' 24"E

VIGUD
01° 13' 28"N
103° 57' 30"E
A025

SAMKO
01° 05' 30"N
103° 52' 55"E
A040

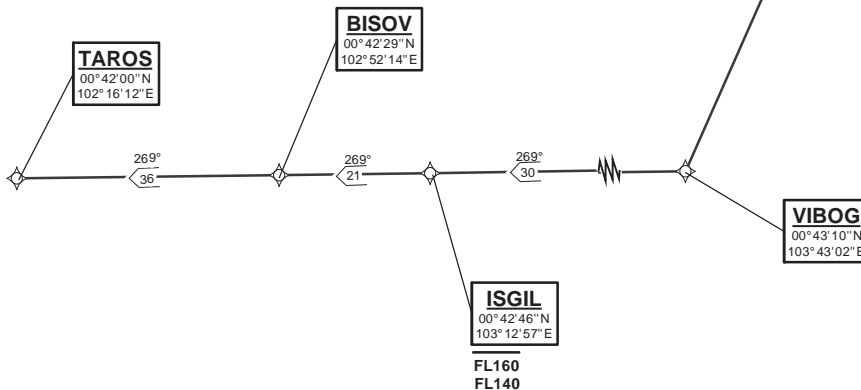

NOT TO SCALE

31 OCT 2024

TAROS 1D (SID) RNAV GNSS RWY 20L - DESCRIPTIONS**Formal & Abbreviated Descriptions**

Formal Description	Abbreviated Description	Path Terminator	Fly-Over required
To UKIBO on course 203°.	UKIBO [M203] -	CF	N
To VIGUD at or above 2500ft, turn right.	VIGUD [A025+; R] -	TF	N
To SAMKO at or above 4000ft, turn left.	SAMKO [A040+; L] -	TF	N
To VIBOG, turn right.	VIBOG [R] -	TF	N
To ISGIL, between FL140 to FL160.	ISGIL [FL140+; FL160-] -	TF	N
To BISOV.	BISOV -	TF	N
To TAROS.	TAROS	TF	N

Tabular Descriptions

Path Term	Waypoint Name	Fly-Over	Course °M(°T)	Distance (NM)	Turn Direction	Altitude	Speed Limit	Navigation Spec
CF	UKIBO	Y	203(203.4)	1.5	-	-	-	RNAV1
TF	VIGUD	-	203(203.4)	5.0	R	A025+	-	RNAV1
TF	SAMKO	-	210(210.4)	9.0	L	A040+	-	RNAV1
TF	VIBOG	-	204(204.4)	24.0	R	-	-	RNAV1
TF	ISGIL	-	269(269.4)	30.0	-	FL140+ FL160-	-	RNAV1
TF	BISOV	-	269(269.4)	21.0	-	-	-	RNAV1
TF	TAROS	-	269(269.4)	36.0	-	-	-	RNAV1

Radio Communications Failure Procedure

1	SET TRANSPONDER TO MODE A/C CODE 7600
2	COMMUNICATIONS FAILURE OCCURS IMMEDIATELY AFTER DEPARTURE: PROCEED DIRECT TO SAMKO HOLDING AREA (SHA) CLIMBING TO THE LAST ASSIGNED ALTITUDE, THEREAFTER REFER TO SINGAPORE AIP ON RADIO COMMUNICATIONS FAILURE PROCEDURE.

STANDARD DEPARTURE CHART
RNAV (GNSS) -
INSTRUMENT (SID)

TWR 118.6 / 118.25
APP 120.3
124.05
ACC 133.25

TRANSITION ALTITUDE
11 000ft

D-ATIS AP ID-WSSS
128.6

SINGAPORE/Singapore Changi
RWY 02L
TAROS DEPARTURES
TAROS 1E

ELEV, ALT IN FEET

BEARINGS, TRACKS AND
RADIALS ARE MAGNETIC
VAR 0°23'E (2020)

DISTANCES IN NM

GENERAL INFORMATION

INITIAL CLIMB
3000FT

CAUTION: RWY 02R/20L NOT AVAILABLE FOR CIVIL USE UNTIL FURTHER ADVISED

NOTE: RADAR REQUIRED

NOTE: RNAV-1 NAVIGATION SPECIFICATION GNSS REQUIRED

NOTE: ACFT UNABLE TO FLY THE SID PROFILE
SHALL INFORM ATC PRIOR TO DEPARTURE AND
EXPECT RADAR VECTORED IF NECESSARY

NOTE: WHEN TAKEN OFF THE SID, AS INSTRUCTED BY ATC,
REFER TO ENR 1.5, SECTION 3, PARAGRAPH 3.2 [A]
- FOR RWY 02L MINIMUM CLIMB GRADIENT

NOTE: REFER TO BACK PAGE FOR
- FORMAL AND TABULAR DESCRIPTIONS
- RADIO COM FAILURE PROCEDURES

PROCEDURE INFORMATION

SID SHALL NOT EXCEED IAS 230KTS UNTIL
PASSING 4000FT AMSL AND NOT EXCEED
IAS 250KTS UNTIL PASSING 10000FT AMSL.

CRUISING LEVELS WILL BE ISSUED AFTER TAKE-OFF
BY SINGAPORE RADAR.

SID SHALL BE ON A MINIMUM CLIMB GRADIENT OF 5%
UNTIL REACHING OR PASSING 2500FT, THEREAFTER 3.3%.

GND SPEED - KNOTS	75	100	150	200	250	300
5% V/V (fpm)	380	506	760	1013	1266	1519
3.3% V/V (fpm)	251	334	501	668	835	1003

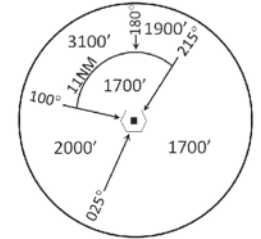

MSA 25 NM
from TEKONG DVOR

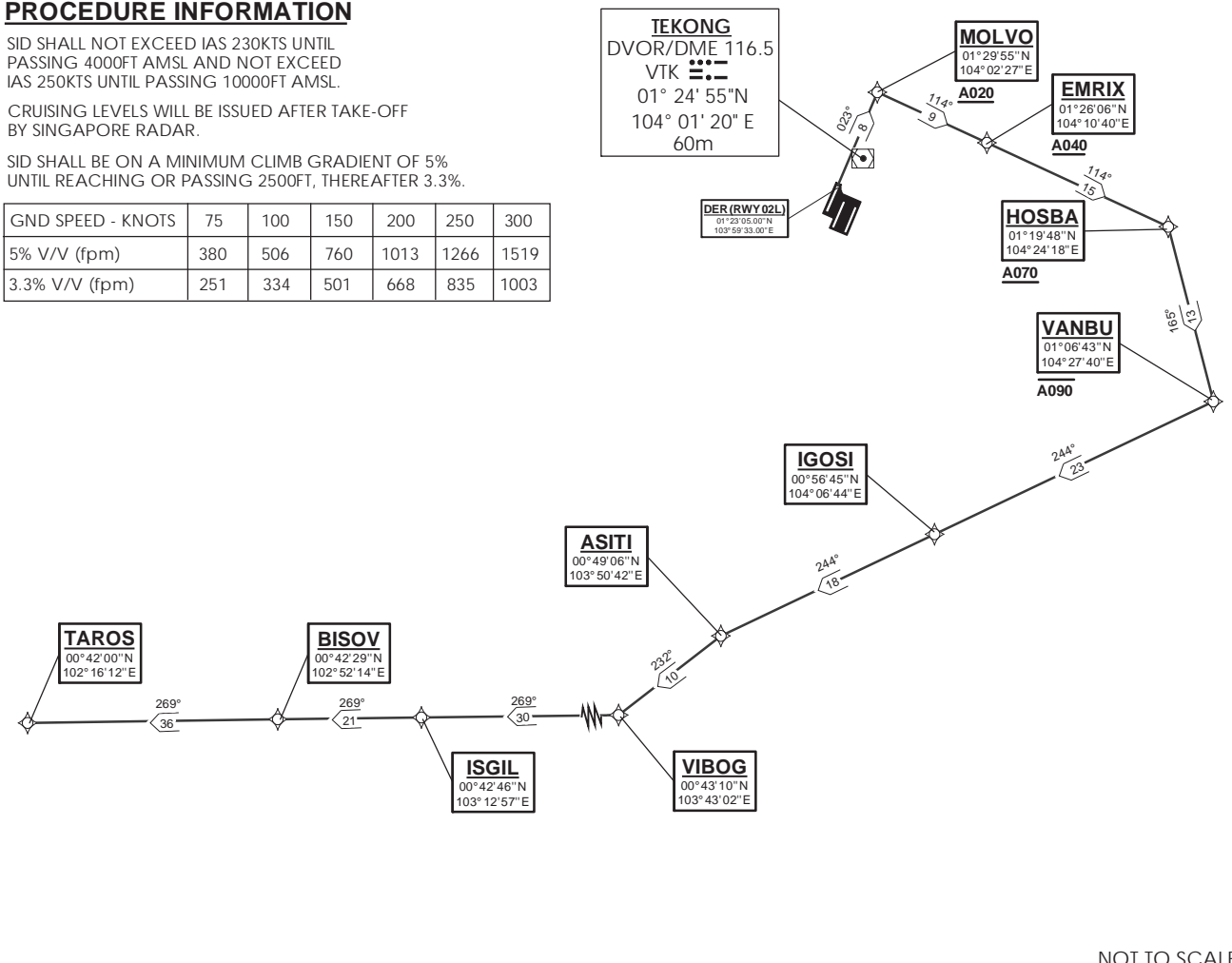

NOT TO SCALE

TAROS 1E (SID) RNAV GNSS RWY 02L - DESCRIPTIONS

Formal & Abbreviated Descriptions

Formal Description	Abbreviated Description	Path Terminator	Fly-Over required
To MOLVO on course 023° at or above 2000ft, turn right.	MOLVO [M023; A020+; R] -	CF	N
To EMRIX at or above 4000ft.	EMRIX [A040+] -	TF	N
To HOSBA at or above 7000ft, turn right.	HOSBA [A070+; R] -	TF	N
To VANBU at or below 9000ft, turn right.	VANBU [A090-; R] -	TF	N
To IGOSI.	IGOSI -	TF	N
To ASITI, turn left.	ASITI [L] -	TF	N
To VIBOG, turn right.	VIBOG [R] -	TF	N
To ISGIL.	ISGIL -	TF	N
To BISOV.	BISOV -	TF	N
To TAROS.	TAROS	TF	N

Tabular Descriptions

Path Term	Waypoint Name	Fly-Over	Course °M(°T)	Distance (NM)	Turn Direction	Altitude	Speed Limit	Navigation Spec
CF	MOLVO	-	023(023.4)	8.0	R	A020+	-	RNAV1
TF	EMRIX	-	114(114.4)	9.0	-	A040+	-	RNAV1
TF	HOSBA	-	114(114.4)	15.0	R	A070+	-	RNAV1
TF	VANBU	-	165(165.4)	13.0	R	A090-	-	RNAV1
TF	IGOSI	-	244(244.4)	23.0	-	-	-	RNAV1
TF	ASITI	-	244(244.4)	18.0	L	-	-	RNAV1
TF	VIBOG	-	232(232.3)	10.0	R	-	-	RNAV1
TF	ISGIL	-	269(269.4)	30.0	-	-	-	RNAV1
TF	BISOV	-	269(269.4)	21.0	-	-	-	RNAV1
TF	TAROS	-	269(269.4)	36.0	-	-	-	RNAV1

Radio Communications Failure Procedure

1	SET TRANSPONDER TO MODE A/C CODE 7600
2	<p>COMMUNICATIONS FAILURE OCCURS IMMEDIATELY AFTER DEPARTURE:</p> <p>PROCEED DIRECT TO NYLON HOLDING AREA (NHA) CLIMBING TO THE LAST ASSIGNED ALTITUDE, THEREAFTER REFER TO SINGAPORE AIP ON RADIO COMMUNICATIONS FAILURE PROCEDURE.</p>

STANDARD DEPARTURE CHART
RNAV (GNSS) -
INSTRUMENT (SID)

TWR 118.6 / 118.25
APP 120.3
124.05
ACC 133.25

TRANSITION ALTITUDE
11 000ft

D-ATIS AP ID-WSSS
128.6

SINGAPORE/Singapore Changi
RWY 20R
TAROS DEPARTURES
TAROS 1F

ELEV, ALT IN FEET

BEARINGS, TRACKS AND
RADIALS ARE MAGNETIC
VAR 0°23'E (2020)

DISTANCES IN NM

GENERAL INFORMATION

INITIAL CLIMB
3000FT

CAUTION: RWY 02R/20L NOT AVAILABLE FOR CIVIL USE UNTIL FURTHER ADVISED

NOTE: RADAR REQUIRED

NOTE: RNAV-1 NAVIGATION SPECIFICATION GNSS REQUIRED

NOTE: ACFT UNABLE TO FLY THE SID PROFILE SHALL INFORM ATC PRIOR TO DEPARTURE AND EXPECT RADAR VECTORING IF NECESSARY

NOTE: WHEN TAKEN OFF THE SID, AS INSTRUCTED BY ATC, REFER TO ENR 1.5, SECTION 3, PARAGRAPH 3.4.2 - FOR RWY 20R MINIMUM CLIMB GRADIENT

NOTE: REFER TO BACK PAGE FOR
- FORMAL AND TABULAR DESCRIPTIONS
- RADIO COM FAILURE PROCEDURES

PROCEDURE INFORMATION

SID SHALL NOT EXCEED IAS 230KTS UNTIL PASSING 4000FT AMSL AND NOT EXCEED IAS 250KTS UNTIL PASSING 10000FT AMSL.

CRUISING LEVELS WILL BE ISSUED AFTER TAKE-OFF BY SINGAPORE RADAR.

SID SHALL BE ON A MINIMUM CLIMB GRADIENT OF 6% UNTIL REACHING OR PASSING 2500FT, THEREAFTER 3.3%.

GND SPEED - KNOTS	75	100	150	200	250	300
6% V/V (fpm)	456	608	911	1215	1518	1821
3.3% V/V (fpm)	251	334	501	668	835	1003

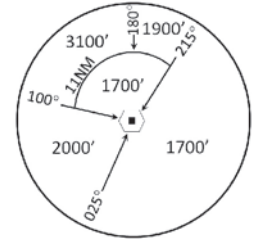

TEKONG
DVOR/DME 116.5
VTK
01° 24' 55"N
104° 01' 20" E
60m

DER (RWY 20R)
01° 20' 47.00"N
103° 58' 35.00"E

LEDOX
01° 16' 42"N
103° 56' 51"E
A015

LETGO
01° 14' 11"N
103° 55' 48"E
A025

SAMKO
01° 05' 30"N
103° 52' 55"E
A040

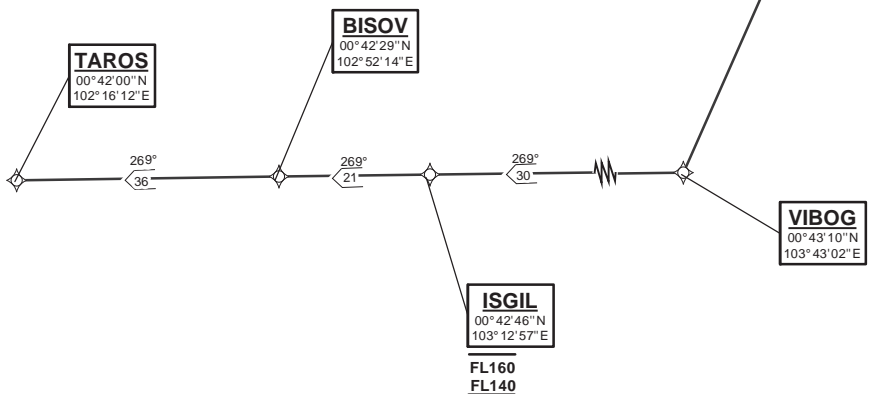

NOT TO SCALE

31 OCT 2024

TAROS 1F (SID) RNAV GNSS RWY 20R - DESCRIPTIONS**Formal & Abbreviated Descriptions**

Formal Description	Abbreviated Description	Path Terminator	Fly-Over required
To LEDOX on course 203° at or above 1500ft.	LEDOX [M203; A015+] -	CF	N
To LETGO at or above 2500ft, turn left.	LETGO [A025+; L] -	TF	N
To SAMKO at or above 4000ft, turn right.	SAMKO [A040+; R] -	TF	N
To VIBOG, turn right.	VIBOG [R] -	TF	N
To ISGIL, between FL140 to FL160.	ISGIL [FL140+; FL160-] -	TF	N
To BISOV.	BISOV -	TF	N
To TAROS.	TAROS	TF	N

Tabular Descriptions

Path Term	Waypoint Name	Fly-Over	Course °M(°T)	Distance (NM)	Turn Direction	Altitude	Speed Limit	Navigation Spec
CF	LEDOX	-	203(203.4)	5.0	-	A015+	-	RNAV1
TF	LETGO	-	203(203.4)	3.0	L	A025+	-	RNAV1
TF	SAMKO	-	198(198.4)	9.0	R	A040+	-	RNAV1
TF	VIBOG	-	204(204.4)	24.0	R	-	-	RNAV1
TF	ISGIL	-	269(269.4)	30.0	-	FL140+ FL160-	-	RNAV1
TF	BISOV	-	269(269.4)	21.0	-	-	-	RNAV1
TF	TAROS	-	269(269.4)	36.0	-	-	-	RNAV1

Radio Communications Failure Procedure

1	SET TRANSPONDER TO MODE A/C CODE 7600
2	COMMUNICATIONS FAILURE OCCURS IMMEDIATELY AFTER DEPARTURE: PROCEED DIRECT TO SAMKO HOLDING AREA (SHA) CLIMBING TO THE LAST ASSIGNED ALTITUDE, THEREAFTER REFER TO SINGAPORE AIP ON RADIO COMMUNICATIONS FAILURE PROCEDURE.

STANDARD DEPARTURE CHART
RNAV (GNSS) -
INSTRUMENT (SID)

TWR 118.6 / 118.25
APP 120.3
124.05
ACC 134.2

TRANSITION ALTITUDE
11 000ft

D-ATIS AP ID-WSSS
128.6

SINGAPORE/Singapore Changi
RWY 02C
TOMAN DEPARTURES
TOMAN 3A

ELEV, ALT IN FEET
BEARINGS, TRACKS AND
RADIALS ARE MAGNETIC
VAR 23°E (2020)

DISTANCES IN NM

CAUTION: RWY 02R/20L NOT AVAILABLE FOR CIVIL USE UNTIL FURTHER ADVISED

NOTE: RADAR REQUIRED

NOTE: RNAV-1 NAVIGATION SPECIFICATION
GNSS REQUIRED

NOTE: CLOSE-IN OBSTACLES (AIRCRAFT UP TO 80FT)
EXIST ON TAXIWAYS WEST OF RUNWAY 02C

NOTE: ACFT UNABLE TO FLY THE SID
PROFILE SHALL INFORM ATC
PRIOR TO DEPARTURE AND TO
EXPECT RADAR VECTORED,
IF NECESSARY

NOTE: WHEN TAKEN OFF THE SID,
AS INSTRUCTED BY ATC,
REFER TO ENR 1.5, SECTION 3,
PARAGRAPH 3.3 [A] - FOR RWY 02C MINIMUM CLIMB GRADIENT

NOTE: REFER TO BACK PAGE FOR
- FORMAL AND TABULAR DESCRIPTIONS
- RADIO COM FAILURE PROCEDURES

GENERAL INFORMATION

INITIAL CLIMB
3000FT

ALL SIDs INCLUDE NOISE PREFERENTIAL ROUTES.

RWY 02C

SID SHALL NOT EXCEED IAS 230KTS UNTIL PASSING 4000FT AMSL AND NOT EXCEED IAS 250KTS UNTIL PASSING 10000FT AMSL.

CRUISING LEVELS WILL BE ISSUED AFTER TAKE-OFF BY SINGAPORE RADAR.

SID SHALL BE ON A MINIMUM CLIMB GRADIENT OF 5% UNTIL REACHING OR PASSING 2500FT, THEREAFTER 3.3%.

GND SPEED - KNOTS	75	100	150	200	250	300
5% V/V (fpm)	380	506	760	1013	1266	1519
3.3% V/V (fpm)	251	334	501	668	835	1003

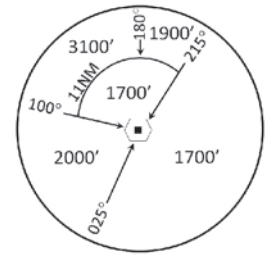

MSA 25 NM
from TEKONG DVOR

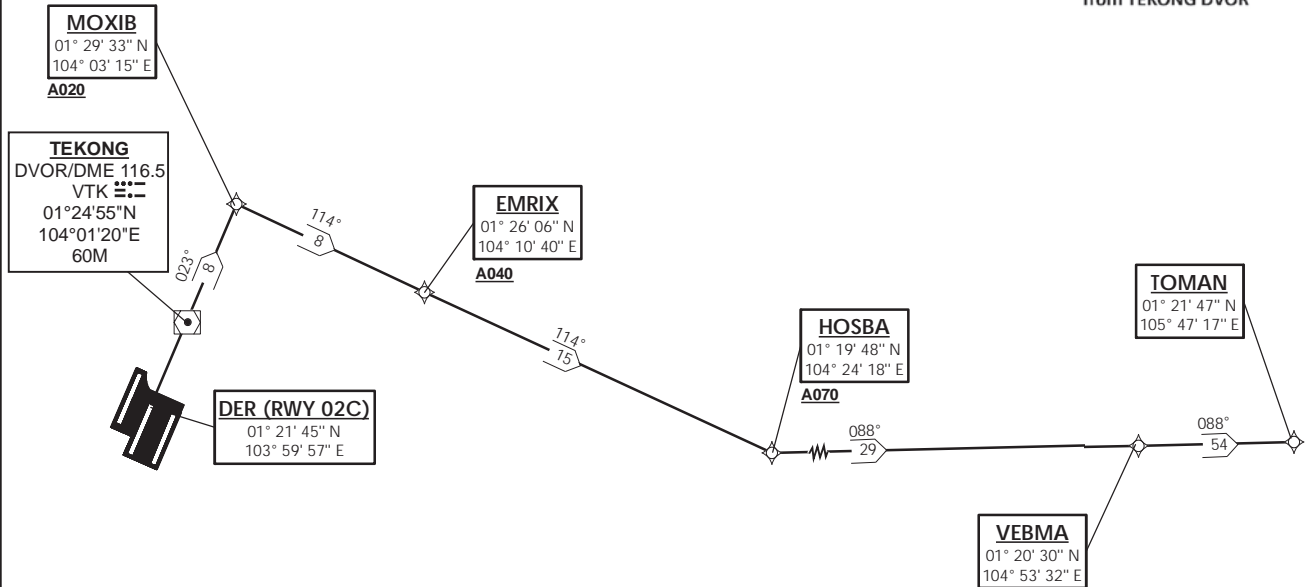

NOT TO SCALE

TOMAN 3A (SID) RNAV GNSS RWY 02C - DESCRIPTIONS

Formal & Abbreviated Descriptions

Formal Description	Abbreviated Description	Path Terminator	Fly-Over required
To MOXIB on course 023° at or above 2000ft, turn right.	MOXIB [M023; A020+; R] -	CF	N
To EMRIX at or above 4000ft.	EMRIX [A040+] -	TF	N
To HOSBA at or above 7000ft, turn left.	HOSBA [A070+; L] -	TF	N
To VEBMA.	VEBMA -	TF	N
To TOMAN.	TOMAN	TF	N

Tabular Descriptions

Path Term	Waypoint Name	Fly-Over	Course °M(°T)	Distance (NM)	Turn Direction	Altitude	Speed Limit	Navigation Spec
CF	MOXIB	-	023(023.4)	8.0	R	A020+	-	RNAV1
TF	EMRIX	-	114(114.4)	8.0	-	A040+	-	RNAV1
TF	HOSBA	-	114(114.4)	15.0	L	A070+	-	RNAV1
TF	VEBMA	-	088(088.4)	29.0	-	-	-	RNAV1
TF	TOMAN	-	088(088.4)	54.0	-	-	-	RNAV1

Radio Communications Failure Procedure

1	SET TRANSPONDER TO MODE A/C CODE 7600
2	<p>COMMUNICATIONS FAILURE OCCURS IMMEDIATELY AFTER DEPARTURE:</p> <p>PROCEED DIRECT TO NYLON HOLDING AREA (NHA) CLIMBING TO THE LAST ASSIGNED ALTITUDE, THEREAFTER REFER TO SINGAPORE AIP ON RADIO COMMUNICATIONS FAILURE PROCEDURE.</p>

**STANDARD DEPARTURE CHART
RNAV (GNSS) -
INSTRUMENT (SID)**

TWR 118.6 / 118.25
APP 120.3
124.05
ACC 134.2

TRANSITION ALTITUDE
11 000ft

D-ATIS AP ID-WSSS
128.6

**SINGAPORE/Singapore Changi
RWY 20C
TOMAN DEPARTURES
TOMAN 5B**

ELEV, ALT IN FEET
BEARINGS, TRACKS AND
RADIALS ARE MAGNETIC
VAR 0°23'E (2022)

DISTANCES IN NM

GENERAL INFORMATION

**INITIAL CLIMB
3000FT**

CAUTION: RWY 02R/20L NOT AVAILABLE FOR CIVIL USE UNTIL FURTHER ADVISED

NOTE: RADAR REQUIRED

NOTE: RNAV-1 NAVIGATION SPECIFICATION GNSS REQUIRED

NOTE: ACFT UNABLE TO FLY THE SID PROFILE
SHALL INFORM ATC PRIOR TO DEPARTURE AND
EXPECT RADAR VECTORED IF NECESSARY

NOTE: WHEN TAKEN OFF THE SID, AS INSTRUCTED BY ATC,
REFER TO ENR 1.5, SECTION 3, PARAGRAPH 3.4.1
- FOR RWY 20C MINIMUM CLIMB GRADIENT

NOTE: REFER TO BACK PAGE FOR
- FORMAL AND TABULAR DESCRIPTIONS
- RADIO COM FAILURE PROCEDURES

PROCEDURE INFORMATION

SID SHALL NOT EXCEED IAS 230KTS UNTIL
PASSING 4000FT AMSL AND NOT EXCEED
IAS 250KTS UNTIL PASSING 10000FT AMSL.

CRUISING LEVELS WILL BE ISSUED AFTER TAKE-OFF
BY SINGAPORE RADAR.

SID SHALL BE ON A MINIMUM CLIMB GRADIENT OF 7%
UNTIL REACHING OR PASSING 2500FT, THEREAFTER 3.3%.

GND SPEED - KNOTS	75	100	150	200	250	300
7% V/V (fpm)	532	709	1063	1418	1772	2127
3.3% V/V (fpm)	251	334	501	668	835	1003

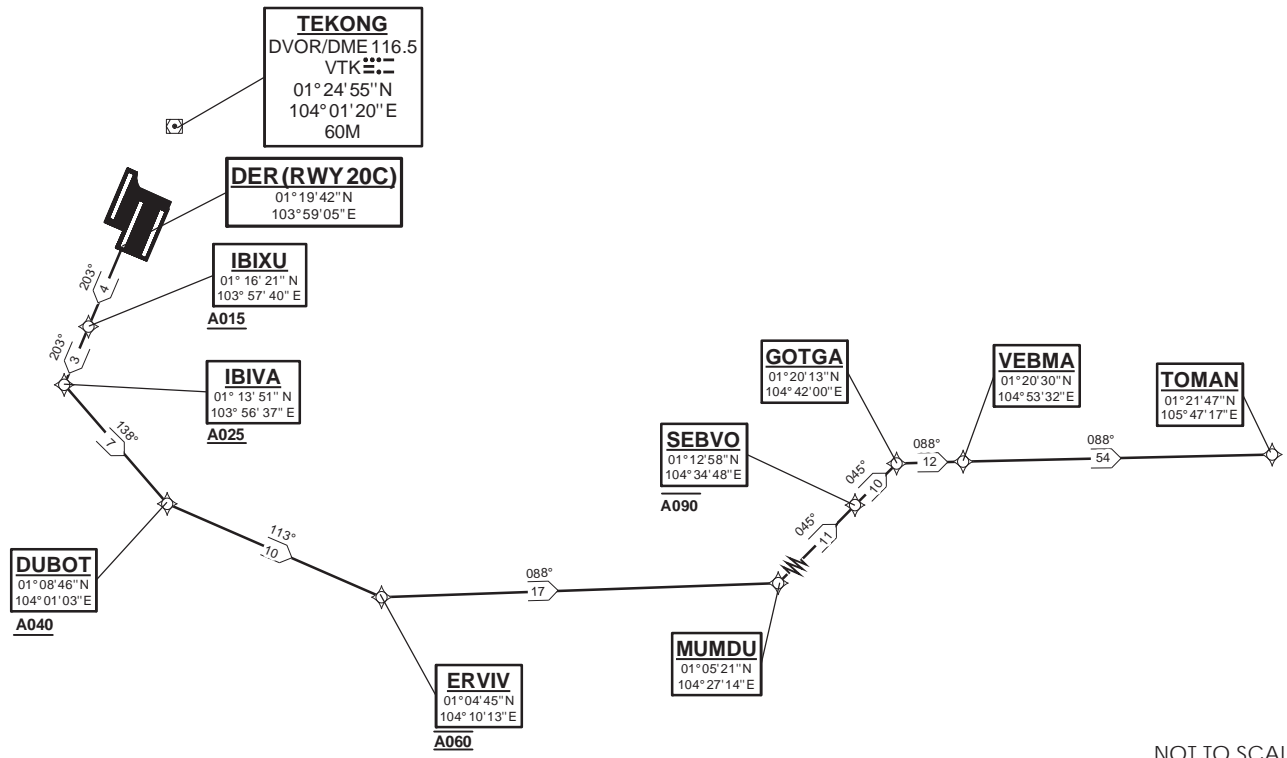
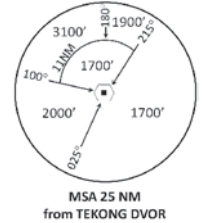

NOT TO SCALE

TOMAN 5B (SID) RNAV GNSS RWY 20C - DESCRIPTIONS

Formal & Abbreviated Descriptions

Formal Description	Abbreviated Description	Path Terminator	Fly-Over required
To IBIXU on course 203° at or above 1500ft.	IBIXU [M203; A015+] -	CF	N
To IBIVA at or above 2500ft, turn left.	IBIVA [A025+; L] -	TF	N
To DUBOT at or above 4000ft, turn left.	DUBOT [A040+; L] -	TF	N
To ERVIV at 6000ft, turn left.	ERVIV [@A060; L] -	TF	N
To MUMDU, turn left.	MUMDU [L] -	TF	N
To SEBVO at or below 9000ft.	SEBVO [A090-] -	TF	N
To GOTGA, turn right.	GOTGA [R] -	TF	N
To VEBMA.	VEBMA -	TF	N
To TOMAN.	TOMAN	TF	N

Tabular Descriptions

Path Term	Waypoint Name	Fly-Over	Course °M(°T)	Distance (NM)	Turn Direction	Altitude	Speed Limit	Navigation Spec
CF	IBIXU	-	203(203.4)	4.0	-	A015+	-	RNAV1
TF	IBIVA	-	203(203.4)	3.0	L	A025+	-	RNAV1
TF	DUBOT	-	138(138.4)	7.0	L	A040+	-	RNAV1
TF	ERVIV	-	113(113.4)	10.0	L	@A060	-	RNAV1
TF	MUMDU	-	088(088.4)	17.0	L	-	-	RNAV1
TF	SEBVO	-	045(045.4)	11.0	-	A090-	-	RNAV1
TF	GOTGA	-	045(045.4)	10.0	R	-	-	RNAV1
TF	VEBMA	-	088(088.4)	12.0	-	-	-	RNAV1
TF	TOMAN	-	088(088.4)	54.0	-	-	-	RNAV1

Radio Communications Failure Procedure

1	SET TRANSPONDER TO MODE A/C CODE 7600
2	COMMUNICATIONS FAILURE OCCURS IMMEDIATELY AFTER DEPARTURE: PROCEED DIRECT TO SAMKO HOLDING AREA (SHA) CLIMBING TO THE LAST ASSIGNED ALTITUDE, THEREAFTER REFER TO SINGAPORE AIP ON RADIO COMMUNICATIONS FAILURE PROCEDURE.

STANDARD DEPARTURE CHART
RNAV (GNSS) -
INSTRUMENT (SID)

SINGAPORE/Singapore Changi
RWY 02R
TOMAN DEPARTURES (RADAR)
TOMAN 1C

TWR 118.6 / 118.25
APP 120.3
124.05
ACC 134.2

TRANSITION ALTITUDE
11 000ft

D-ATIS AP ID-WSSSS
128.6

PROCEDURE INFORMATION

SID SHALL NOT EXCEED IAS 230KTS UNTIL PASSING 4000FT AMSL AND NOT EXCEED IAS 250KTS UNTIL PASSING 10000FT AMSL.
CRUISING LEVELS WILL BE ISSUED AFTER TAKE-OFF BY SINGAPORE RADAR.
SID SHALL BE ON A MINIMUM CLIMB GRADIENT OF 5% UNTIL REACHING OR PASSING 2500FT, THEREAFTER 3.3%.

GND SPEED - KNOTS	75	100	150	200	250	300
5% V/V (fpm)	380	506	760	1013	1266	1519
3.3% V/V (fpm)	251	334	501	668	835	1003

TEKONG
DVOR/DME 116.5
VTK
01° 24' 55"N
104° 01' 20" E
60m

GENERAL INFORMATION

INITIAL CLIMB
3000FT

CAUTION: RWY 02R/20L NOT AVAILABLE FOR CIVIL USE UNTIL FURTHER ADVISED

- NOTE:** RADAR REQUIRED
- NOTE:** RNAV-1 NAVIGATION SPECIFICATION GNSS REQUIRED
- NOTE:** ACFT UNABLE TO FLY THE SID PROFILE SHALL INFORM ATC PRIOR TO DEPARTURE AND EXPECT RADAR VECTORING IF NECESSARY
- NOTE:** WHEN TAKEN OFF THE SID, AS INSTRUCTED BY ATC, REFER TO ENR 1.5, SECTION 3, PARAGRAPH 3.5
- FOR RWY 02R MINIMUM CLIMB GRADIENT
- NOTE:** REFER TO BACK PAGE FOR
- FORMAL AND TABULAR DESCRIPTIONS
- RADIO COM FAILURE PROCEDURES

ELEV, ALT IN FEET

BEARINGS, TRACKS AND RADIALS ARE MAGNETIC
VAR 0°23'E (2020)

DISTANCES IN NM

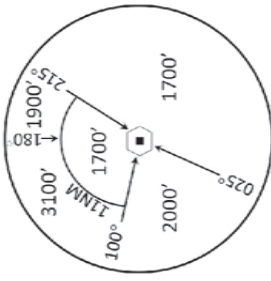

MSA 25 NM
from **TEKONG DVOR**

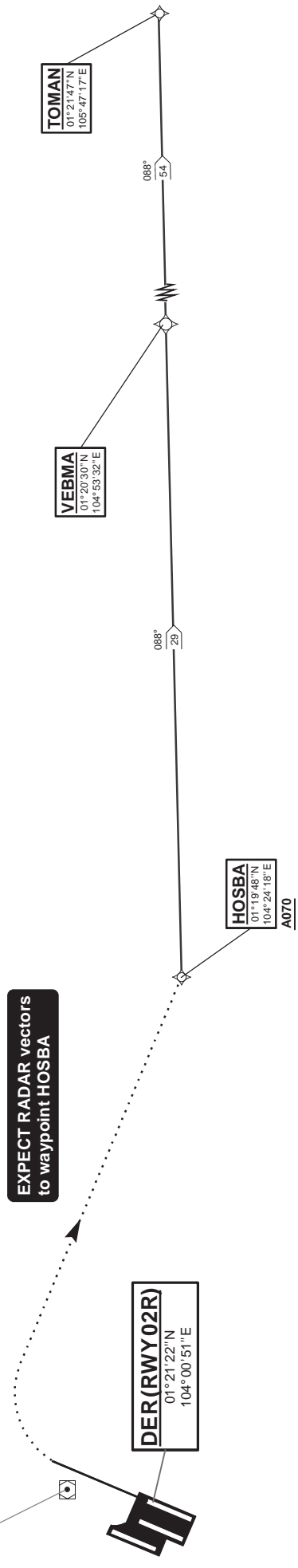

NOT TO SCALE

31 OCT 2024

TOMAN 1C (SID) RNAV GNSS RWY 02R - DESCRIPTIONS**Formal & Abbreviated Descriptions**

Formal Description	Abbreviated Description	Path Terminator	Fly-Over required
Climb heading 023°, Gradient 5% to 2500ft, thence 3.3%. Expect radar vectors to waypoint HOSBA.	-	VA	N
To HOSBA at or above 7000ft.	HOSBA [A070+] -	DF	N
To VEBMA.	VEBMA -	TF	N
To TOMAN.	TOMAN	TF	N

Tabular Descriptions

Path Term	Waypoint Name	Fly-Over	Course °M(°T)	Distance (NM)	Turn Direction	Altitude	Speed Limit	Navigation Spec
VA	-	-	023(023.4)	-	-	A030	-	RNAV1
DF	HOSBA	-	-	-	-	A070+	-	RNAV1
TF	VEBMA	-	088(088.4)	29.0	-	-	-	RNAV1
TF	TOMAN	-	088(088.4)	54.0	-	-	-	RNAV1

Radio Communications Failure Procedure

1	SET TRANSPONDER TO MODE A/C CODE 7600
2	COMMUNICATIONS FAILURE OCCURS IMMEDIATELY AFTER DEPARTURE: PROCEED DIRECT TO NYLON HOLDING AREA (NHA) CLIMBING TO THE LAST ASSIGNED ALTITUDE, THEREAFTER REFER TO SINGAPORE AIP ON RADIO COMMUNICATIONS FAILURE PROCEDURE.

STANDARD DEPARTURE CHART
RNAV (GNSS) -
INSTRUMENT (SID)

SINGAPORE/Singapore Changi
RWY 20L
TOMAN DEPARTURES
TOMAN 1D

TWR 118.6 / 118.25
APP 120.3
ACC 134.2

TRANSITION ALTITUDE
11 000ft

D-ATIS AP ID-WSSS
128.6

GENERAL INFORMATION

INITIAL CLIMB
3000FT

CAUTION: RWY 02R/20L NOT AVAILABLE FOR CIVIL USE UNTIL FURTHER ADVISED

- NOTE:** RADAR REQUIRED
- NOTE:** RNAV-1 NAVIGATION SPECIFICATION GNSS REQUIRED
- NOTE:** ACFT UNABLE TO FLY THE SID PROFILE SHALL INFORM ATC PRIOR TO DEPARTURE AND EXPECT RADAR VECTORING IF NECESSARY
- NOTE:** WHEN TAKEN OFF THE SID, AS INSTRUCTED BY ATC, REFER TO ENR 1.5, SECTION 3, PARAGRAPH 3.4.3 - FOR RWY 20L MINIMUM CLIMB GRADIENT
- NOTE:** REFER TO BACK PAGE FOR
 - FORMAL AND TABULAR DESCRIPTIONS
 - RADIO COM FAILURE PROCEDURES

TEKONG
DVOR/DME 116.5
VTK
01° 24' 55"N
104° 01' 20" E
60m

DER (RWY 20L)
01° 19' 19"N
103° 59' 59"E

UKIBO
01° 17' 58"N
103° 59' 24"E

DUBOI
01° 08' 46"N
104° 01' 03"E
A040

ERVIV
01° 04' 45"N
104° 10' 13"E
A060

PROCEDURE INFORMATION

SID SHALL NOT EXCEED IAS 230KTS UNTIL PASSING 4000FT AMSL AND NOT EXCEED IAS 250KTS UNTIL PASSING 10000FT AMSL.

CRUISING LEVELS WILL BE ISSUED AFTER TAKE-OFF BY SINGAPORE RADAR.

SID SHALL BE ON A MINIMUM CLIMB GRADIENT OF 9% UNTIL REACHING OR PASSING 2500FT, THEREAFTER 3.3%.

GND SPEED - KNOTS	75	100	150	200	250	300
9% V/V (fpm)	684	911	1367	1823	2279	2734
3.3% V/V (fpm)	251	334	501	668	835	1003

ELEV, ALT IN FEET

BEARINGS, TRACKS AND RADIALS ARE MAGNETIC
VAR 0°23'E (2020)

DISTANCES IN NM

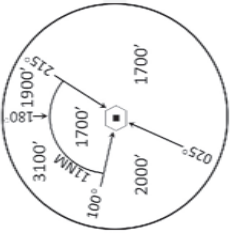

MSA 25 NM
from TEKONG DVOR

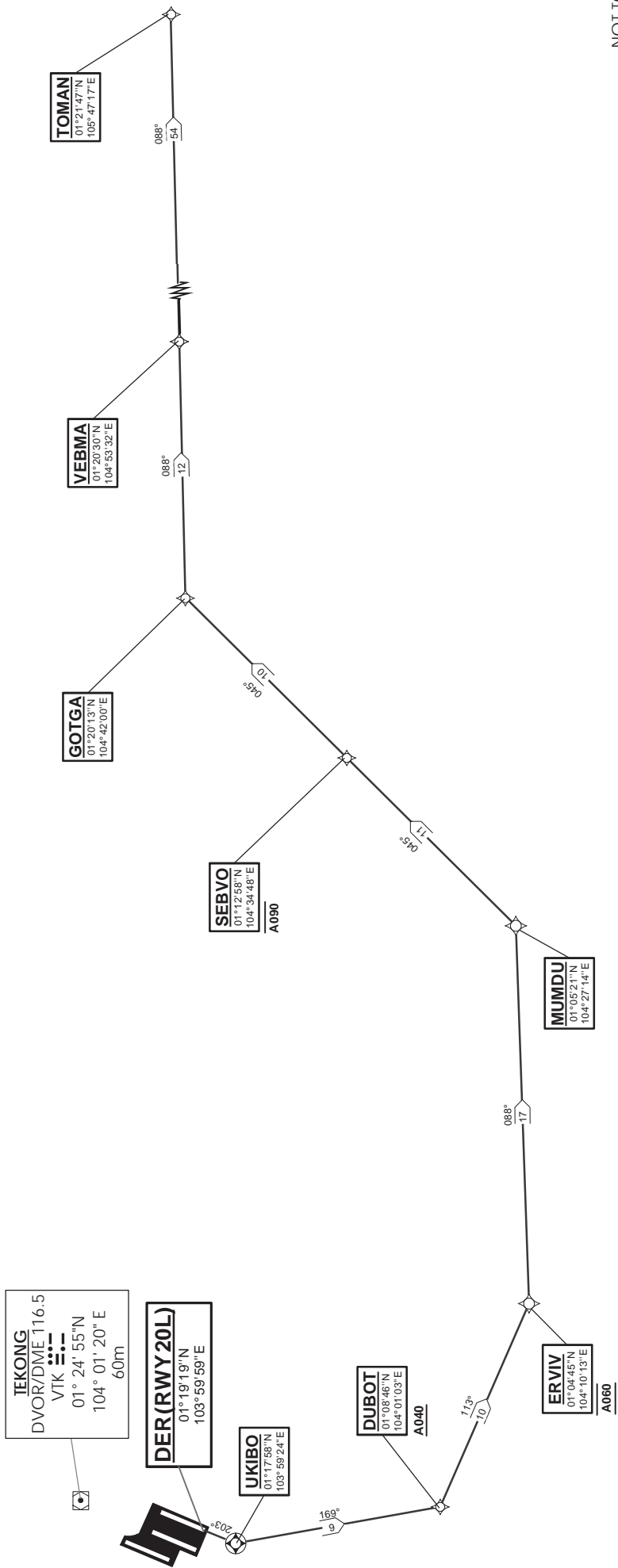

NOT TO SCALE

31 OCT 2024

TOMAN 1D (SID) RNAV GNSS RWY 20L - DESCRIPTIONS**Formal & Abbreviated Descriptions**

Formal Description	Abbreviated Description	Path Terminator	Fly-Over required
To UKIBO on course 203°, turn left.	UKIBO [M203; L] -	CF	N
To DUBOT at or above 4000ft, turn left.	DUBOT [A040+; L] -	TF	N
To ERVIV at 6000ft, turn left.	ERVIV [@A060; L] -	TF	N
To MUMDU, turn left.	MUMDU [L] -	TF	N
To SEBVO at or below 9000ft.	SEBVO [A090-] -	TF	N
To GOTGA, turn right.	GOTGA [R] -	TF	N
To VEBMA.	VEBMA -	TF	N
To TOMAN.	TOMAN	TF	N

Tabular Descriptions

Path Term	Waypoint Name	Fly-Over	Course °M(°T)	Distance (NM)	Turn Direction	Altitude	Speed Limit	Navigation Spec
CF	UKIBO	Y	203(203.4)	1.5	L	-	-	RNAV1
TF	DUBOT	-	169(169.4)	9.0	L	A040+	-	RNAV1
TF	ERVIV	-	113(113.4)	10.0	L	@A060	-	RNAV1
TF	MUMDU	-	088(088.4)	17.0	L	-	-	RNAV1
TF	SEBVO	-	045(045.4)	11.0	-	A090-	-	RNAV1
TF	GOTGA	-	045(045.4)	10.0	R	-	-	RNAV1
TF	VEBMA	-	088(088.4)	12.0	-	-	-	RNAV1
TF	TOMAN	-	088(088.4)	54.0	-	-	-	RNAV1

Radio Communications Failure Procedure

1	SET TRANSPONDER TO MODE A/C CODE 7600
2	COMMUNICATIONS FAILURE OCCURS IMMEDIATELY AFTER DEPARTURE: PROCEED DIRECT TO SAMKO HOLDING AREA (SHA) CLIMBING TO THE LAST ASSIGNED ALTITUDE, THEREAFTER REFER TO SINGAPORE AIP ON RADIO COMMUNICATIONS FAILURE PROCEDURE.

STANDARD DEPARTURE CHART
RNAV (GNSS) -
INSTRUMENT (SID)

TWR 118.6 / 118.25
APP 120.3
124.05
ACC 134.2

TRANSITION ALTITUDE
11 000ft

D-ATIS AP ID-WSSS
128.6

SINGAPORE/Singapore Changi
RWY 02L
TOMAN DEPARTURES
TOMAN 3E

ELEV, ALT IN FEET
BEARINGS, TRACKS AND
RADIALS ARE MAGNETIC
VAR 0°23'E (2020)

DISTANCES IN NM

GENERAL INFORMATION

INITIAL CLIMB
3000FT

CAUTION: RWY 02R/20L NOT AVAILABLE FOR CIVIL USE UNTIL FURTHER ADVISED

NOTE: RADAR REQUIRED

NOTE: RNAV-1 NAVIGATION SPECIFICATION GNSS REQUIRED

NOTE: ACFT UNABLE TO FLY THE SID PROFILE
SHALL INFORM ATC PRIOR TO DEPARTURE AND
EXPECT RADAR VECTORED IF NECESSARY

NOTE: WHEN TAKEN OFF THE SID, AS INSTRUCTED BY ATC,
REFER TO ENR 1.5, SECTION 3, PARAGRAPH 3.2 [A]
- FOR RWY 02L MINIMUM CLIMB GRADIENT

NOTE: REFER TO BACK PAGE FOR
- FORMAL AND TABULAR DESCRIPTIONS
- RADIO COM FAILURE PROCEDURES

PROCEDURE INFORMATION

SID SHALL NOT EXCEED IAS 230KTS UNTIL
PASSING 4000FT AMSL AND NOT EXCEED
IAS 250KTS UNTIL PASSING 10000FT AMSL.

CRUISING LEVELS WILL BE ISSUED AFTER TAKE-OFF
BY SINGAPORE RADAR.

SID SHALL BE ON A MINIMUM CLIMB GRADIENT OF 5%
UNTIL REACHING OR PASSING 2500FT, THEREAFTER 3.3%.

GND SPEED - KNOTS	75	100	150	200	250	300
5% V/V (fpm)	380	506	760	1013	1266	1519
3.3% V/V (fpm)	251	334	501	668	835	1003

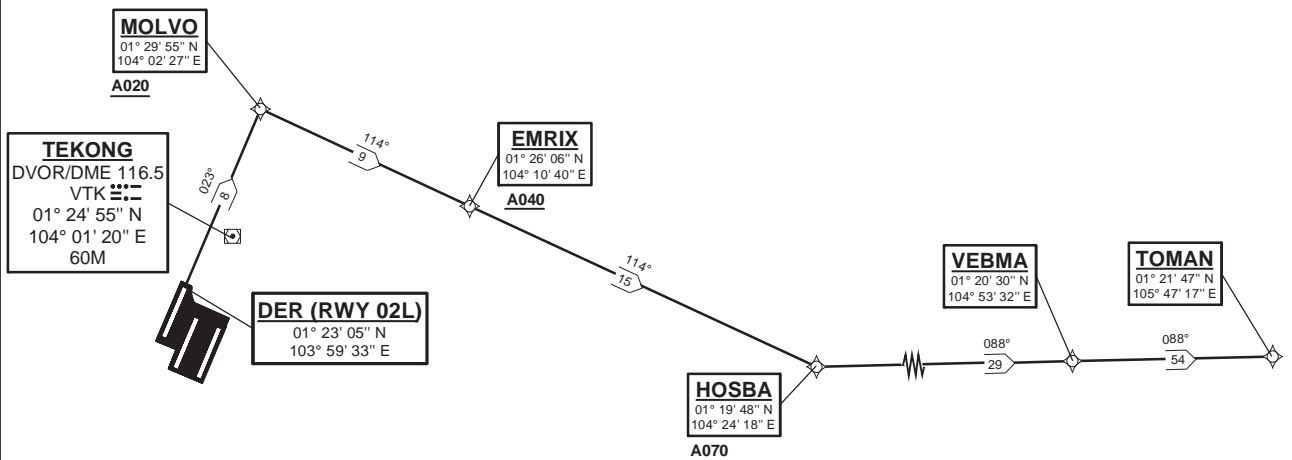
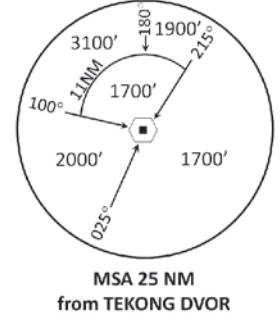

NOT TO SCALE

31 OCT 2024

TOMAN 3E (SID) RNAV GNSS RWY 02L - DESCRIPTIONS**Formal & Abbreviated Descriptions**

Formal Description	Abbreviated Description	Path Terminator	Fly-Over required
To MOLVO on course 023° at or above 2000ft, turn right.	MOLVO [M023; A020+; R] -	CF	N
To EMRIX at or above 4000ft.	EMRIX [A040+] -	TF	N
To HOSBA at or above 7000ft, turn left.	HOSBA [A070+; L] -	TF	N
To VEBMA.	VEBMA -	TF	N
To TOMAN.	TOMAN	TF	N

Tabular Descriptions

Path Term	Waypoint Name	Fly-Over	Course °M(°T)	Distance (NM)	Turn Direction	Altitude	Speed Limit	Navigation Spec
CF	MOLVO	-	023(023.4)	8.0	R	A020+	-	RNAV1
TF	EMRIX	-	114(114.4)	9.0	-	A040+	-	RNAV1
TF	HOSBA	-	114(114.4)	15.0	L	A070+	-	RNAV1
TF	VEBMA	-	088(088.4)	29.0	-	-	-	RNAV1
TF	TOMAN	-	088(088.4)	54.0	-	-	-	RNAV1

Radio Communications Failure Procedure

1	SET TRANSPONDER TO MODE A/C CODE 7600
2	COMMUNICATIONS FAILURE OCCURS IMMEDIATELY AFTER DEPARTURE: PROCEED DIRECT TO NYLON HOLDING AREA (NHA) CLIMBING TO THE LAST ASSIGNED ALTITUDE, THEREAFTER REFER TO SINGAPORE AIP ON RADIO COMMUNICATIONS FAILURE PROCEDURE.

STANDARD DEPARTURE CHART
RNAV (GNSS) -
INSTRUMENT (SID)

TWR 118.6 / 118.25
APP 120.3
124.05
ACC 134.2

TRANSITION ALTITUDE
11 000ft

D-ATIS AP ID-WSSS
128.6

SINGAPORE/Singapore Changi
RWY 20R
TOMAN DEPARTURES
TOMAN 5F

ELEV, ALT IN FEET
BEARINGS, TRACKS AND
RADIALS ARE MAGNETIC
VAR 0°23'E (2022)

DISTANCES IN NM

GENERAL INFORMATION

INITIAL CLIMB
3000FT

CAUTION: RWY 02R/20L NOT AVAILABLE FOR CIVIL USE UNTIL FURTHER ADVISED

NOTE: RADAR REQUIRED

NOTE: RNAV-1 NAVIGATION SPECIFICATION GNSS REQUIRED

NOTE: ACFT UNABLE TO FLY THE SID PROFILE
SHALL INFORM ATC PRIOR TO DEPARTURE AND
EXPECT RADAR VECTORED IF NECESSARY

NOTE: WHEN TAKEN OFF THE SID, AS INSTRUCTED BY ATC,
REFER TO ENR 1.5, SECTION 3, PARAGRAPH 3.4.2
- FOR RWY 20R MINIMUM CLIMB GRADIENT

NOTE: REFER TO BACK PAGE FOR
- FORMAL AND TABULAR DESCRIPTIONS
- RADIO COM FAILURE PROCEDURES

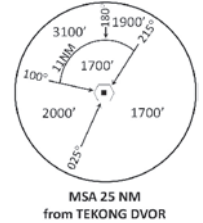

PROCEDURE INFORMATION

SID SHALL NOT EXCEED IAS 230KTS UNTIL
PASSING 4000FT AMSL AND NOT EXCEED
IAS 250KTS UNTIL PASSING 10000FT AMSL.

CRUISING LEVELS WILL BE ISSUED AFTER TAKE-OFF
BY SINGAPORE RADAR.

SID SHALL BE ON A MINIMUM CLIMB GRADIENT OF 6%
UNTIL REACHING OR PASSING 2500FT, THEREAFTER 3.3%.

GND SPEED - KNOTS	75	100	150	200	250	300
6% V/V (fpm)	456	608	911	1215	1518	1821
3.3% V/V (fpm)	251	334	501	668	835	1003

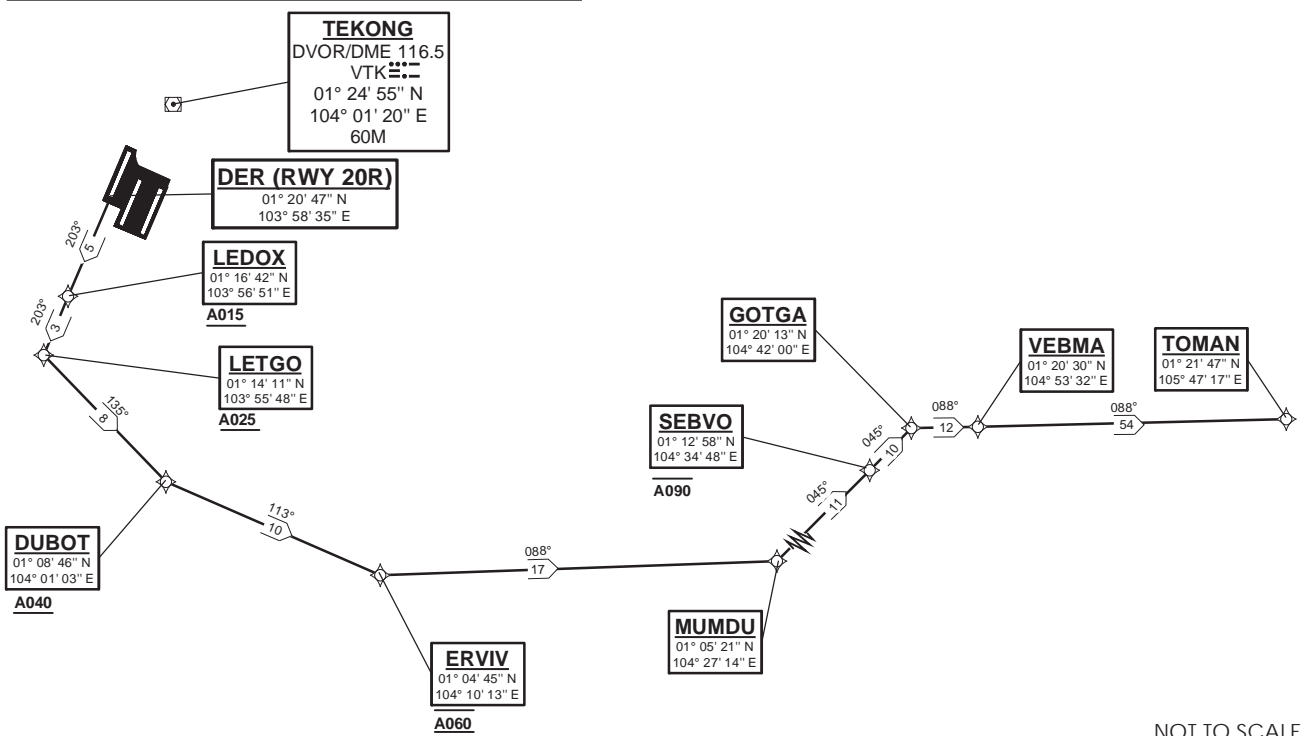

NOT TO SCALE

TOMAN 5F (SID) RNAV GNSS RWY 20R - DESCRIPTIONS

Formal & Abbreviated Descriptions

Formal Description	Abbreviated Description	Path Terminator	Fly-Over required
To LEDOX on course 203° at or above 1500ft.	LEDOX [M203; A015+] -	CF	N
To LETGO at or above 2500ft, turn left.	LETGO [A025+; L] -	TF	N
To DUBOT at or above 4000ft, turn left.	DUBOT [A040+; L] -	TF	N
To ERVIV at 6000ft, turn left.	ERVIV [@A060; L] -	TF	N
To MUMDU, turn left.	MUMDU [L] -	TF	N
To SEBVO at or below 9000ft.	SEBVO [A090-] -	TF	N
To GOTGA, turn right.	GOTGA [R] -	TF	N
To VEBMA.	VEBMA -	TF	N
To TOMAN.	TOMAN	TF	N

Tabular Descriptions

Path Term	Waypoint Name	Fly-Over	Course °M(°T)	Distance (NM)	Turn Direction	Altitude	Speed Limit	Navigation Spec
CF	LEDOX	-	203(203.4)	5.0	-	A015+	-	RNAV1
TF	LETGO	-	203(203.4)	3.0	L	A025+	-	RNAV1
TF	DUBOT	-	135(135.4)	8.0	L	A040+	-	RNAV1
TF	ERVIV	-	113(113.4)	10.0	L	@A060	-	RNAV1
TF	MUMDU	-	088(088.4)	17.0	L	-	-	RNAV1
TF	SEBVO	-	045(045.4)	11.0	-	A090-	-	RNAV1
TF	GOTGA	-	045(045.4)	10.0	R	-	-	RNAV1
TF	VEBMA	-	088(088.4)	12.0	-	-	-	RNAV1
TF	TOMAN	-	088(088.4)	54.0	-	-	-	RNAV1

Radio Communications Failure Procedure

1	SET TRANSPONDER TO MODE A/C CODE 7600
2	COMMUNICATIONS FAILURE OCCURS IMMEDIATELY AFTER DEPARTURE: PROCEED DIRECT TO SAMKO HOLDING AREA (SHA) CLIMBING TO THE LAST ASSIGNED ALTITUDE, THEREAFTER REFER TO SINGAPORE AIP ON RADIO COMMUNICATIONS FAILURE PROCEDURE.

STANDARD DEPARTURE CHART
RNAV (GNSS) -
INSTRUMENT (SID)

TWR 118.6 / 118.25
APP 120.3
124.05
ACC 133.25

TRANSITION ALTITUDE
11 000ft

D-ATIS AP ID-WSSS
128.6

SINGAPORE/Singapore Changi
RWY 20C
VOVOS DEPARTURES
VOVOS 1B

ELEV, ALT IN FEET

BEARINGS, TRACKS AND
RADIALS ARE MAGNETIC
VAR 0°23'E (2020)

DISTANCES IN NM

GENERAL INFORMATION

INITIAL CLIMB
3000FT

CAUTION: RWY 02R/20L NOT AVAILABLE FOR CIVIL USE UNTIL FURTHER ADVISED

NOTE: RADAR REQUIRED

NOTE: RNAV-1 NAVIGATION SPECIFICATION GNSS REQUIRED

NOTE: ACFT UNABLE TO FLY THE SID PROFILE
SHALL INFORM ATC PRIOR TO DEPARTURE AND
EXPECT RADAR VECTORING IF NECESSARY

NOTE: WHEN TAKEN OFF THE SID, AS INSTRUCTED BY ATC,
REFER TO ENR 1.5, SECTION 3, PARAGRAPH 3.4.1
- FOR RWY 20C MINIMUM CLIMB GRADIENT

NOTE: REFER TO BACK PAGE FOR
- FORMAL AND TABULAR DESCRIPTIONS
- RADIO COM FAILURE PROCEDURES

NOTE: VOVOS SID WILL NOT BE AVAILABLE FOR
FLIGHT PLANNING UNTIL FURTHER ADVISED

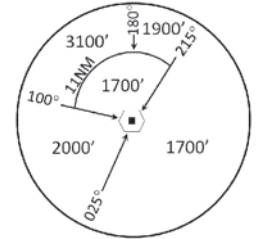

MSA 25 NM
from TEKONG DVOR

PROCEDURE INFORMATION

SID SHALL NOT EXCEED IAS 230KTS UNTIL
PASSING 4000FT AMSL AND NOT EXCEED
IAS 250KTS UNTIL PASSING 10000FT AMSL.

CRUISING LEVELS WILL BE ISSUED AFTER TAKE-OFF
BY SINGAPORE RADAR.

SID SHALL BE ON A MINIMUM CLIMB GRADIENT OF 7%
UNTIL REACHING OR PASSING 2500FT, THEREAFTER 3.3%.

GND SPEED - KNOTS	75	100	150	200	250	300
7% V/V (fpm)	532	709	1063	1418	1772	2127
3.3% V/V (fpm)	251	334	501	668	835	1003

TEKONG
DVOR/DME 116.5
VTK
01° 24' 55"N
104° 01' 20" E
60m

DER (RWY 20C)
01° 19' 42.00" N
103° 59' 05.00" E

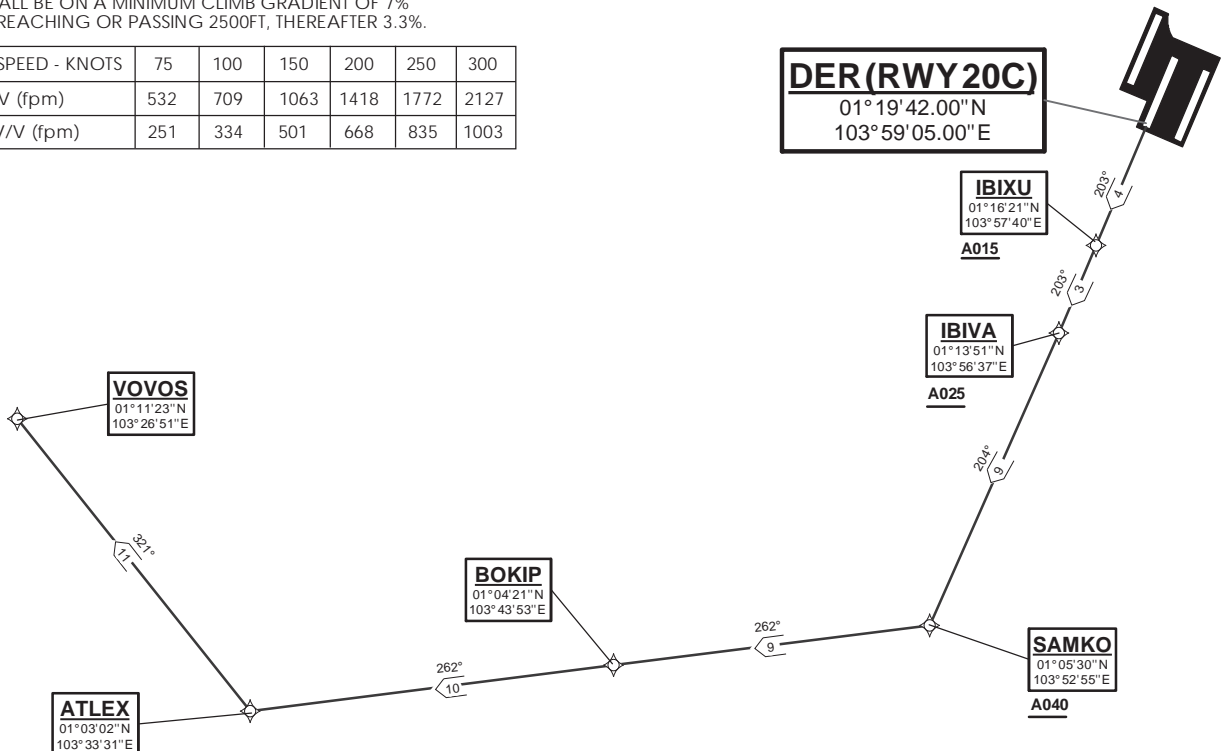

NOT TO SCALE

VOVOS 1B (SID) RNAV GNSS RWY 20C - DESCRIPTIONS**Formal & Abbreviated Descriptions**

Formal Description	Abbreviated Description	Path Terminator	Fly-Over required
To IBIXU on course 203° at or above 1500ft.	IBIXU [M203; A015+] -	CF	N
To IBIVA at or above 2500ft, turn right.	IBIVA [A025+; R] -	TF	N
To SAMKO at or above 4000ft, turn right.	SAMKO [A040+; R] -	TF	N
To BOKIP.	BOKIP -	TF	N
To ATLEX, turn right.	ATLEX [R] -	TF	N
To VOVOS.	VOVOS	TF	N

Tabular Descriptions

Path Term	Waypoint Name	Fly-Over	Course °M(°T)	Distance (NM)	Turn Direction	Altitude	Speed Limit	Navigation Spec
CF	IBIXU	-	203(203.4)	4.0	-	A015+	-	RNAV1
TF	IBIVA	-	203(203.4)	3.0	R	A025+	-	RNAV1
TF	SAMKO	-	204(204.4)	9.0	R	A040+	-	RNAV1
TF	BOKIP	-	262(262.4)	9.0	-	-	-	RNAV1
TF	ATLEX	-	262(262.4)	10.0	R	-	-	RNAV1
TF	VOVOS	-	321(321.4)	11.0	-	-	-	RNAV1

Radio Communications Failure Procedure

1	SET TRANSPONDER TO MODE A/C CODE 7600
2	COMMUNICATIONS FAILURE OCCURS IMMEDIATELY AFTER DEPARTURE: PROCEED DIRECT TO SAMKO HOLDING AREA (SHA) CLIMBING TO THE LAST ASSIGNED ALTITUDE, THEREAFTER REFER TO SINGAPORE AIP ON RADIO COMMUNICATIONS FAILURE PROCEDURE.

STANDARD DEPARTURE CHART
RNAV (GNSS) -
INSTRUMENT (SID)

TWR 118.6 / 118.25
APP 120.3
124.05
ACC 133.25

TRANSITION ALTITUDE
11 000ft

D-ATIS AP ID-WSSS
128.6

SINGAPORE/Singapore Changi
RWY 20L
VOVOS DEPARTURES
VOVOS 1D

ELEV, ALT IN FEET

BEARINGS, TRACKS AND
RADIALS ARE MAGNETIC
VAR 0°23'E (2020)

DISTANCES IN NM

GENERAL INFORMATION

INITIAL CLIMB
3000FT

CAUTION: RWY 02R/20L NOT AVAILABLE FOR CIVIL USE UNTIL FURTHER ADVISED

NOTE: RADAR REQUIRED

NOTE: RNAV-1 NAVIGATION SPECIFICATION GNSS REQUIRED

NOTE: ACFT UNABLE TO FLY THE SID PROFILE
SHALL INFORM ATC PRIOR TO DEPARTURE AND
EXPECT RADAR VECTORING IF NECESSARY

NOTE: WHEN TAKEN OFF THE SID, AS INSTRUCTED BY ATC,
REFER TO ENR 1.5, SECTION 3, PARAGRAPH 3.4.3
- FOR RWY 20L MINIMUM CLIMB GRADIENT

NOTE: REFER TO BACK PAGE FOR
- FORMAL AND TABULAR DESCRIPTIONS
- RADIO COM FAILURE PROCEDURES

NOTE: VOVOS SID WILL NOT BE AVAILABLE FOR
FLIGHT PLANNING UNTIL FURTHER ADVISED

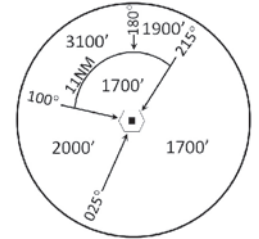

MSA 25 NM
from TEKONG DVOR

PROCEDURE INFORMATION

SID SHALL NOT EXCEED IAS 230KTS UNTIL
PASSING 4000FT AMSL AND NOT EXCEED
IAS 250KTS UNTIL PASSING 10000FT AMSL.

CRUISING LEVELS WILL BE ISSUED AFTER TAKE-OFF
BY SINGAPORE RADAR.

SID SHALL BE ON A MINIMUM CLIMB GRADIENT OF 9%
UNTIL REACHING OR PASSING 2500FT, THEREAFTER 3.3%.

GND SPEED - KNOTS	75	100	150	200	250	300
9% V/V (fpm)	684	911	1367	1823	2279	2734
3.3% V/V (fpm)	251	334	501	668	835	1003

TEKONG
DVOR/DME 116.5
VTK
01° 24' 55"N
104° 01' 20" E
60m

DER (RWY 20L)
01° 19' 19"N
103° 59' 59"E

UKIBO
01° 17' 58"N
103° 59' 24"E

VIGUD
01° 13' 28"N
103° 57' 30"E
A025

SAMKO
01° 05' 30"N
103° 52' 55"E
A040

VOVOS
01° 11' 23"N
103° 26' 51"E

ATLEX
01° 03' 02"N
103° 33' 31"E

BOKIP
01° 04' 21"N
103° 43' 53"E

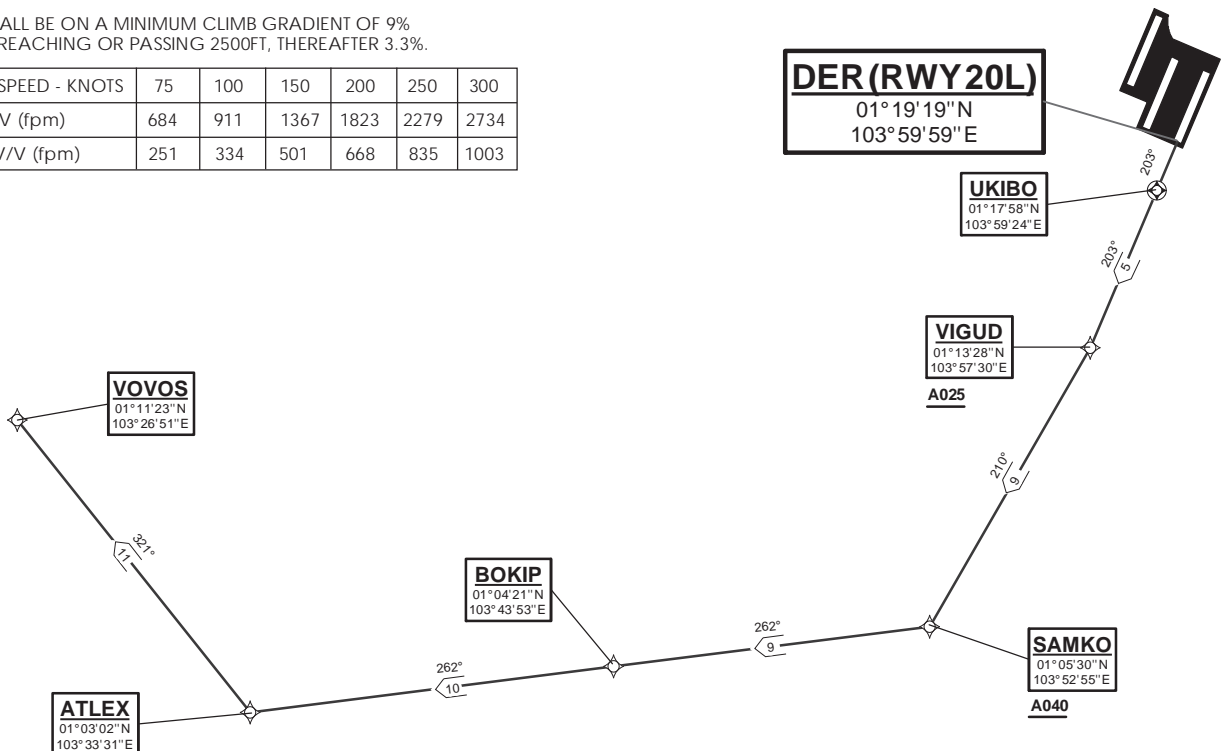

NOT TO SCALE

31 OCT 2024

VOVOS 1D (SID) RNAV GNSS RWY 20L - DESCRIPTIONS**Formal & Abbreviated Descriptions**

Formal Description	Abbreviated Description	Path Terminator	Fly-Over required
To UKIBO on course 203°.	UKIBO [M203] -	CF	N
To VIGUD at or above 2500ft, turn right.	VIGUD [A025+; R] -	TF	N
To SAMKO at or above 4000ft, turn right.	SAMKO [A040+; R] -	TF	N
To BOKIP.	BOKIP -	TF	N
To ATLEX, turn right.	ATLEX [R] -	TF	N
To VOVOS.	VOVOS	TF	N

Tabular Descriptions

Path Term	Waypoint Name	Fly-Over	Course °M(°T)	Distance (NM)	Turn Direction	Altitude	Speed Limit	Navigation Spec
CF	UKIBO	Y	203(203.4)	1.5	-	-	-	RNAV1
TF	VIGUD	-	203(203.4)	5.0	R	A025+	-	RNAV1
TF	SAMKO	-	210(210.4)	9.0	R	A040+	-	RNAV1
TF	BOKIP	-	262(262.4)	9.0	-	-	-	RNAV1
TF	ATLEX	-	262(262.4)	10.0	R	-	-	RNAV1
TF	VOVOS	-	321(321.4)	11.0	-	-	-	RNAV1

Radio Communications Failure Procedure

1	SET TRANSPONDER TO MODE A/C CODE 7600
2	COMMUNICATIONS FAILURE OCCURS IMMEDIATELY AFTER DEPARTURE: PROCEED DIRECT TO SAMKO HOLDING AREA (SHA) CLIMBING TO THE LAST ASSIGNED ALTITUDE, THEREAFTER REFER TO SINGAPORE AIP ON RADIO COMMUNICATIONS FAILURE PROCEDURE.

STANDARD DEPARTURE CHART
RNAV (GNSS) -
INSTRUMENT (SID)

TWR 118.6 / 118.25
APP 120.3
124.05
ACC 133.25

TRANSITION ALTITUDE
11 000ft

D-ATIS AP ID-WSSS
128.6

SINGAPORE/Singapore Changi
RWY 20R
VOVOS DEPARTURES
VOVOS 1F

ELEV, ALT IN FEET

BEARINGS, TRACKS AND
RADIALS ARE MAGNETIC
VAR 0°23'E (2020)

DISTANCES IN NM

GENERAL INFORMATION

INITIAL CLIMB
3000FT

CAUTION: RWY 02R/20L NOT AVAILABLE FOR CIVIL USE UNTIL FURTHER ADVISED

NOTE: RADAR REQUIRED

NOTE: RNAV-1 NAVIGATION SPECIFICATION GNSS REQUIRED

NOTE: ACFT UNABLE TO FLY THE SID PROFILE
SHALL INFORM ATC PRIOR TO DEPARTURE AND
EXPECT RADAR VECTORED IF NECESSARY

NOTE: WHEN TAKEN OFF THE SID, AS INSTRUCTED BY ATC,
REFER TO ENR 1.5, SECTION 3, PARAGRAPH 3.4.2
- FOR RWY 20R MINIMUM CLIMB GRADIENT

NOTE: REFER TO BACK PAGE FOR
- FORMAL AND TABULAR DESCRIPTIONS
- RADIO COM FAILURE PROCEDURES

NOTE: VOVOS SID WILL NOT BE AVAILABLE FOR
FLIGHT PLANNING UNTIL FURTHER ADVISED

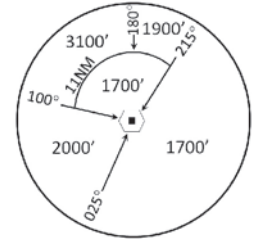

MSA 25 NM
from TEKONG DVOR

PROCEDURE INFORMATION

SID SHALL NOT EXCEED IAS 230KTS UNTIL
PASSING 4000FT AMSL AND NOT EXCEED
IAS 250KTS UNTIL PASSING 10000FT AMSL.

CRUISING LEVELS WILL BE ISSUED AFTER TAKE-OFF
BY SINGAPORE RADAR.

SID SHALL BE ON A MINIMUM CLIMB GRADIENT OF 6%
UNTIL REACHING OR PASSING 2500FT, THEREAFTER 3.3%.

GND SPEED - KNOTS	75	100	150	200	250	300
6% V/V (fpm)	456	608	911	1215	1518	1821
3.3% V/V (fpm)	251	334	501	668	835	1003

TEKONG
DVOR/DME 116.5
VTK
01° 24' 55"N
104° 01' 20" E
60m

DER (RWY 20R)
01° 20' 47.00"N
103° 58' 35.00"E

LEDOX
01° 16' 42"N
103° 56' 51"E
A015

LETGO
01° 14' 11"N
103° 55' 48"E
A025

BOKIP
01° 04' 21"N
103° 43' 53"E

SAMKO
01° 05' 30"N
103° 52' 55"E
A040

ATLEX
01° 03' 02"N
103° 33' 31"E

VOVOS
01° 11' 23"N
103° 26' 51"E

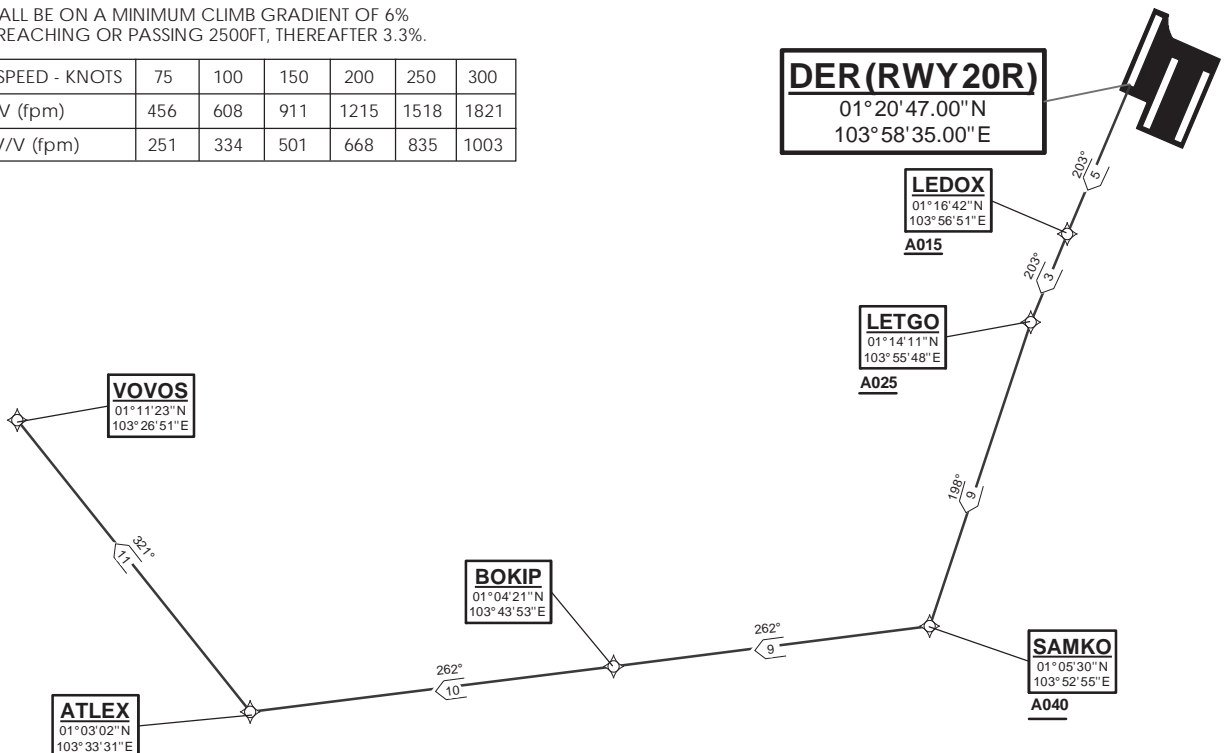

NOT TO SCALE

VOVOS 1F (SID) RNAV GNSS RWY 20R - DESCRIPTIONS**Formal & Abbreviated Descriptions**

Formal Description	Abbreviated Description	Path Terminator	Fly-Over required
To LEDOX on course 203° at or above 1500ft.	LEDOX [M203; A015+] -	CF	N
To LETGO at or above 2500ft, turn left.	LETGO [A025+; L] -	TF	N
To SAMKO at or above 4000ft, turn right.	SAMKO [A040+; R] -	TF	N
To BOKIP.	BOKIP -	TF	N
To ATLEX, turn right.	ATLEX [R] -	TF	N
To VOVOS.	VOVOS	TF	N

Tabular Descriptions

Path Term	Waypoint Name	Fly-Over	Course °M(°T)	Distance (NM)	Turn Direction	Altitude	Speed Limit	Navigation Spec
CF	LEDOX	-	203(203.4)	5.0	-	A015+	-	RNAV1
TF	LETGO	-	203(203.4)	3.0	L	A025+	-	RNAV1
TF	SAMKO	-	198(198.4)	9.0	R	A040+	-	RNAV1
TF	BOKIP	-	262(262.4)	9.0	-	-	-	RNAV1
TF	ATLEX	-	262(262.4)	10.0	R	-	-	RNAV1
TF	VOVOS	-	321(321.4)	11.0	-	-	-	RNAV1

Radio Communications Failure Procedure

1	SET TRANSPONDER TO MODE A/C CODE 7600
2	COMMUNICATIONS FAILURE OCCURS IMMEDIATELY AFTER DEPARTURE: PROCEED DIRECT TO SAMKO HOLDING AREA (SHA) CLIMBING TO THE LAST ASSIGNED ALTITUDE, THEREAFTER REFER TO SINGAPORE AIP ON RADIO COMMUNICATIONS FAILURE PROCEDURE.

**STANDARD INSTRUMENT
DEPARTURES (SID)
CHART**

TWR	131.4
APP	120.3
ACC	133.8/134.4/133.25/ 134.2

TRANSITION ALTITUDE
11 000ft

D-ATIS AP ID-WSSS
128.6

**SINGAPORE/Singapore Changi
RWY 02R/20L
CHANGI DEPARTURE (RADAR)
CHA 1C (R02R)
CHA 1D (R20L)**

ELEV, ALT IN FEET

BEARINGS, TRACKS AND
RADIALS ARE MAGNETIC
VAR 0°23'E (2020)

DISTANCES IN NM

**CAUTION: RWY 02R/20L NOT AVAILABLE FOR CIVIL USE UNTIL
FURTHER ADVISED**

NOTE: RADAR REQUIRED

NOTE: ACFT UNABLE TO COMPLY WITH CLIMB GRADIENT
RESTRICTION SHALL INFORM ATC DURING THE TIME
ACFT COMMENCES TAXIING TO HOLDING POINT FOR
DEPARTURE

NOTE: REFER TO BACK PAGE FOR
- FORMAL AND TABULAR DESCRIPTIONS
- RADIO COM FAILURE PROCEDURES

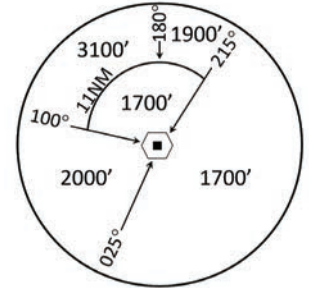

**MSA 25 NM
from TEKONG DVOR**

GENERAL INFORMATION

**INITIAL CLIMB
3000FT**

ACFT ON DEPARTURE SHALL NOT EXCEED IAS 230KTS
UNTIL PASSING 4000FT AMSL AND NOT EXCEED IAS 250KTS
UNTIL PASSING 10000FT AMSL.

CRUISING LEVELS WILL BE ISSUED AFTER TAKE-OFF
BY SINGAPORE RADAR.

ACFT ON DEPARTURE **02R** SHALL BE ON A MINIMUM CLIMB GRADIENT
OF 5% UNTIL REACHING OR PASSING 2500FT, THEREAFTER 3.3%.

GND SPEED - KNOTS	75	100	150	200	250	300
5% V/V (fpm)	380	506	760	1013	1266	1519
3.3% V/V (fpm)	251	334	501	668	835	1003

ACFT ON DEPARTURE **20L** SHALL BE ON A MINIMUM CLIMB GRADIENT
OF 9% UNTIL REACHING OR PASSING 2500FT, THEREAFTER 3.3%.

GND SPEED - KNOTS	75	100	150	200	250	300
9% V/V (fpm)	684	911	1367	1823	2279	2734
3.3% V/V (fpm)	251	334	501	668	835	1003

TEKONG
DVOR/DME 116.5
VTK
01° 24' 55"N
104° 01' 20" E
60m

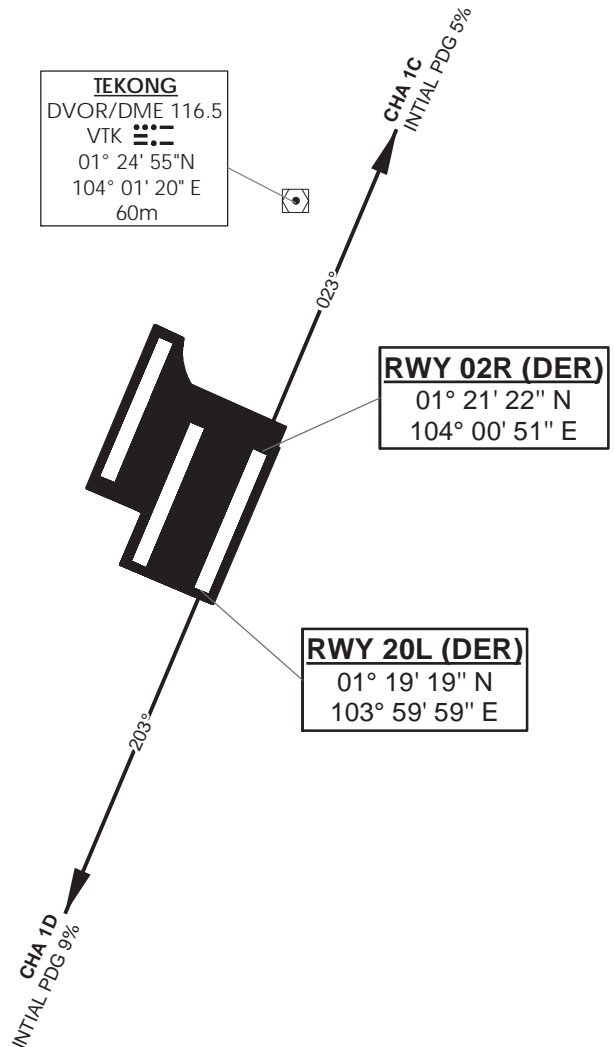

NOT TO SCALE

31 OCT 2024

CHA 1C SID (RADAR) RWY 02R - DESCRIPTIONS**Formal & Abbreviated Descriptions**

Formal Description	Abbreviated Description	Path Terminator
Climb heading 023°, Gradient 5% to 2500ft, thence 3.3%. Expect radar vectors to the planned ATS route or waypoints listed in table A.	-	VA

Tabular Descriptions

Path Terminator	Turn Direction	Course °M (°T)	Altitude	Speed Limit
VA	-	023 (023.4)	A030	-

CHA 1D SID (RADAR) RWY 20L - DESCRIPTIONS**Formal & Abbreviated Descriptions**

Formal Description	Abbreviated Description	Path Terminator
Climb heading 203°, Gradient 9% to 2500ft, thence 3.3%. Expect radar vectors to the planned ATS route or waypoints listed in table A.	-	VA

Tabular Descriptions

Path Terminator	Turn Direction	Course °M (°T)	Altitude	Speed Limit
VA	-	203 (203.4)	A030	-

Table A

Planned ATS Routes	Expect Radar Vectors to the waypoints listed below and thereafter to join the respective planned ATS Route
A457	AKOMA DCT SABKA DCT MASBO
B470	VIRET DCT ANITO
G580 / M646 / L625 / T21 - L504 / T21 - M774	VEBMA DCT TOMAN
L762	VIBOG DCT BISOV DCT MIBEL
B469 / M751 / M771 / L642 / M753	AKOMA DCT VMR
T24 - M635	VIRET DCT GURES DCT IDBUD
W26	VIRET DCT GURES DCT IKIRO DCT KIRDA
R469	VIBOG DCT TAROS
Y513	AKOMA DCT AKMET DCT AROSO

RADIO COMMUNICATIONS FAILURE PROCEDURE

1	SET TRANSPONDER TO MODE A/C CODE 7600
2	COMMUNICATIONS FAILURE OCCURS IMMEDIATELY AFTER DEPARTURE ON: RWY 02R - PROCEED DIRECT TO NYLON HOLDING AREA (NHA) CLIMBING TO THE LAST ASSIGNED ALTITUDE, THEREAFTER REFER TO SINGAPORE AIP ON RADIO COMMUNICATIONS FAILURE PROCEDURE. RWY 20L - PROCEED DIRECT TO SAMKO HOLDING AREA (SHA) CLIMBING TO THE LAST ASSIGNED ALTITUDE, THEREAFTER REFER TO SINGAPORE AIP ON RADIO COMMUNICATIONS FAILURE PROCEDURE.

**STANDARD ARRIVAL CHART
RNAV (GNSS) -
INSTRUMENT (STAR)**

ACC 133.25
APP 124.6
119.3
TWR 118.6 / 118.25

TRANSITION ALTITUDE
11 000ft

D-ATIS AP ID-WSSS
ARR 128.025

**SINGAPORE/Singapore Changi
RWY 02L/C/R
ARAMA ONE ALPHA ARRIVAL
ARAMA 1A**

ELEV, ALT IN FEET
BEARINGS, TRACKS AND
RADIALS ARE MAGNETIC
VAR 0°23'E (2020)

DISTANCES IN NM

**CAUTION: RWY 02R/20L NOT AVAILABLE FOR CIVIL USE UNTIL
FURTHER ADVISED**

NOTE: RADAR REQUIRED

NOTE: RNAV-1 NAVIGATION SPECIFICATION GNSS REQUIRED

NOTE: REFER TO BACK PAGE FOR
- FORMAL AND TABULAR DESCRIPTIONS
- RADIO COM FAILURE PROCEDURES

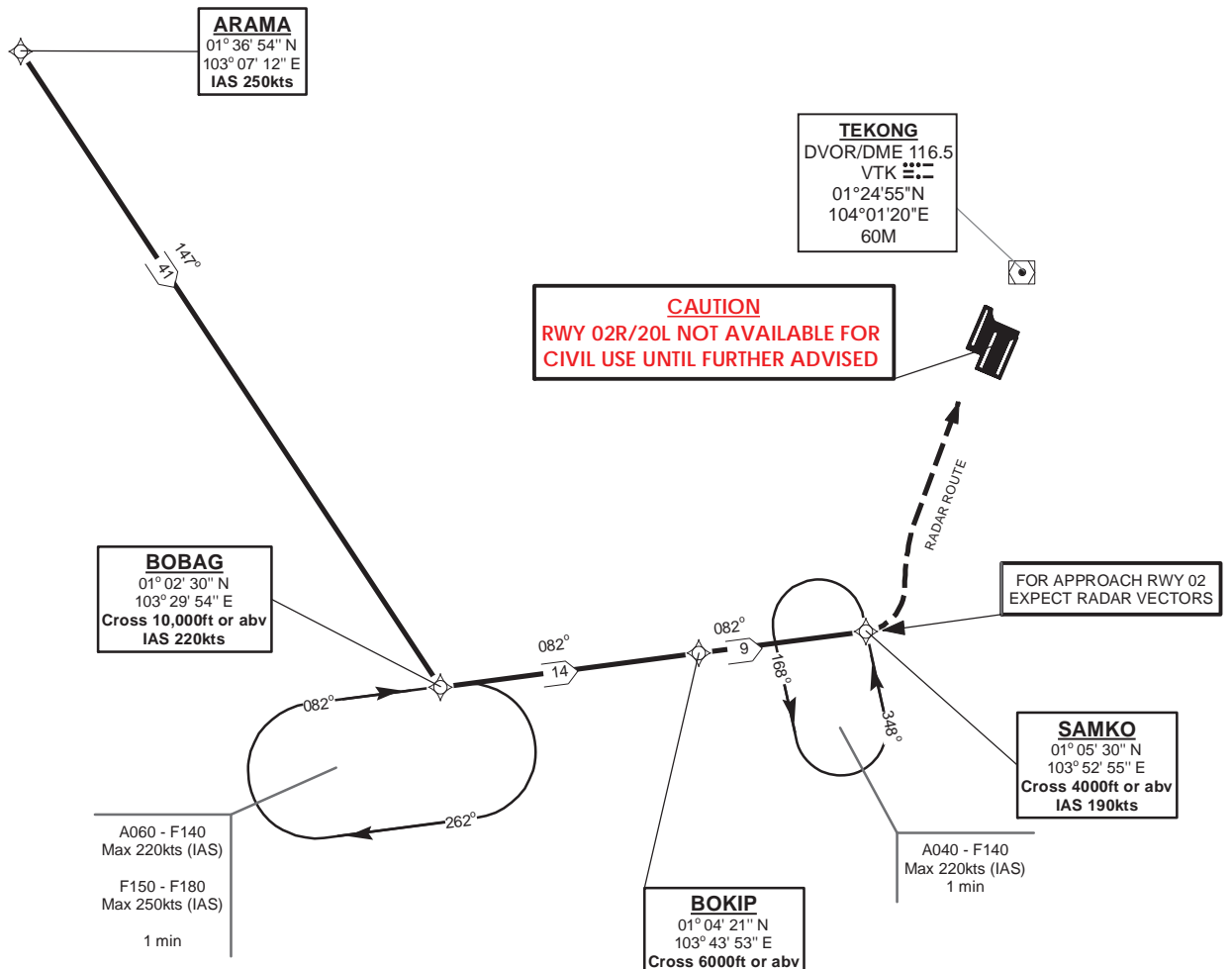
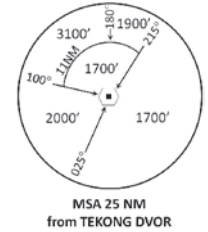

NOT TO SCALE

31 OCT 2024

ARAMA 1A (STAR) RNAV GNSS RWY 02L/02C/02R - DESCRIPTIONS**Formal & Abbreviated Descriptions**

Formal Description	Abbreviated Description	Path Terminator	Fly-Over required
From ARAMA, speed 250kts.	ARAMA [K250] -	IF	N
To BOBAG at or above 10000ft, speed 220kts, turn left.	BOBAG [A100+; K220; L] -	TF	N
To BOKIP at or above 6000ft.	BOKIP [A060+] -	TF	N
To SAMKO at or above 4000ft, speed 190kts.	SAMKO [A040+; K190]	TF	N

Tabular Descriptions

Path Term	Waypoint Name	Fly-Over	Course °M(°T)	Distance (NM)	Turn Direction	Altitude	Speed Limit	Navigation Spec
IF	ARAMA	-	-	-	-	-	K250	RNAV1
TF	BOBAG	-	147(147.4)	41.0	L	A100+	K220	RNAV1
TF	BOKIP	-	082(082.4)	14.0	-	A060+	-	RNAV1
TF	SAMKO	-	082(082.4)	9.0	-	A040+	K190	RNAV1

Radio Communications Failure Procedure

1	SET TRANSPONDER TO MODE A/C CODE 7600
2	<p>When cleared via ARAMA 1A by Singapore ATC</p> <p>(a) Maintain last assigned flight level or altitude and proceed on ARAMA 1A to SAMKO</p> <p>(b) From SAMKO commence descent and carry out appropriate landing procedure for RWY 02 as close as possible to EAT or ETA</p> <p>(c) If unable to effect a landing, refer to Singapore AIP for missed approach procedure</p>
3	<p>No clearance or instruction received from Singapore ATC</p> <p>- Refer to Singapore AIP for radio communications failure procedure</p>

STANDARD ARRIVAL CHART
RNAV (GNSS) -
INSTRUMENT (STAR)

ACC 133.25
APP 124.6
119.3
TWR 118.6 / 118.25

TRANSITION ALTITUDE
11 000ft

D-ATIS AP ID-WSSS
128.025

SINGAPORE/Singapore Changi
RWY 20R/C/L
ARAMA ONE BRAVO ARRIVAL
ARAMA 1B

ELEV, ALT IN FEET
BEARINGS, TRACKS AND
RADIALS ARE MAGNETIC
VAR 0°23'E (2020)

DISTANCES IN NM

CAUTION: RWY 02R/20L NOT AVAILABLE FOR CIVIL USE UNTIL FURTHER ADVISED

NOTE: RADAR REQUIRED

NOTE: RNAV-1 NAVIGATION SPECIFICATION GNSS REQUIRED

NOTE: REFER TO BACK PAGE FOR
- FORMAL AND TABULAR DESCRIPTIONS
- RADIO COM FAILURE PROCEDURES

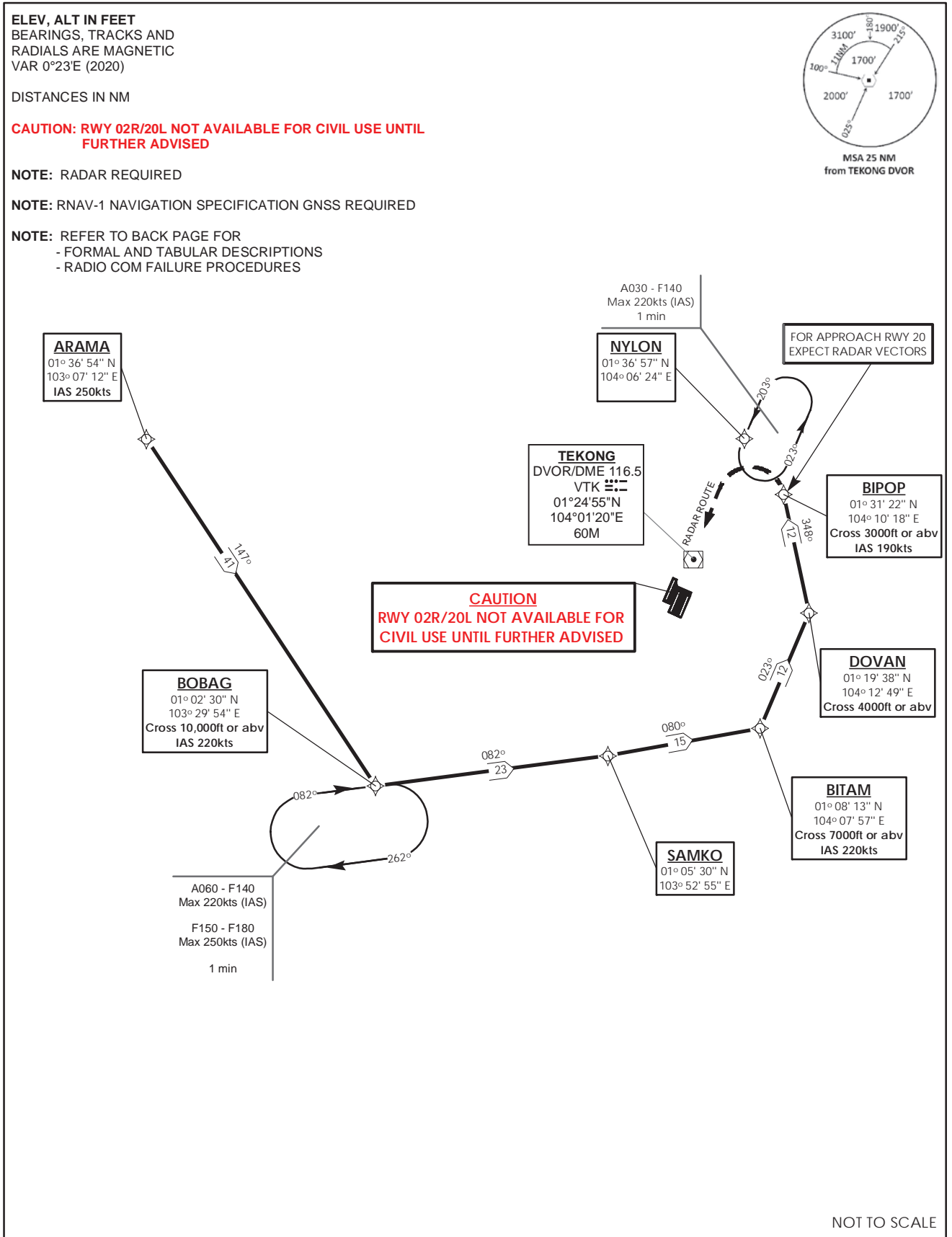
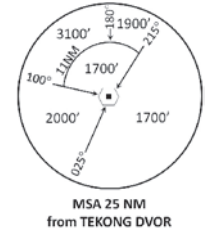

31 OCT 2024

ARAMA 1B (STAR) RNAV GNSS RWY 20R/20C/20L - DESCRIPTIONS**Formal & Abbreviated Descriptions**

Formal Description	Abbreviated Description	Path Terminator	Fly-Over required
From ARAMA, speed 250kts.	ARAMA [K250] -	IF	N
To BOBAG at or above 10000ft, speed 220kts, turn left.	BOBAG [A100+; K220; L] -	TF	N
To SAMKO, turn left.	SAMKO [L] -	TF	N
To BITAM at or above 7000ft, speed 220kts, turn left.	BITAM [A070+; K220; L] -	TF	N
To DOVAN at or above 4000ft, turn left.	DOVAN [A040+; L] -	TF	N
To BIPOP at or above 3000ft, speed 190kts.	BIPOP [A030+; K190]	TF	N

Tabular Descriptions

Path Term	Waypoint Name	Fly-Over	Course °M(°T)	Distance (NM)	Turn Direction	Altitude	Speed Limit	Navigation Spec
IF	ARAMA	-	-	-	-	-	K250	RNAV1
TF	BOBAG	-	147(147.4)	41.0	L	A100+	K220	RNAV1
TF	SAMKO	-	082(082.4)	23.0	L	-	-	RNAV1
TF	BITAM	-	080(080.4)	15.0	L	A070+	K220	RNAV1
TF	DOVAN	-	023(023.4)	12.0	L	A040+	-	RNAV1
TF	BIPOP	-	348(348.4)	12.0	-	A030+	K190	RNAV1

Radio Communications Failure Procedure

1	SET TRANSPONDER TO MODE A/C CODE 7600
2	<p>When cleared via ARAMA 1B by Singapore ATC</p> <p>(a) Maintain last assigned flight level or altitude and proceed on ARAMA 1B to BIPOP, then direct to NYLON</p> <p>(b) From NYLON commence descent and carry out appropriate landing procedure for RWY 20 as close as possible to EAT or ETA</p> <p>(c) If unable to effect a landing, refer to Singapore AIP for missed approach procedure</p>
3	<p>No clearance or instruction received from Singapore ATC</p> <p>- Refer to Singapore AIP for radio communications failure procedure</p>

**STANDARD ARRIVAL CHART
RNAV (GNSS) -
INSTRUMENT (STAR)**

ACC 133.25
APP 124.6
119.3
TWR 118.6 / 118.25

TRANSITION ALTITUDE
11 000ft

D-ATIS AP ID-WSSS
ARR 128.025

**SINGAPORE/Singapore Changi
RWY 02L/C/R
ASUNA TWO ALPHA ARRIVAL
ASUNA 2A**

ELEV, ALT IN FEET
BEARINGS, TRACKS AND
RADIALS ARE MAGNETIC
VAR 0°23'E (2020)

DISTANCES IN NM

**CAUTION: RWY 02R/20L NOT AVAILABLE FOR CIVIL USE UNTIL
FURTHER ADVISED**

NOTE: RADAR REQUIRED

NOTE: RNAV-1 NAVIGATION SPECIFICATION GNSS REQUIRED

NOTE: REFER TO BACK PAGE FOR
- FORMAL AND TABULAR DESCRIPTIONS
- RADIO COM FAILURE PROCEDURES

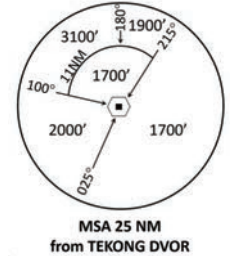

**CAUTION
RWY 02R/20L NOT AVAILABLE FOR
CIVIL USE UNTIL FURTHER ADVISED**

TEKONG
DVOR/DME 116.5
VTK
01° 24' 55" N
104° 01' 20" E
60m

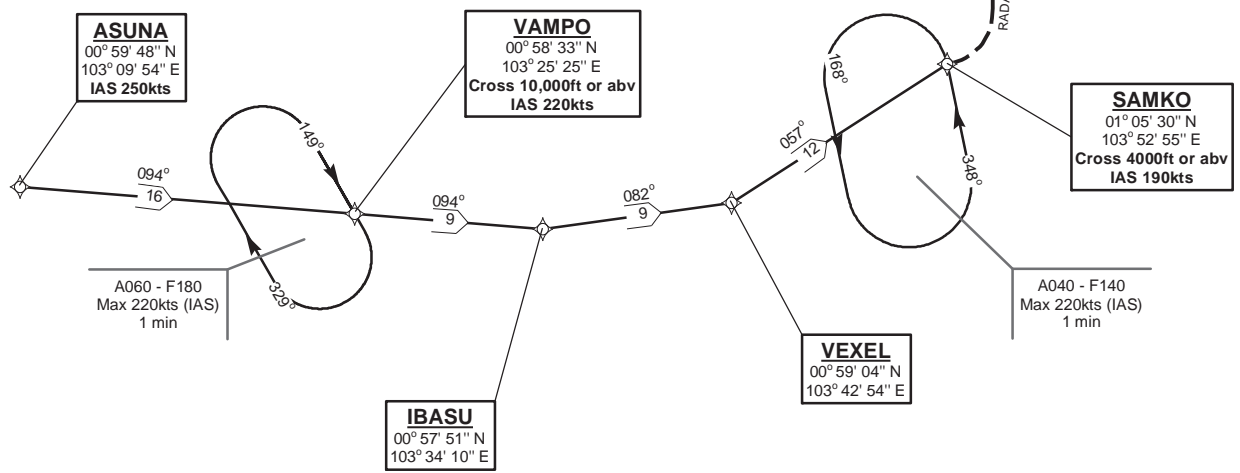

NOT TO SCALE

31 OCT 2024

ASUNA 2A (STAR) RNAV GNSS RWY 02L/02C/02R - DESCRIPTIONS**Formal & Abbreviated Descriptions**

Formal Description	Abbreviated Description	Path Terminator	Fly-Over required
From ASUNA, speed 250kts.	ASUNA [K250] -	IF	N
To VAMPO at or above 10000ft, speed 220kts.	VAMPO [A100+; K220] -	TF	N
To IBASU, turn left.	IBASU [L] -	TF	N
To VEXEL, turn left.	VEXEL [L] -	TF	N
To SAMKO at or above 4000ft, speed 190kts.	SAMKO [A040+; K190]	TF	N

Tabular Descriptions

Path Term	Waypoint Name	Fly-Over	Course °M(°T)	Distance (NM)	Turn Direction	Altitude	Speed Limit	Navigation Spec
IF	ASUNA	-	-	-	-	-	K250	RNAV1
TF	VAMPO	-	094(094.4)	16.0	-	A100+	K220	RNAV1
TF	IBASU	-	094(094.4)	9.0	L	-	-	RNAV1
TF	VEXEL	-	082(082.4)	9.0	L	-	-	RNAV1
TF	SAMKO	-	057(057.4)	12.0	-	A040+	K190	RNAV1

Radio Communications Failure Procedure

1	SET TRANSPONDER TO MODE A/C CODE 7600
2	<p>When cleared via ASUNA 2A by Singapore ATC</p> <p>(a) Maintain last assigned flight level or altitude and proceed on ASUNA 2A to SAMKO</p> <p>(b) From SAMKO commence descent and carry out appropriate landing procedure for RWY 02 as close as possible to EAT or ETA</p> <p>(c) If unable to effect a landing, refer to Singapore AIP for missed approach procedure</p>
3	<p>No clearance or instruction received from Singapore ATC</p> <p>- Refer to Singapore AIP for radio communications failure procedure</p>

**STANDARD ARRIVAL CHART
RNAV (GNSS) -
INSTRUMENT (STAR)**

ACC 133.25
APP 124.6
119.3
TWR 118.6 / 118.25

TRANSITION ALTITUDE
11 000ft

D-ATIS AP ID-WSSS
ARR 128.025

**SINGAPORE/Singapore Changi
RWY 20R/C/L
ASUNA TWO BRAVO ARRIVAL
ASUNA 2B**

ELEV, ALT IN FEET
BEARINGS, TRACKS AND
RADIALS ARE MAGNETIC
VAR 0°23'E (2020)

DISTANCES IN NM

**CAUTION: RWY 02R/20L NOT AVAILABLE FOR CIVIL USE UNTIL
FURTHER ADVISED**

NOTE: RADAR REQUIRED

NOTE: RNAV-1 NAVIGATION SPECIFICATION GNSS REQUIRED

NOTE: REFER TO BACK PAGE FOR
- FORMAL AND TABULAR DESCRIPTIONS
- RADIO COM FAILURE PROCEDURES

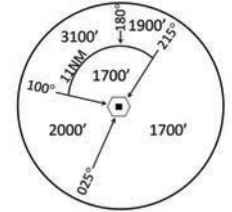

MSA 25 NM
from TEKONG DVOR

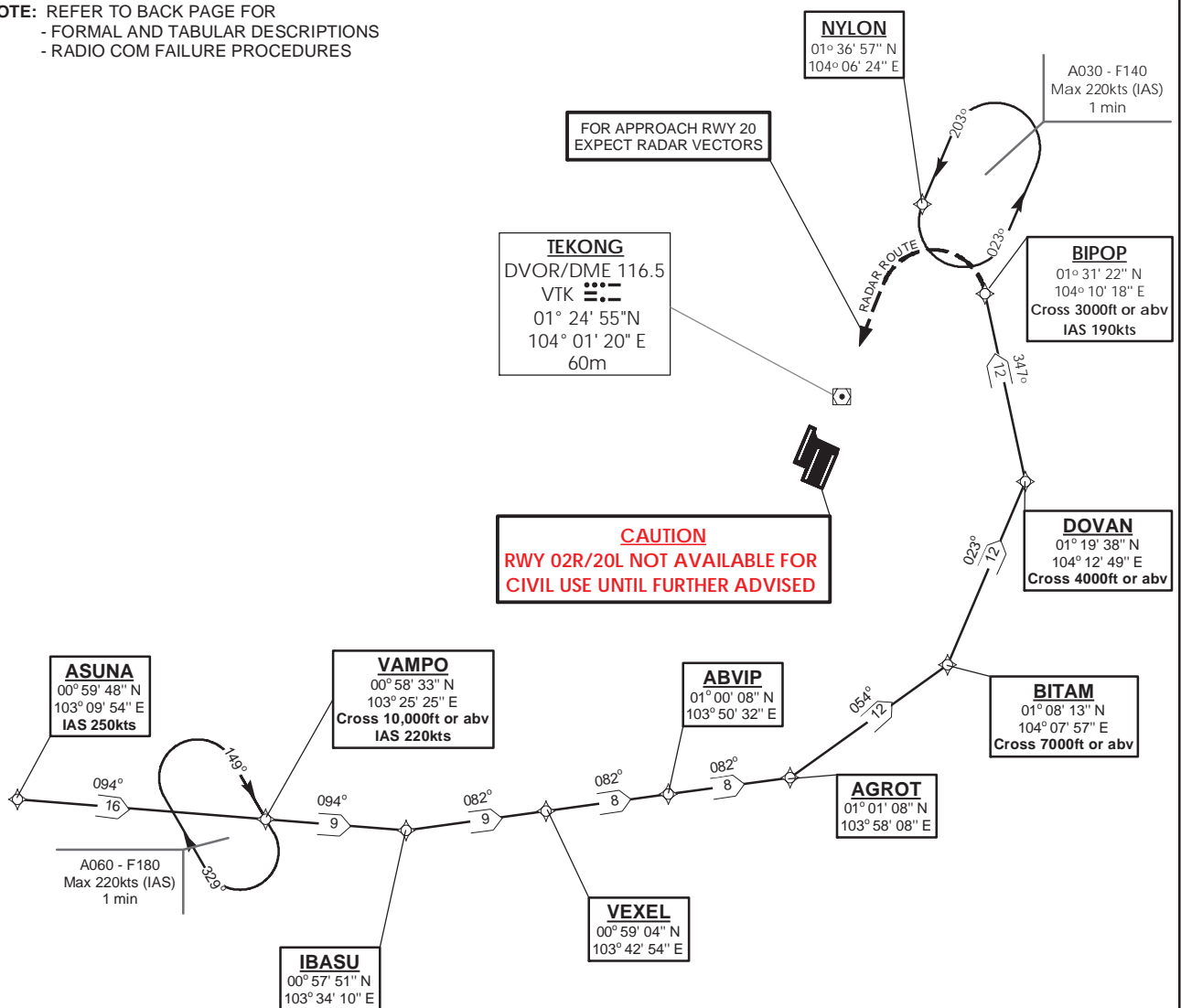

NOT TO SCALE

31 OCT 2024

ASUNA 2B (STAR) RNAV GNSS RWY 20R/20C/20L - DESCRIPTIONS**Formal & Abbreviated Descriptions**

Formal Description	Abbreviated Description	Path Terminator	Fly-Over required
From ASUNA, speed 250kts.	ASUNA [K250] -	IF	N
To VAMPO at or above 10000ft, speed 220kts.	VAMPO [A100+; K220] -	TF	N
To IBASU, turn left.	IBASU [L] -	TF	N
To VEXEL.	VEXEL -	TF	N
To ABVIP.	ABVIP -	TF	N
To AGROT, turn left.	AGROT [L] -	TF	N
To BITAM at or above 7000ft, turn left.	BITAM [A070+; L] -	TF	N
To DOVAN at or above 4000ft, turn left.	DOVAN [A040+; L] -	TF	N
To BIPOP at or above 3000ft, speed 190kts.	BIPOP [A030+; K190]	TF	N

Tabular Descriptions

Path Term	Waypoint Name	Fly-Over	Course °M(°T)	Distance (NM)	Turn Direction	Altitude	Speed Limit	Navigation Spec
IF	ASUNA	-	-	-	-	-	K250	RNAV1
TF	VAMPO	-	094(094.4)	16.0	-	A100+	K220	RNAV1
TF	IBASU	-	094(094.4)	9.0	L	-	-	RNAV1
TF	VEXEL	-	082(082.4)	9.0	-	-	-	RNAV1
TF	ABVIP	-	082(082.4)	8.0	-	-	-	RNAV1
TF	AGROT	-	082(082.4)	8.0	L	-	-	RNAV1
TF	BITAM	-	054(054.4)	12.0	L	A070+	-	RNAV1
TF	DOVAN	-	023(023.4)	12.0	L	A040+	-	RNAV1
TF	BIPOP	-	347(347.4)	12.0	-	A030+	K190	RNAV1

Radio Communications Failure Procedure

1	SET TRANSPONDER TO MODE A/C CODE 7600
2	<p>When cleared via ASUNA 2B by Singapore ATC</p> <p>(a) Maintain last assigned flight level or altitude and proceed on ASUNA 2B to BIPOP, then direct to NYLON</p> <p>(b) From NYLON commence descent and carry out appropriate landing procedure for RWY 20 as close as possible to EAT or ETA</p> <p>(c) If unable to effect a landing, refer to Singapore AIP for missed approach procedure</p>
3	<p>No clearance or instruction received from Singapore ATC</p> <p>- Refer to Singapore AIP for radio communications failure procedure</p>

STANDARD ARRIVAL CHART
RNAV (GNSS) -
INSTRUMENT (STAR)

ACC 133.8
APP 124.05
119.3
TWR 118.6 / 118.25

TRANSITION ALTITUDE 11 000ft
D-ATIS AP ID-WSSS 128.025

SINGAPORE/Singapore Changi
RWY 02L/C/R
ELALO ONE ALPHA ARRIVAL
ELALO 1A

ELEV, ALT IN FEET
BEARINGS, TRACKS AND
RADIALS ARE MAGNETIC
VAR 0°23'E (2020)

DISTANCES IN NM

CAUTION: RWY 02R/20L NOT AVAILABLE FOR CIVIL USE UNTIL FURTHER ADVISED

NOTE: RADAR REQUIRED

NOTE: RNAV-1 NAVIGATION SPECIFICATION GNSS REQUIRED

NOTE: REFER TO BACK PAGE FOR
- FORMAL AND TABULAR DESCRIPTIONS
- RADIO COM FAILURE PROCEDURES

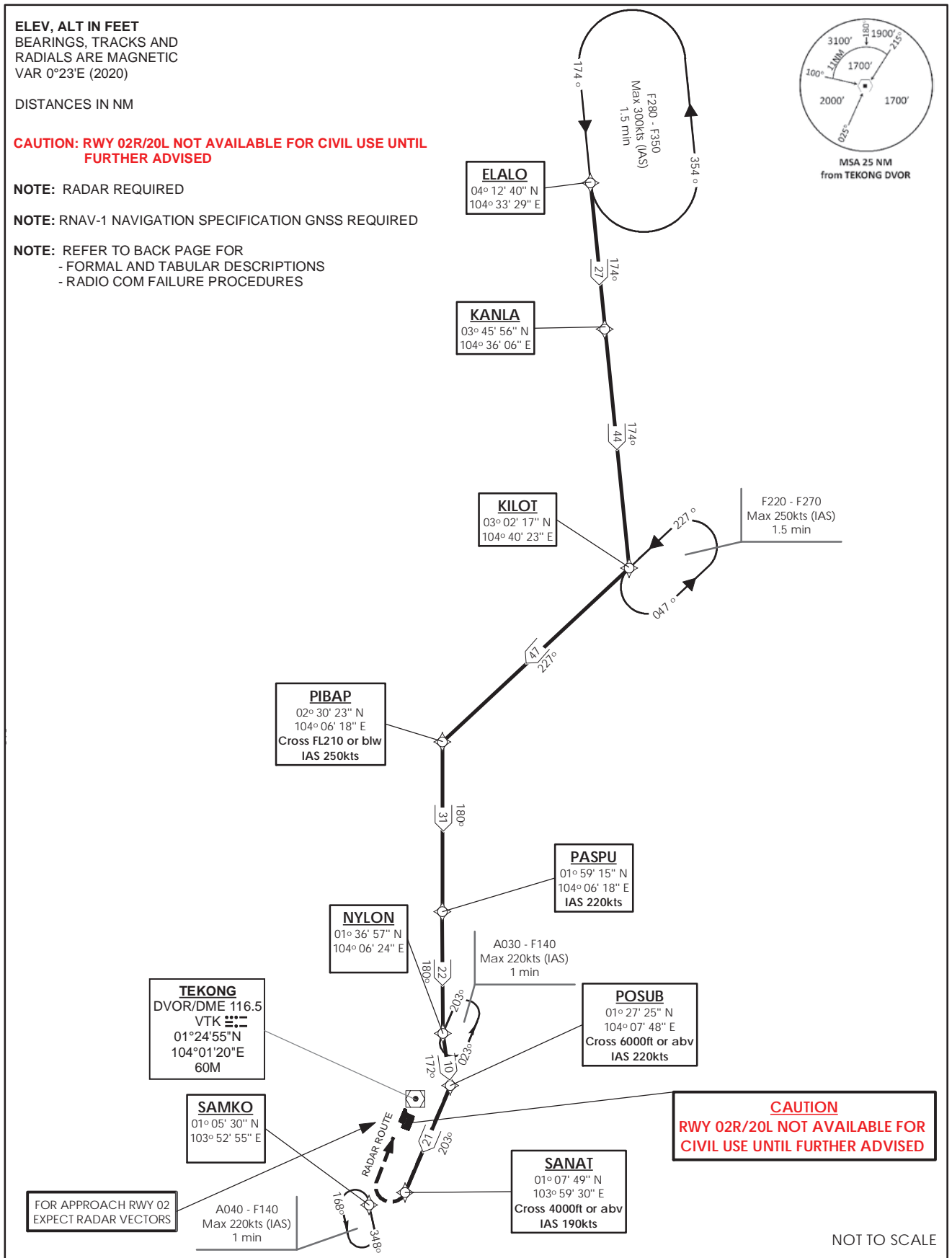
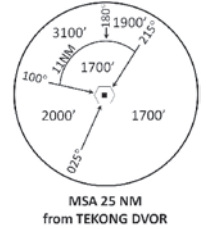

31 OCT 2024

ELALO 1A (STAR) RNAV GNSS RWY 02L/02C/02R - DESCRIPTIONS**Formal & Abbreviated Descriptions**

Formal Description	Abbreviated Description	Path Terminator	Fly-Over required
From ELALO.	ELALO -	IF	N
To KANLA.	KANLA -	TF	N
To KILOT, turn right.	KILOT [R] -	TF	N
To PIBAP at or below FL210, speed 250kts, turn left.	PIBAP [FL210-; K250; L] -	TF	N
To PASPU, speed 220kts.	PASPU [K220] -	TF	N
To NYLON, turn left.	NYLON [L] -	TF	N
To POSUB at or above 6000ft, speed 220kts, turn right.	POSUB [A060+; K220; R] -	TF	N
To SANAT at or above 4000ft, speed 190kts.	SANAT [A040+; K190]	TF	N

Tabular Descriptions

Path Term	Waypoint Name	Fly-Over	Course °M(°T)	Distance (NM)	Turn Direction	Altitude	Speed Limit	Navigation Spec
IF	ELALO	-	-	-	-	-	-	RNAV1
TF	KANLA	-	174(174.4)	27.0	-	-	-	RNAV1
TF	KILOT	-	174(174.4)	44.0	R	-	-	RNAV1
TF	PIBAP	-	227(227.4)	47.0	L	FL210-	K250	RNAV1
TF	PASPU	-	180(180.4)	31.0	-	-	K220	RNAV1
TF	NYLON	-	180(180.4)	22.0	L	-	-	RNAV1
TF	POSUB	-	172(172.4)	10.0	R	A060+	K220	RNAV1
TF	SANAT	-	203(203.4)	21.0	-	A040+	K190	RNAV1

Radio Communications Failure Procedure

1	SET TRANSPONDER TO MODE A/C CODE 7600
2	<p>When cleared via ELALO 1A by Singapore ATC</p> <p>(a) Maintain last assigned flight level or altitude and proceed on ELALO 1A to SANAT, then direct to SAMKO</p> <p>(b) From SAMKO commence descent and carry out appropriate landing procedure for RWY 02 as close as possible to EAT or ETA</p> <p>(c) If unable to effect a landing, refer to Singapore AIP for missed approach procedure</p>
3	<p>No clearance or instruction received from Singapore ATC</p> <p>- Refer to Singapore AIP for radio communications failure procedure</p>

**STANDARD ARRIVAL CHART
RNAV (GNSS) -
INSTRUMENT (STAR)**

ACC 133.8
APP 124.05
119.3
TWR 118.6 / 118.25

TRANSITION ALTITUDE 11 000ft

D-ATIS AP ID-WSSS 128.025

**SINGAPORE/Singapore Changi
RWY 20R/C/L
ELALO ONE BRAVO ARRIVAL
ELALO 1B**

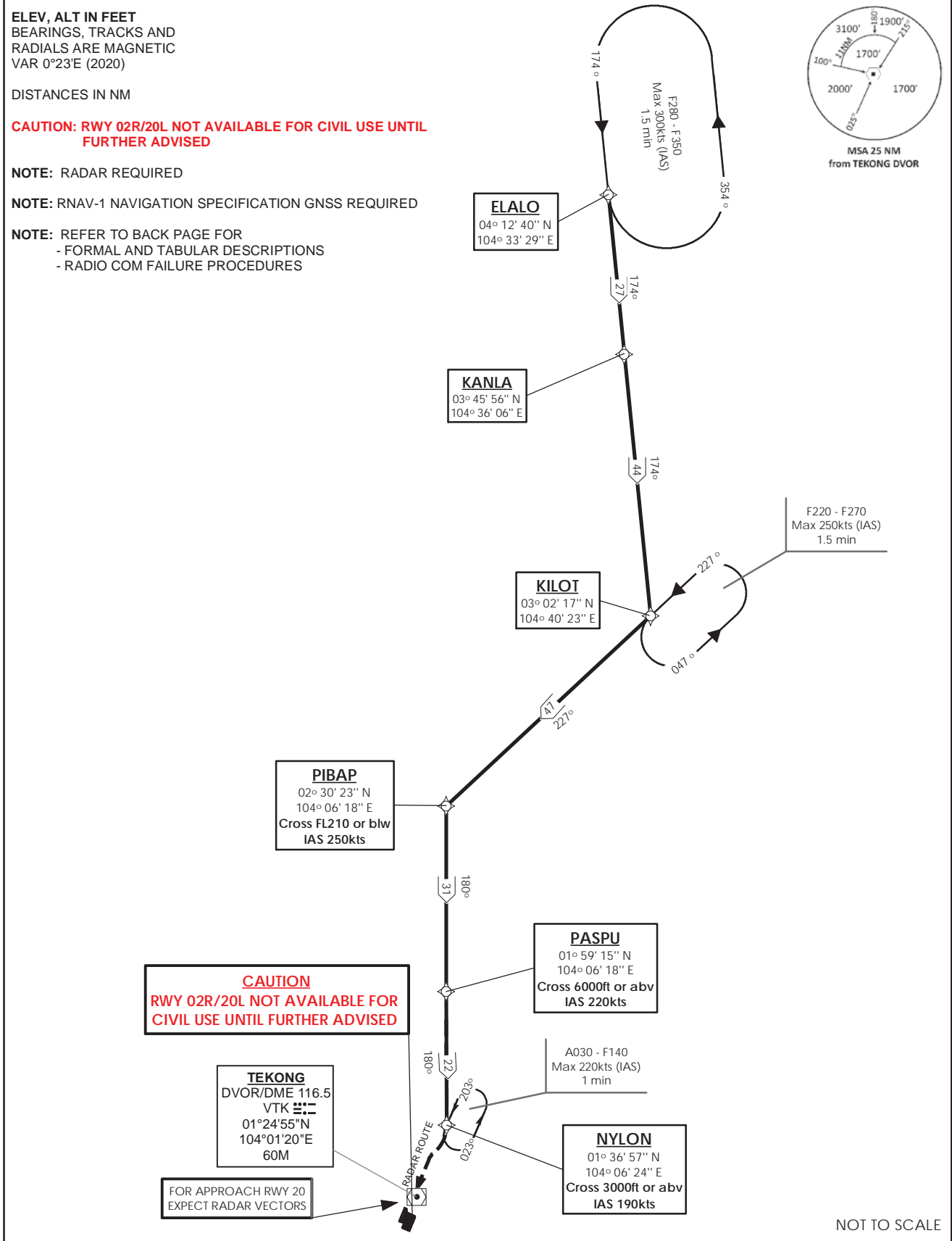

31 OCT 2024

ELALO 1B (STAR) RNAV GNSS RWY 20R/20C/20L - DESCRIPTIONS**Formal & Abbreviated Descriptions**

Formal Description	Abbreviated Description	Path Terminator	Fly-Over required
From ELALO.	ELALO -	IF	N
To KANLA.	KANLA -	TF	N
To KILOT, turn right.	KILOT [R] -	TF	N
To PIBAP at or below FL210, speed 250kts turn left.	PIBAP [FL210-; K250; L] -	TF	N
To PASPU, at or above 6000ft, speed 220kts.	PASPU [A060+; K220] -	TF	N
To NYLON at or above 3000ft, speed 190kts.	NYLON [A030+; K190]	TF	N

Tabular Descriptions

Path Term	Waypoint Name	Fly-Over	Course °M(°T)	Distance (NM)	Turn Direction	Altitude	Speed Limit	Navigation Spec
IF	ELALO	-	-	-	-	-	-	RNAV1
TF	KANLA	-	174(174.4)	27.0	-	-	-	RNAV1
TF	KILOT	-	174(174.4)	44.0	R	-	-	RNAV1
TF	PIBAP	-	227(227.4)	47.0	L	FL210-	K250	RNAV1
TF	PASPU	-	180(180.4)	31.0	-	A060+	K220	RNAV1
TF	NYLON	-	180(180.4)	22.0	-	A030+	K190	RNAV1

Radio Communications Failure Procedure

1	SET TRANSPONDER TO MODE A/C CODE 7600
2	<p>When cleared via ELALO 1B by Singapore ATC</p> <p>(a) Maintain last assigned flight level or altitude and proceed on ELALO 1B to NYLON</p> <p>(b) From NYLON commence descent and carry out appropriate landing procedure for RWY 20 as close as possible to EAT or ETA</p> <p>(c) If unable to effect a landing, refer to Singapore AIP for missed approach procedure</p>
3	<p>No clearance or instruction received from Singapore ATC</p> <p>- Refer to Singapore AIP for radio communications failure procedure</p>

SINGAPORE/Singapore Changi
RWY 02L/C/R
KARTO TWO ALPHA ARRIVAL
KARTO 2A

ACC 134.2 APP 124.05 119.3 TWR 118.6 / 118.25	TRANSITION ALTITUDE 11 000ft	D-ATIS AP ID-WSSS 128.025
--	---------------------------------	------------------------------

STANDARD ARRIVAL CHART
RNAV (GNSS) -
INSTRUMENT (STAR)

ELEV, ALT IN FEET
BEARINGS, TRACKS AND
RADIALS ARE MAGNETIC
VAR 0°23'E (2020)

DISTANCES IN NM

TEKONG
DVOR/DME 116.5
VTK
01° 24' 55"N
104° 01' 20" E
60m

CAUTION
RWY 02R/20L NOT AVAILABLE FOR
CIVIL USE UNTIL FURTHER ADVISED

FOR APPROACH RWY 02
EXPECT RADAR VECTORS

CAUTION: RWY 02R/20L NOT AVAILABLE FOR CIVIL USE UNTIL FURTHER ADVISED

NOTE: RADAR REQUIRED

NOTE: RNAV-1 NAVIGATION SPECIFICATION GNSS REQUIRED

NOTE: REFER TO BACK PAGE FOR
- FORMAL AND TABULAR DESCRIPTIONS
- RADIO COM FAILURE PROCEDURES

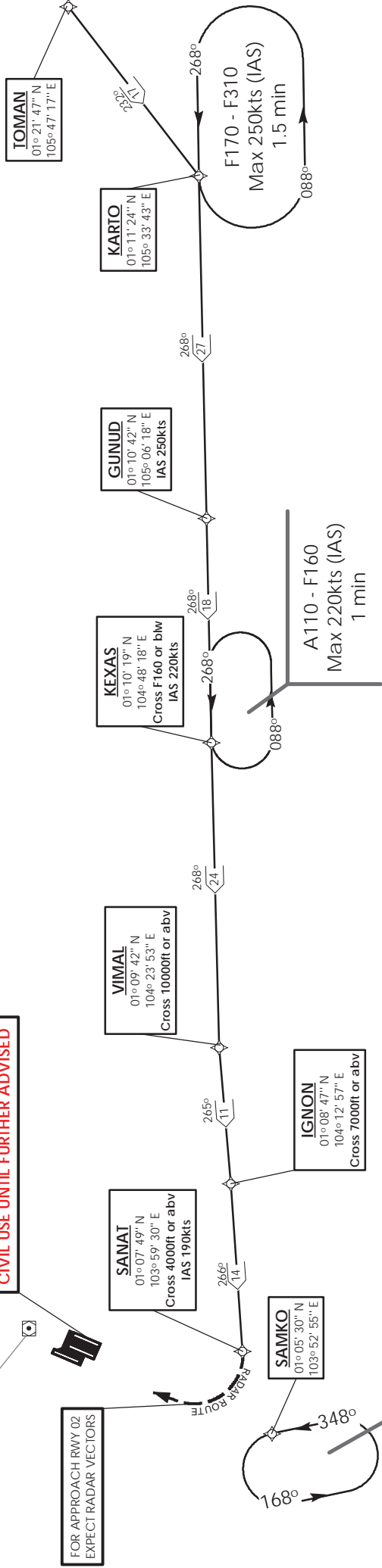
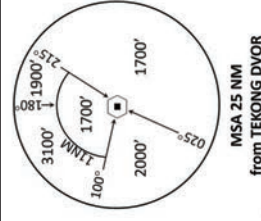

NOT TO SCALE

KARTO 2A (STAR) RNAV GNSS RWY 02L/02C/02R - DESCRIPTIONS

Formal & Abbreviated Descriptions

Formal Description	Abbreviated Description	Path Terminator	Fly-Over required
From TOMAN.	TOMAN -	IF	N
To KARTO, turn right.	KARTO [R] -	TF	N
To GUNUD, speed 250kts	GUNUD [K250] -	TF	N
To KEXAS at or below FL160, speed 220kts.	KEXAS [FL160-; K220] -	TF	N
To VIMAL at or above 10000ft, turn left.	VIMAL [A100+; L] -	TF	N
To IGNON at or above 7000ft, turn right.	IGNON [A070+; R] -	TF	N
To SANAT at or above 4000ft, speed 190kts.	SANAT [A040+; K190]	TF	N

Tabular Descriptions

Path Term	Waypoint Name	Fly-Over	Course °M(°T)	Distance (NM)	Turn Direction	Altitude	Speed Limit	Navigation Spec
IF	TOMAN	-	-	-	-	-	-	RNAV1
TF	KARTO	-	232(232.4)	17.0	R	-	-	RNAV1
TF	GUNUD	-	268(268.4)	27.0	-	-	K250	RNAV1
TF	KEXAS	-	268(268.4)	18.0	-	FL160-	K220	RNAV1
TF	VIMAL	-	268(268.4)	24.0	L	A100+	-	RNAV1
TF	IGNON	-	265(265.4)	11.0	R	A070+	-	RNAV1
TF	SANAT	-	266(266.4)	14.0	-	A040+	K190	RNAV1

Radio Communications Failure Procedure

1	SET TRANSPONDER TO MODE A/C CODE 7600
2	<p>When cleared via KARTO 2A by Singapore ATC</p> <p>(a) Maintain last assigned flight level or altitude and proceed on KARTO 2A to SANAT, then direct to SAMKO</p> <p>(b) From SAMKO commence descent and carry out appropriate landing procedure for RWY 02 as close as possible to EAT or ETA</p> <p>(c) If unable to effect a landing, refer to Singapore AIP for missed approach procedure</p>
3	<p>No clearance or instruction received from Singapore ATC</p> <p>- Refer to Singapore AIP for radio communications failure procedure</p>

31 OCT 2024

KARTO 2B (STAR) RNAV GNSS RWY 20R/20C/20L - DESCRIPTIONS**Formal & Abbreviated Descriptions**

Formal Description	Abbreviated Description	Path Terminator	Fly-Over required
From TOMAN.	TOMAN -	IF	N
To KARTO, turn right.	KARTO [R] -	TF	N
To GUNUD, speed 250kts.	GUNUD [K250] -	TF	N
To KEXAS at or below FL160, speed 220kts.	KEXAS [FL160-; K220] -	TF	N
To LAVAX at or above 10000ft, turn right.	LAVAX [A100+; R] -	TF	N
To DOVAN at or above 4000ft, turn right.	DOVAN [A040+; R] -	TF	N
To BIPOP at or above 3000ft, speed 190kts.	BIPOP [A030+; K190]	TF	N

Tabular Descriptions

Path Term	Waypoint Name	Fly-Over	Course °M(°T)	Distance (NM)	Turn Direction	Altitude	Speed Limit	Navigation Spec
IF	TOMAN	-	-	-	-	-	-	RNAV1
TF	KARTO	-	232(232.4)	17.0	R	-	-	RNAV1
TF	GUNUD	-	268(268.4)	27.0	-	-	K250	RNAV1
TF	KEXAS	-	268(268.4)	18.0	-	FL160-	K220	RNAV1
TF	LAVAX	-	268(268.4)	21.0	R	A100+	-	RNAV1
TF	DOVAN	-	304(304.4)	17.0	R	A040+	-	RNAV1
TF	BIPOP	-	347(347.4)	12.0	-	A030+	K190	RNAV1

Radio Communications Failure Procedure

1	SET TRANSPONDER TO MODE A/C CODE 7600
2	<p>When cleared via KARTO 2B by Singapore ATC</p> <p>(a) Maintain last assigned flight level or altitude and proceed on KARTO 2B to BIPOP, then direct to NYLON</p> <p>(b) From NYLON commence descent and carry out appropriate landing procedure for RWY 20 as close as possible to EAT or ETA</p> <p>(c) If unable to effect a landing, refer to Singapore AIP for missed approach procedure</p>
3	<p>No clearance or instruction received from Singapore ATC</p> <p>- Refer to Singapore AIP for radio communications failure procedure</p>

**STANDARD ARRIVAL CHART
RNAV (GNSS) -
INSTRUMENT (STAR)**

ACC 133.8
APP 124.05
119.3
TWR 118.6

TRANSITION ALTITUDE
11 000ft

D-ATIS AP ID-WSSS
128.025

**SINGAPORE/Singapore Changi
RWY 02L/C/R
LEBAR TWO ALPHA ARRIVAL
LEBAR 2A**

ELEV. ALT IN FEET
BEARINGS, TRACKS AND
RADIALS ARE MAGNETIC
VAR 0°23'E (2020)

DISTANCES IN NM

**CAUTION: RWY 02R/20L NOT AVAILABLE FOR CIVIL USE UNTIL
FURTHER ADVISED**

NOTE: RADAR REQUIRED

NOTE: RNAV-1 NAVIGATION SPECIFICATION GNSS REQUIRED

NOTE: REFER TO BACK PAGE FOR
- FORMAL AND TABULAR DESCRIPTIONS
- RADIO COM FAILURE PROCEDURES

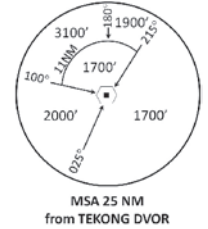

PASPU
01° 59' 15" N
104° 06' 18" E
IAS 220kts

PAPA UNIFORM
DVOR/DME 115.1
PU :---
01° 25' 24" N
103° 56' 00" E
60M
Cross 7,000ft or abv

TEKONG
DVOR/DME 116.5
VTK :---
01° 24' 55" N
104° 01' 20" E
60M

DEVIATION IS NOT PERMITTED
BETWEEN SJ AND PU

CAUTION
RWY 02R/20L NOT AVAILABLE FOR
CIVIL USE UNTIL FURTHER ADVISED

WSR38
10,000ft ALT
GND

SINJON
DVOR/DME 113.5
SJ :---
01° 13' 21.34" N
103° 51' 15.22" E
58M
Cross 7,000ft or abv

PALGA
01° 10' 59" N
103° 47' 59" E
IAS 220kts

PAMSI
01° 04' 59" N
103° 48' 45" E

SAMKO
01° 05' 30" N
103° 52' 55" E
Cross 4,000ft or abv
IAS 190kts

FOR APPROACH RWY 02
EXPECT RADAR VECTORS

RADAR ROUTE

NOT TO SCALE

LEBAR 2A (STAR) RNAV GNSS RWY 02L/02C/02R - DESCRIPTIONS

Formal & Abbreviated Descriptions

Formal Description	Abbreviated Description	Path Terminator	Fly-Over required
From PASPU, speed 220kts.	PASPU [K220] -	IF	N
To PU at or above 7000ft, turn right.	PU [A070+; R] -	TF	N
To SJ at or above 7000ft, turn right.	SJ [A070+; R] -	TF	N
To PALGA, speed 220kts, turn left.	PALGA [K220; L] -	TF	N
To PAMSI, turn left.	PAMSI [L] -	TF	N
To SAMKO at or above 4000ft, speed 190kts.	SAMKO [A040+; K190]	TF	N

Tabular Descriptions

Path Term	Waypoint Name	Fly-Over	Course °M(°T)	Distance (NM)	Turn Direction	Altitude	Speed Limit	Navigation Spec
IF	PASPU	-	-	-	-	-	K220	RNAV1
TF	PU	-	197(197.4)	35.0	R	A070+	-	RNAV1
TF	SJ	-	202(202.4)	13.0	R	A070+	-	RNAV1
TF	PALGA	-	234(234.4)	4.0	L	-	K220	RNAV1
TF	PAMSI	-	173(173.4)	6.0	L	-	-	RNAV1
TF	SAMKO	-	082(082.4)	4.0	-	A040+	K190	RNAV1

Radio Communications Failure Procedure

1	SET TRANSPONDER TO MODE A/C CODE 7600
2	<p>When cleared via LEBAR 2A by Singapore ATC</p> <p>(a) Maintain last assigned flight level or altitude and proceed on LEBAR 2A to SAMKO</p> <p>(b) From SAMKO commence descent and carry out appropriate landing procedure for RWY 02L as close as possible to EAT or ETA</p> <p>(c) If unable to effect a landing, refer to Singapore AIP for missed approach procedure</p>
3	<p>No clearance or instruction received from Singapore ATC</p> <p>- Refer to Singapore AIP for radio communications failure procedure</p>

STANDARD ARRIVAL CHART
RNAV (GNSS) -
INSTRUMENT (STAR)

ACC 134.4
APP 124.6
119.3
TWR 118.6 / 118.25

TRANSITION ALTITUDE 11 000ft
D-ATIS AP ID-WSSS 128.025

SINGAPORE/Singapore Changi
RWY 20R/C/L
LEBAR THREE BRAVO ARRIVAL
LEBAR 3B

ELEV, ALT IN FEET
BEARINGS, TRACKS AND
RADIALS ARE MAGNETIC
VAR 0°23'E (2020)

DISTANCES IN NM

CAUTION: RWY 02R/20L NOT AVAILABLE FOR CIVIL USE UNTIL FURTHER ADVISED

NOTE: RADAR REQUIRED

NOTE: RNAV-1 NAVIGATION SPECIFICATION GNSS REQUIRED

NOTE: REFER TO BACK PAGE FOR
- FORMAL AND TABULAR DESCRIPTIONS
- RADIO COM FAILURE PROCEDURES

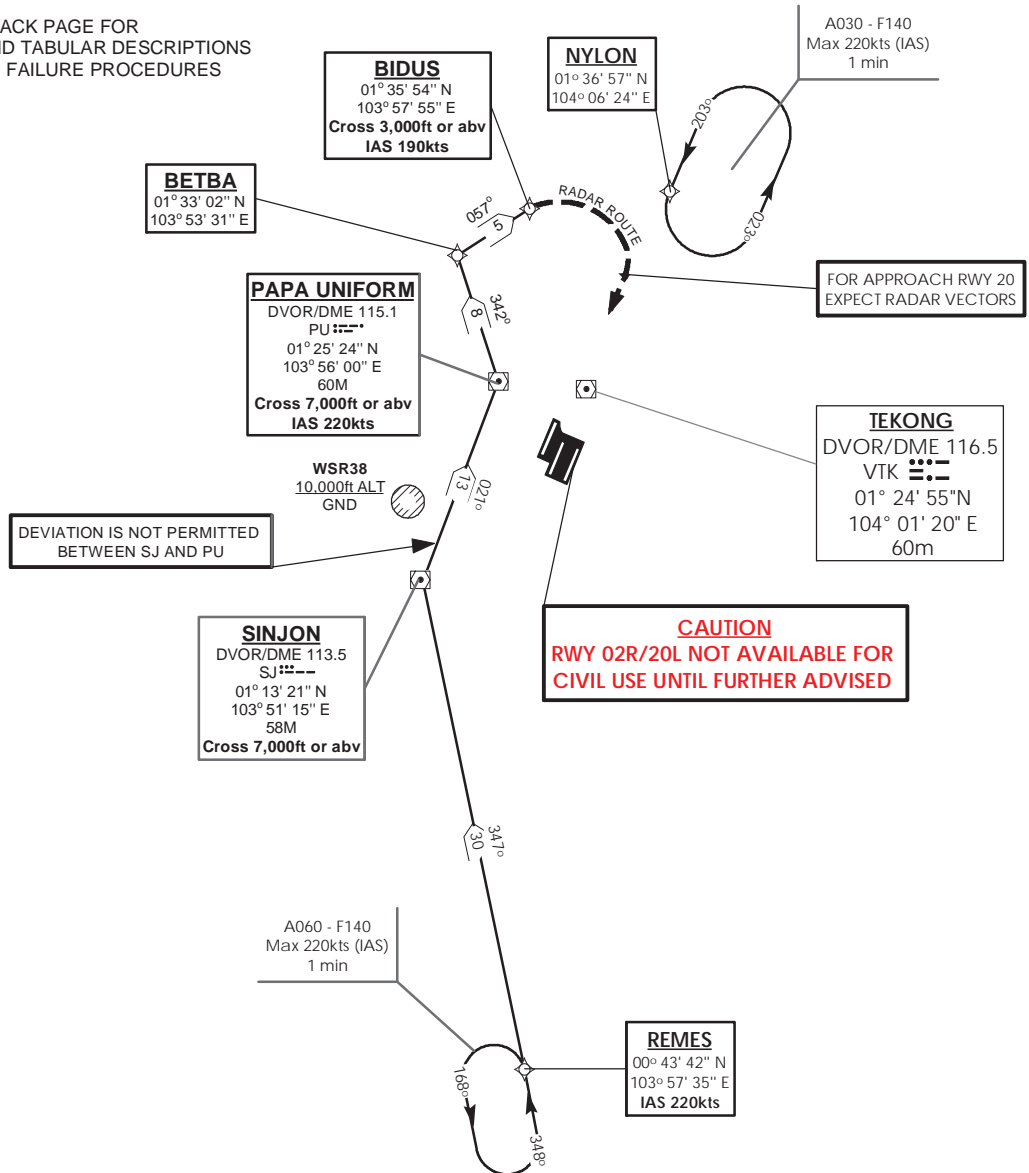
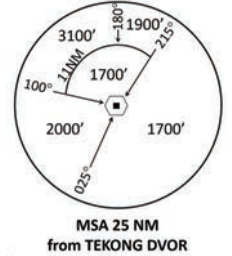

NOT TO SCALE

LEBAR 3B (STAR) RNAV GNSS RWY 20R/20C/20L - DESCRIPTIONS

Formal & Abbreviated Descriptions

Formal Description	Abbreviated Description	Path Terminator	Fly-Over required
From REMES, speed 220kts.	REMES [K220] -	IF	N
To SJ at or above 7000ft, turn right.	SJ [A070+; R] -	TF	N
To PU at or above 7000ft, speed 220kts, turn left.	PU [A070+; K220; L] -	TF	N
To BETBA, turn right.	BETBA [R] -	TF	N
To BIDUS at or above 3000ft, speed 190kts.	BIDUS [A030+; K190]	TF	N

Tabular Descriptions

Path Term	Waypoint Name	Fly-Over	Course °M(°T)	Distance (NM)	Turn Direction	Altitude	Speed Limit	Navigation Spec
IF	REMES	-	-	-	-	-	K220	RNAV1
TF	SJ	-	347(347.4)	30.0	R	A070+	-	RNAV1
TF	PU	-	021(021.4)	13.0	L	A070+	K220	RNAV1
TF	BETBA	-	342(342.4)	8.0	R	-	-	RNAV1
TF	BIDUS	-	057(057.4)	5.0	-	A030+	K190	RNAV1

Radio Communications Failure Procedure

1	SET TRANSPONDER TO MODE A/C CODE 7600
2	<p>When cleared via LEBAR 3B by Singapore ATC</p> <p>(a) Maintain last assigned flight level or altitude and proceed on LEBAR 3B to BIDUS, then direct to NYLON</p> <p>(b) From NYLON commence descent and carry out appropriate landing procedure for RWY 20 as close as possible to EAT or ETA</p> <p>(c) If unable to effect a landing, refer to Singapore AIP for missed approach procedure</p>
3	<p>No clearance or instruction received from Singapore ATC</p> <p>- Refer to Singapore AIP for radio communications failure procedure</p>

**STANDARD ARRIVAL CHART
RNAV (GNSS) -
INSTRUMENT (STAR)**

ACC 133.25
APP 124.6
119.3
TWR 118.6 / 118.25

TRANSITION ALTITUDE
11 000ft

D-ATIS AP ID-WSSS
128.025

**SINGAPORE/Singapore Changi
RWY 20R/C/L
LELIB THREE BRAVO ARRIVAL
LELIB 3B**

ELEV, ALT IN FEET
BEARINGS, TRACKS AND
RADIALS ARE MAGNETIC
VAR 0°23'E (2020)

DISTANCES IN NM

CAUTION: RWY 02R/20L NOT AVAILABLE FOR CIVIL USE UNTIL FURTHER ADVISED

NOTE: RADAR REQUIRED

NOTE: RNAV-1 NAVIGATION SPECIFICATION GNSS REQUIRED

NOTE: REFER TO BACK PAGE FOR
- FORMAL AND TABULAR DESCRIPTIONS
- RADIO COM FAILURE PROCEDURES

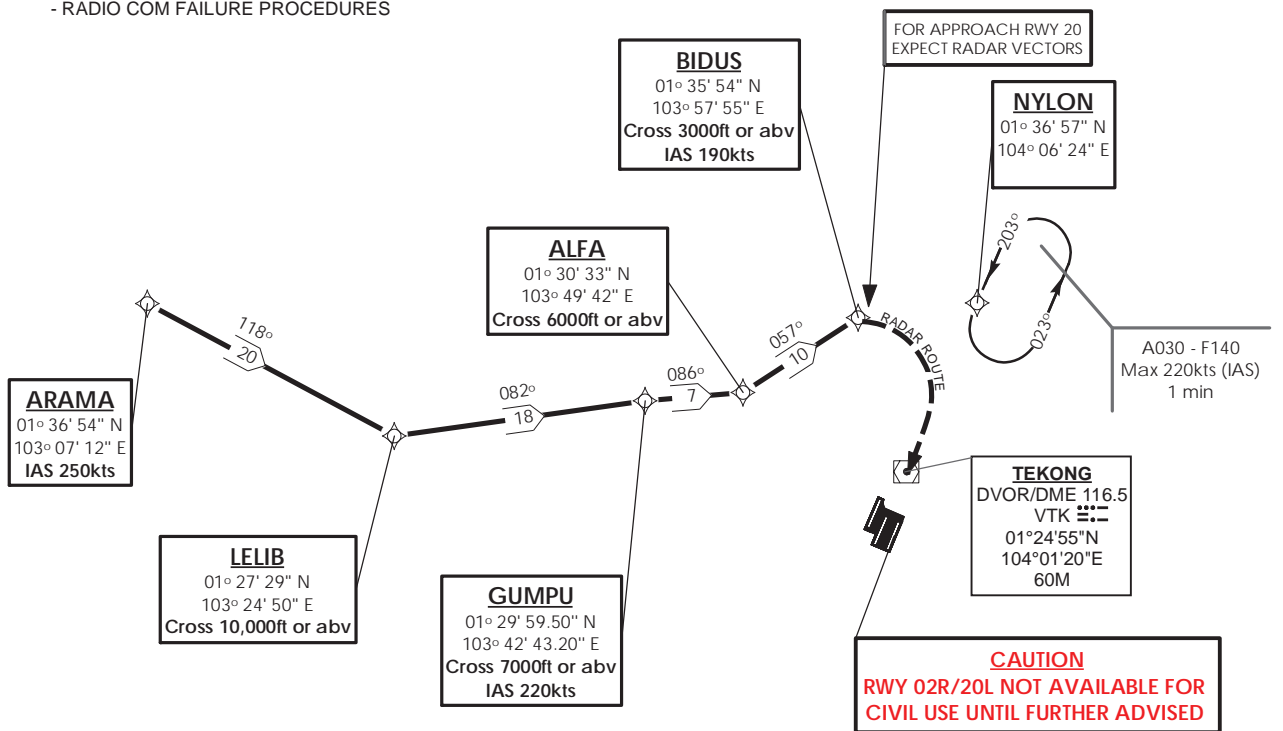
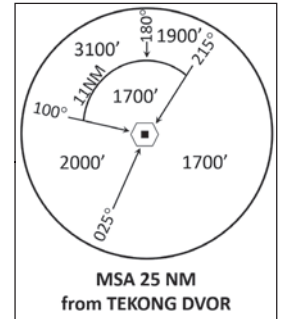

TEBUN 1B shall be the default STAR for WSSS RWY 20.
ATC will offer LELIB 3B when traffic permits.

NOT TO SCALE

LELIB 3B (STAR) RNAV GNSS RWY 20R/20C/20L - DESCRIPTIONS

Formal & Abbreviated Descriptions

Formal Description	Abbreviated Description	Path Terminator	Fly-Over required
From ARAMA, speed 250kts.	ARAMA [K250] -	IF	N
To LELIB at or above 10000ft, turn left.	LELIB [A100+; L] -	TF	N
To GUMPU at or above 7000ft, speed 220kts, turn right.	GUMPU [A070+; K220; R] -	TF	N
To ALFA at or above 6000ft, turn left.	ALFA [A060+; L] -	TF	N
To BIDUS at or above 3000ft, speed 190kts.	BIDUS [A030+; K190]	TF	N

Tabular Descriptions

Path Term	Waypoint Name	Fly-Over	Course °M(°T)	Distance (NM)	Turn Direction	Altitude	Speed Limit	Navigation Spec
IF	ARAMA	-	-	-	-	-	K250	RNAV1
TF	LELIB	-	118(118.4)	20.0	L	A100+	-	RNAV1
TF	GUMPU	-	082(082.4)	18.0	R	A070+	K220	RNAV1
TF	ALFA	-	086(086.4)	7.0	L	A060+	-	RNAV1
TF	BIDUS	-	057(057.4)	10.0	-	A030+	K190	RNAV1

Radio Communications Failure Procedure

1	SET TRANSPONDER TO MODE A/C CODE 7600
2	<p>When cleared via LELIB 3B by Singapore ATC</p> <p>(a) Maintain last assigned flight level or altitude and proceed on LELIB 3B to BIDUS, then direct to NYLON</p> <p>(b) From NYLON commence descent and carry out appropriate landing procedure for RWY 20 as close as possible to EAT or ETA</p> <p>(c) If unable to effect a landing, refer to Singapore AIP for missed approach procedure</p>
3	<p>No clearance or instruction received from Singapore ATC</p> <p>- Refer to Singapore AIP for radio communications failure procedure</p>

STANDARD ARRIVAL CHART
RNAV (GNSS) -
INSTRUMENT (STAR)

ACC 133.8
APP 124.05
119.3
TWR 118.6 / 118.25

TRANSITION ALTITUDE 11 000ft
D-ATIS AP ID-WSSS 128.025

SINGAPORE/Singapore Changi
RWY 02L/C/R
MABAL TWO ALPHA ARRIVAL
MABAL 2A

ELEV, ALT IN FEET
BEARINGS, TRACKS AND
RADIALS ARE MAGNETIC
VAR 0°23'E (2020)

DISTANCES IN NM

CAUTION: RWY 02R/20L NOT AVAILABLE FOR CIVIL USE UNTIL FURTHER ADVISED

NOTE: RADAR REQUIRED

NOTE: RNAV-1 NAVIGATION SPECIFICATION GNSS REQUIRED

NOTE: REFER TO BACK PAGE FOR
- FORMAL AND TABULAR DESCRIPTIONS
- RADIO COM FAILURE PROCEDURES

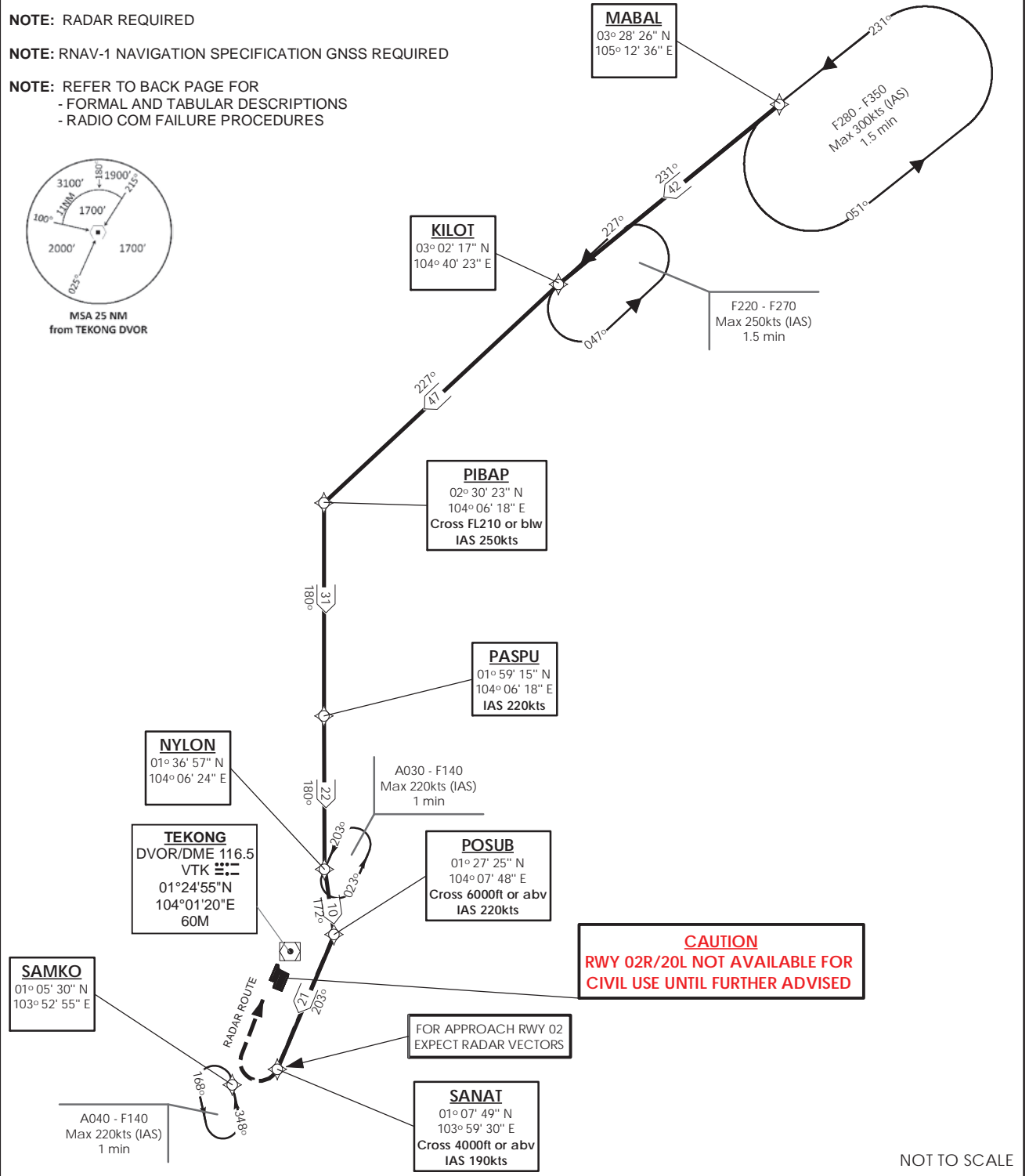
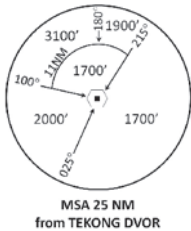

31 OCT 2024

MABAL 2A (STAR) RNAV GNSS RWY 02L/02C/02R - DESCRIPTIONS**Formal & Abbreviated Descriptions**

Formal Description	Abbreviated Description	Path Terminator	Fly-Over required
From MABAL.	MABAL -	IF	N
To KILOT, turn left.	KILOT [L] -	TF	N
To PIBAP at or below FL210, speed 250kts, turn left.	MABAL -	TF	N
To PASPU, speed 220kts.	PASPU [K220] -	TF	N
To NYLON, turn left.	NYLON [L] -	TF	N
To POSUB at or above 6000ft, speed 220kts, turn right.	POSUB [A060+; K220; R] -	TF	N
To SANAT at or above 4000ft, speed 190kts.	SANAT [A040+; K190]	TF	N

Tabular Descriptions

Path Term	Waypoint Name	Fly-Over	Course °M(°T)	Distance	Turn Direction	Altitude	Speed Limit	Navigation Spec
IF	MABAL	-	-	-	-	-	-	RNAV1
TF	KILOT	-	231(231.4)	42.0	L	-	-	RNAV1
TF	PIBAP	-	227(227.4)	47.0	L	FL210-	K250	RNAV1
TF	PASPU	-	180(180.4)	31.0	-	-	K220	RNAV1
TF	NYLON	-	180(180.4)	22.0	L	-	-	RNAV1
TF	POSUB	-	172(172.4)	10.0	R	A060+	K220	RNAV1
TF	SANAT	-	203(203.4)	21.0	-	A040+	K190	RNAV1

Radio Communications Failure Procedure

1	SET TRANSPONDER TO MODE A/C CODE 7600
2	<p>When cleared via MABAL 2A by Singapore ATC</p> <p>(a) Maintain last assigned flight level or altitude and proceed on MABAL 2A to SANAT, then direct to SAMKO</p> <p>(b) From SAMKO commence descent and carry out appropriate landing procedure for RWY 02 as close as possible to EAT or ETA</p> <p>(c) If unable to effect a landing, refer to Singapore AIP for missed approach procedure</p>
3	<p>No clearance or instruction received from Singapore ATC</p> <p>- Refer to Singapore AIP for radio communications failure procedure</p>

STANDARD ARRIVAL CHART
RNAV (GNSS) -
INSTRUMENT (STAR)

ACC 133.8
APP 124.05
119.3
TWR 118.6 / 118.25

TRANSITION ALTITUDE
11 000ft

D-ATIS AP ID-WSSS
128.025

SINGAPORE/Singapore Changi
RWY 20R/C/L
MABAL TWO BRAVO ARRIVAL
MABAL 2B

ELEV, ALT IN FEET
BEARINGS, TRACKS AND
RADIALS ARE MAGNETIC
VAR 0°23'E (2020)

DISTANCES IN NM

CAUTION: RWY 02R/20L NOT AVAILABLE FOR CIVIL USE UNTIL FURTHER ADVISED

NOTE: RADAR REQUIRED

NOTE: RNAV-1 NAVIGATION SPECIFICATION GNSS REQUIRED

NOTE: REFER TO BACK PAGE FOR
- FORMAL AND TABULAR DESCRIPTIONS
- RADIO COM FAILURE PROCEDURES

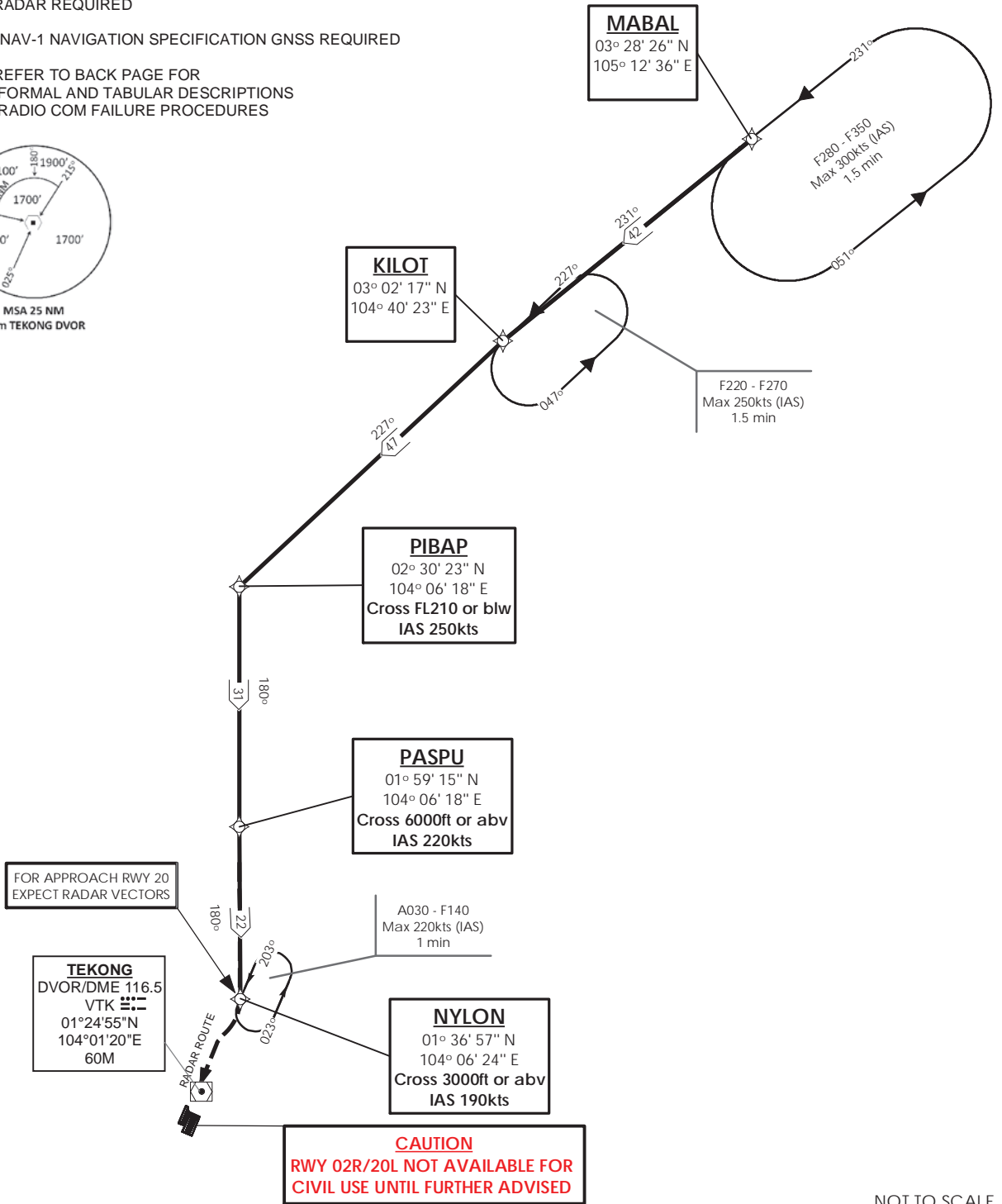
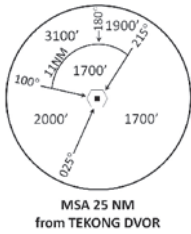

NOT TO SCALE

31 OCT 2024

MABAL 2B (STAR) RNAV GNSS RWY 20R/20C/20L - DESCRIPTIONS**Formal & Abbreviated Descriptions**

Formal Description	Abbreviated Description	Path Terminator	Fly-Over required
From MABAL.	MABAL -	IF	N
To KILOT, turn left.	KILOT [L] -	TF	N
To PIBAP at or below FL210, speed 250kts, turn left.	PIBAP [FL210-; K250; L] -	TF	N
To PASPU, at or above 6000ft, speed 220kts.	PASPU [A060+; K220] -	TF	N
To NYLON at or above 3000ft, speed 190kts.	NYLON [A030+; K190]	TF	N

Tabular Descriptions

Path Term	Waypoint Name	Fly-Over	Course °M(°T)	Distance (NM)	Turn Direction	Altitude	Speed Limit	Navigation Spec
IF	MABAL	-	-	-	-	-	-	RNAV1
TF	KILOT	-	231(231.4)	42.0	L	-	-	RNAV1
TF	PIBAP	-	227(227.4)	47.0	L	FL210-	K250	RNAV1
TF	PASPU	-	180(180.4)	31.0	-	A060+	K220	RNAV1
TF	NYLON	-	180(180.4)	22.0	-	A030+	K190	RNAV1

Radio Communications Failure Procedure

1	SET TRANSPONDER TO MODE A/C CODE 7600
2	<p>When cleared via MABAL 2B by Singapore ATC</p> <p>(a) Maintain last assigned flight level or altitude and proceed on MABAL 2B to NYLON</p> <p>(b) From NYLON commence descent and carry out appropriate landing procedure for RWY 20 as close as possible to EAT or ETA</p> <p>(c) If unable to effect a landing, refer to Singapore AIP for missed approach procedure</p>
3	<p>No clearance or instruction received from Singapore ATC</p> <p>- Refer to Singapore AIP for radio communications failure procedure</p>

STANDARD ARRIVAL CHART
RNAV (GNSS) -
INSTRUMENT (STAR)

ACC 134.4
APP 124.6
119.3
TWR 118.6 / 118.25

TRANSITION ALTITUDE
11 000ft

D-ATIS AP ID-WSSS
128.025

SINGAPORE/Singapore Changi
RWY 02L/C/R
REPOV TWO ALPHA ARRIVAL
REPOV 2A

ELEV, ALT IN FEET
BEARINGS, TRACKS AND
RADIALS ARE MAGNETIC
VAR 0°23'E (2020)

DISTANCES IN NM

CAUTION: RWY 02R/20L NOT AVAILABLE FOR CIVIL USE UNTIL FURTHER ADVISED

NOTE: RADAR REQUIRED

NOTE: RNAV-1 NAVIGATION SPECIFICATION GNSS REQUIRED

NOTE: REFER TO BACK PAGE FOR
- FORMAL AND TABULAR DESCRIPTIONS
- RADIO COM FAILURE PROCEDURES

TEKONG
DVOR/DME 116.5
VTK 
01° 24' 55" N
104° 01' 20" E
60m

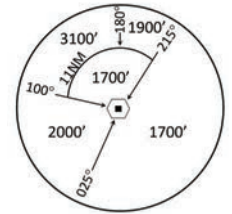

MSA 25 NM
from TEKONG DVOR

CAUTION
RWY 02R/20L NOT AVAILABLE FOR CIVIL USE UNTIL FURTHER ADVISED

FOR APPROACH RWY 02
EXPECT RADAR VECTORS

SAMKO
01° 05' 30" N
103° 52' 55" E
Cross 4000ft or abv
IAS 190kts

DUMUP
00° 54' 30" N
103° 55' 16" E
Cross 7000ft or abv

REMES
00° 43' 42" N
103° 57' 35" E
IAS 220kts

A060 - F140
Max 220kts (IAS)
1 min

REPOV
00° 16' 23" N
104° 03' 00" E
Cross FL210 or blw
IAS 250kts

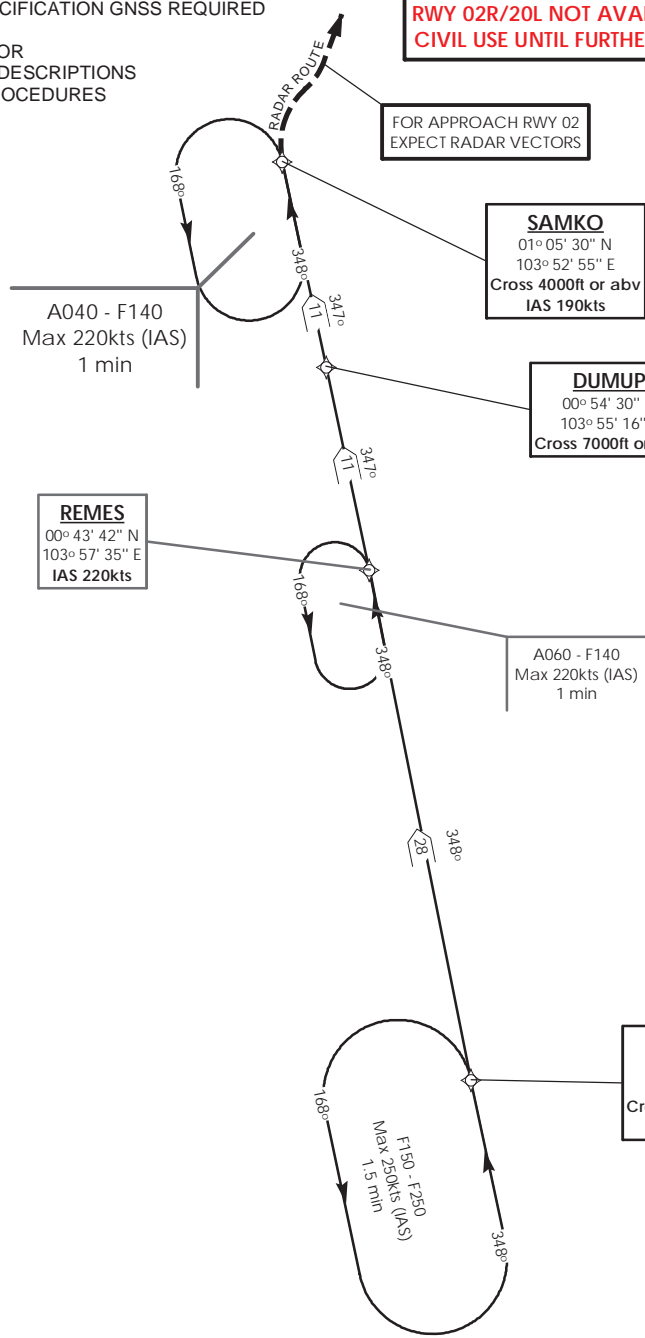

NOT TO SCALE

31 OCT 2024

REPOV 2A (STAR) RNAV GNSS RWY 02L/02C/02R - DESCRIPTIONS**Formal & Abbreviated Descriptions**

Formal Description	Abbreviated Description	Path Terminator	Fly-Over required
From REPOV at or below FL210, speed 250kts.	REPOV [FL210-; K250] -	IF	N
To REMES, speed 220kts, turn left.	REMES [K220; L] -	TF	N
To DUMUP at or above 7000ft.	DUMUP [A070+] -	TF	N
To SAMKO at or above 4000ft, speed 190kts.	SAMKO [A040+; K190]	TF	N

Tabular Descriptions

Path Term	Waypoint Name	Fly-Over	Course °M(°T)	Distance (NM)	Turn Direction	Altitude	Speed Limit	Navigation Spec
IF	REPOV	-	-	-	-	FL210-	K250	RNAV1
TF	REMES	-	348(348.4)	28.0	L	-	K220	RNAV1
TF	DUMUP	-	347(347.4)	11.0	-	A070+	-	RNAV1
TF	SAMKO	-	347(347.4)	11.0	-	A040+	K190	RNAV1

Radio Communications Failure Procedure

1	SET TRANSPONDER TO MODE A/C CODE 7600
2	<p>When cleared via REPOV 2A by Singapore ATC</p> <p>(a) Maintain last assigned flight level or altitude and proceed on REPOV 2A to SAMKO</p> <p>(b) From SAMKO commence descent and carry out appropriate landing procedure for RWY 02 as close as possible to EAT or ETA</p> <p>(c) If unable to effect a landing, refer to Singapore AIP for missed approach procedure</p>
3	<p>No clearance or instruction received from Singapore ATC</p> <p>- Refer to Singapore AIP for radio communications failure procedure</p>

STANDARD ARRIVAL CHART
RNAV (GNSS) -
INSTRUMENT (STAR)

ACC 134.4
APP 124.6
119.3
TWR 118.6 / 118.25

TRANSITION ALTITUDE
11 000ft

D-ATIS AP ID-WSSS
128.025

SINGAPORE/Singapore Changi
RWY 20R/C/L
REPOV TWO BRAVO ARRIVAL
REPOV 2B

ELEV, ALT IN FEET
BEARINGS, TRACKS AND
RADIALS ARE MAGNETIC
VAR 0°23'E (2020)

DISTANCES IN NM

CAUTION: RWY 02R/20L NOT AVAILABLE FOR CIVIL USE UNTIL FURTHER ADVISED

NOTE: RADAR REQUIRED

NOTE: RNAV-1 NAVIGATION SPECIFICATION GNSS REQUIRED

NOTE: REFER TO BACK PAGE FOR
- FORMAL AND TABULAR DESCRIPTIONS
- RADIO COM FAILURE PROCEDURES

TEKONG
DVOR/DME 116.5
VTK 
01° 24' 55"N
104° 01' 20" E
60m

CAUTION
RWY 02R/20L NOT AVAILABLE FOR CIVIL USE UNTIL FURTHER ADVISED

NYLON
01° 36' 57" N
104° 06' 24" E

FOR APPROACH RWY 20
EXPECT RADAR VECTORS

A030 - F140
Max 220kts (IAS)
1 min

BIPOP
01° 31' 22" N
104° 10' 18" E
Cross 3000ft or abv
IAS 190kts

DOVAN
01° 19' 38" N
104° 12' 49" E
Cross 4000ft or abv

BITAM
01° 08' 13" N
104° 07' 57" E
Cross 7000ft or abv

A060 - F140
Max 220kts (IAS)
1 min

REMES
00° 43' 42" N
103° 57' 35" E
IAS 220kts

REPOV
00° 16' 23" N
104° 03' 00" E
Cross FL210 or blw
IAS 250kts

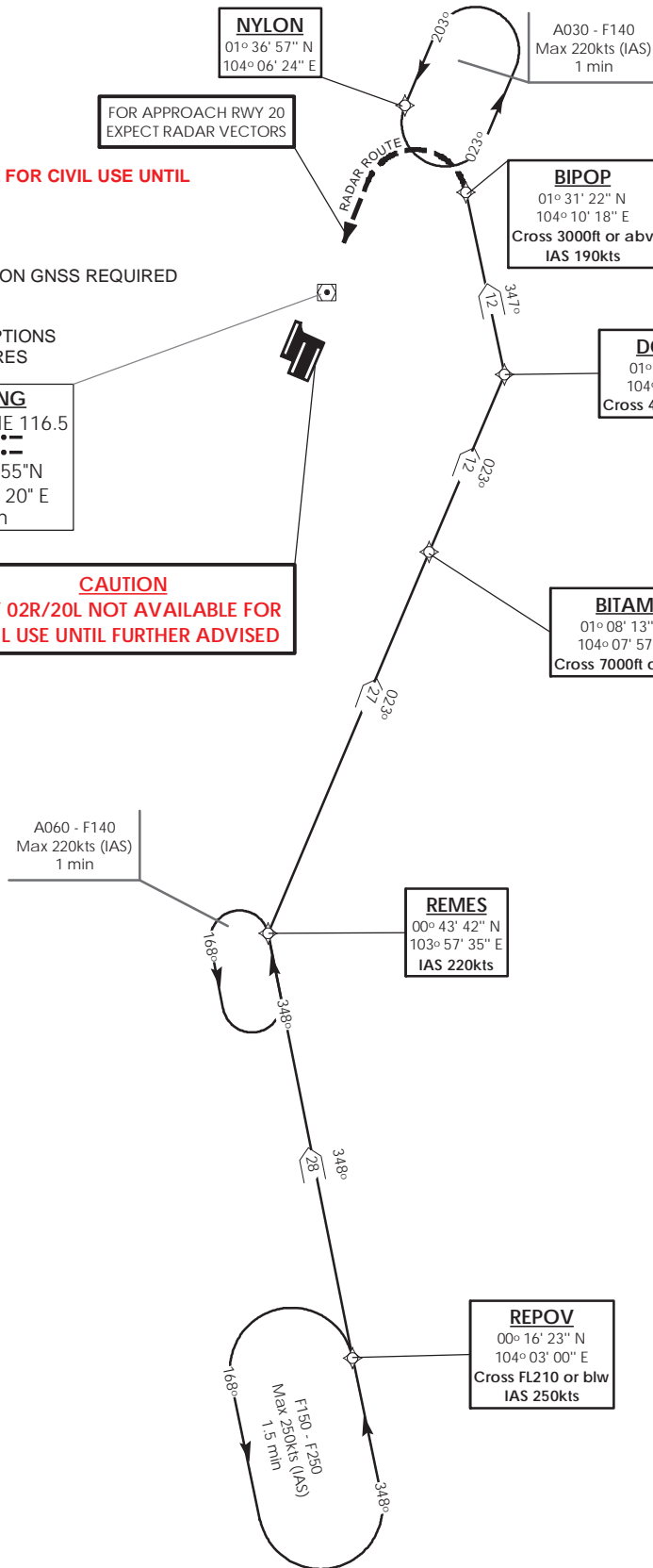
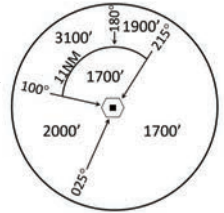

NOT TO SCALE

31 OCT 2024

REPOV 2B (STAR) RNAV GNSS RWY 20R/20C/20L - DESCRIPTIONS**Formal & Abbreviated Descriptions**

Formal Description	Abbreviated Description	Path Terminator	Fly-Over required
From REPOV at or below FL210, speed 250kts.	REPOV [FL210-; K250] -	IF	N
To REMES, speed 220kts, turn right.	REMES [K220; R] -	TF	N
To BITAM at or above 7000ft.	BITAM [A070+] -	TF	N
To DOVAN at or above 4000ft, turn left.	DOVAN [A040+; L] -	TF	N
To BIPOP at or above 3000ft, speed 190kts.	BIPOP [A030+; K190]	TF	N

Tabular Descriptions

Path Term	Waypoint Name	Fly-Over	Course °M(°T)	Distance (NM)	Turn Direction	Altitude	Speed Limit	Navigation Spec
IF	REPOV	-	-	-	-	FL210-	K250	RNAV1
TF	REMES	-	348(348.4)	28.0	R	-	K220	RNAV1
TF	BITAM	-	023(023.4)	27.0	-	A070+	-	RNAV1
TF	DOVAN	-	023(023.4)	12.0	L	A040+	-	RNAV1
TF	BIPOP	-	347(347.4)	12.0		A030+	K190	RNAV1

Radio Communications Failure Procedure

1	SET TRANSPONDER TO MODE A/C CODE 7600
2	<p>When cleared via REPOV 2B by Singapore ATC</p> <p>(a) Maintain last assigned flight level or altitude and proceed on REPOV 2B to BIPOP, then direct to NYLON</p> <p>(b) From NYLON commence descent and carry out appropriate landing procedure for RWY 20 as close as possible to EAT or ETA</p> <p>(c) If unable to effect a landing, refer to Singapore AIP for missed approach procedure</p>
3	<p>No clearance or instruction received from Singapore ATC</p> <p>- Refer to Singapore AIP for radio communications failure procedure</p>

**STANDARD ARRIVAL CHART
RNAV (GNSS) -
INSTRUMENT (STAR)**

ACC 133.25
APP 124.6
119.3
TWR 118.6 / 118.25

TRANSITION ALTITUDE
11 000ft

D-ATIS AP ID-WSSS
ARR 128.025

**SINGAPORE/Singapore Changi
RWY 02L/C/R
TEBUN ONE ALPHA ARRIVAL
TEBUN 1A**

ELEV, ALT IN FEET
BEARINGS, TRACKS AND
RADIALS ARE MAGNETIC
VAR 0°23'E (2020)

DISTANCES IN NM

**CAUTION: RWY 02R/20L NOT AVAILABLE FOR CIVIL USE UNTIL
FURTHER ADVISED**

NOTE: RADAR REQUIRED

NOTE: RNAV-1 NAVIGATION SPECIFICATION GNSS REQUIRED

NOTE: REFER TO BACK PAGE FOR
- FORMAL AND TABULAR DESCRIPTIONS
- RADIO COM FAILURE PROCEDURES

NOTE: FLIGHT PLANNING INSTRUCTIONS:
- AIRCRAFT TO FLY ARAMA DIRECT TO TEBUN
TO JOIN TEBUN 1A STAR

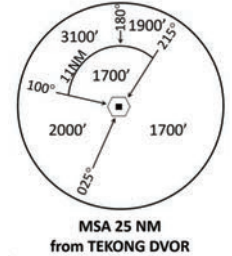

**CAUTION
RWY 02R/20L NOT AVAILABLE FOR
CIVIL USE UNTIL FURTHER ADVISED**

TEKONG
DVOR/DME 116.5
VTK
01° 24' 55" N
104° 01' 20" E
60m

TEBUN
01° 14' 55" N
103° 15' 57" E
IAS 250kts

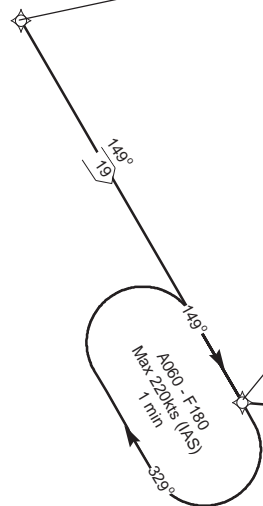

VAMPO
00° 58' 33" N
103° 25' 25" E
Cross 10,000ft or abv
IAS 220kts

FOR APPROACH RWY 02
EXPECT RADAR VECTORS



SAMKO
01° 05' 30" N
103° 52' 55" E
Cross 4000ft or abv
IAS 190kts

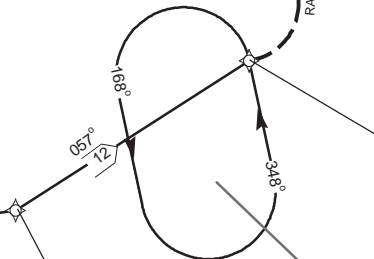

A040 - F140
Max 220kts (IAS)
1 min

VEXEL
00° 59' 04" N
103° 42' 54" E

IBASU
00° 57' 51" N
103° 34' 10" E

NOT TO SCALE

TEBUN 1A (STAR) RNAV GNSS RWY 02L/02C/02R - DESCRIPTIONS

Formal & Abbreviated Descriptions

Formal Description	Abbreviated Description	Path Terminator	Fly-Over required
From TEBUN, Speed 250kts.	TEBUN [K250] -	IF	N
To VAMPO at or above 10000ft, speed 220kts, turn left.	VAMPO [A100+; K220; L] -	TF	N
To IBASU, turn left.	IBASU [L] -	TF	N
To VEXEL, turn left.	VEXEL [L] -	TF	N
To SAMKO at or above 4000ft, speed 190kts.	SAMKO [A040+; K190]	TF	N

Tabular Descriptions

Path Term	Waypoint Name	Fly-Over	Course °M(°T)	Distance (NM)	Turn Direction	Altitude	Speed Limit	Navigation Spec
IF	TEBUN	-	-	-	-	-	K250	RNAV1
TF	VAMPO	-	149(149.4)	19.0	L	A100+	K220	RNAV1
TF	IBASU	-	094(094.4)	9.0	L	-	-	RNAV1
TF	VEXEL	-	082(082.4)	9.0	L	-	-	RNAV1
TF	SAMKO	-	057(057.4)	12.0	-	A040+	K190	RNAV1

Radio Communications Failure Procedure

1	SET TRANSPONDER TO MODE A/C CODE 7600
2	<p>When cleared via TEBUN 1A by Singapore ATC</p> <p>(a) Maintain last assigned flight level or altitude and proceed on TEBUN 1A to SAMKO</p> <p>(b) From SAMKO commence descent and carry out appropriate landing procedure for RWY 02 as close as possible to EAT or ETA</p> <p>(c) If unable to effect a landing, refer to Singapore AIP for missed approach procedure</p>
3	<p>No clearance or instruction received from Singapore ATC</p> <p>- Refer to Singapore AIP for radio communications failure procedure</p>

**STANDARD ARRIVAL CHART
RNAV (GNSS) -
INSTRUMENT (STAR)**

ACC	133.25
APP	124.6
	119.3
TWR	118.6 / 118.25

TRANSITION ALTITUDE
11 000ft

D-ATIS AP ID-WSSS
ARR 128.025

**SINGAPORE/Singapore Changi
RWY 20R/C/L
TEBUN ONE BRAVO ARRIVAL
TEBUN 1B**

ELEV, ALT IN FEET
BEARINGS, TRACKS AND
RADIALS ARE MAGNETIC
VAR 0°23'E (2020)

DISTANCES IN NM

CAUTION: RWY 02R/20L NOT AVAILABLE FOR CIVIL USE UNTIL FURTHER ADVISED

NOTE: RADAR REQUIRED

NOTE: RNAV-1 NAVIGATION SPECIFICATION GNSS REQUIRED

NOTE: REFER TO BACK PAGE FOR
- FORMAL AND TABULAR DESCRIPTIONS
- RADIO COM FAILURE PROCEDURES

NOTE: FLIGHT PLANNING INSTRUCTIONS:
- AIRCRAFT TO FLY ARAMA DIRECT TO TEBUN
TO JOIN TEBUN 1B STAR

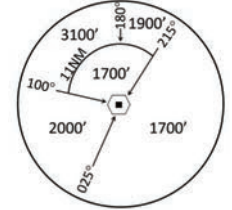

MSA 25 NM
from TEKONG DVOR

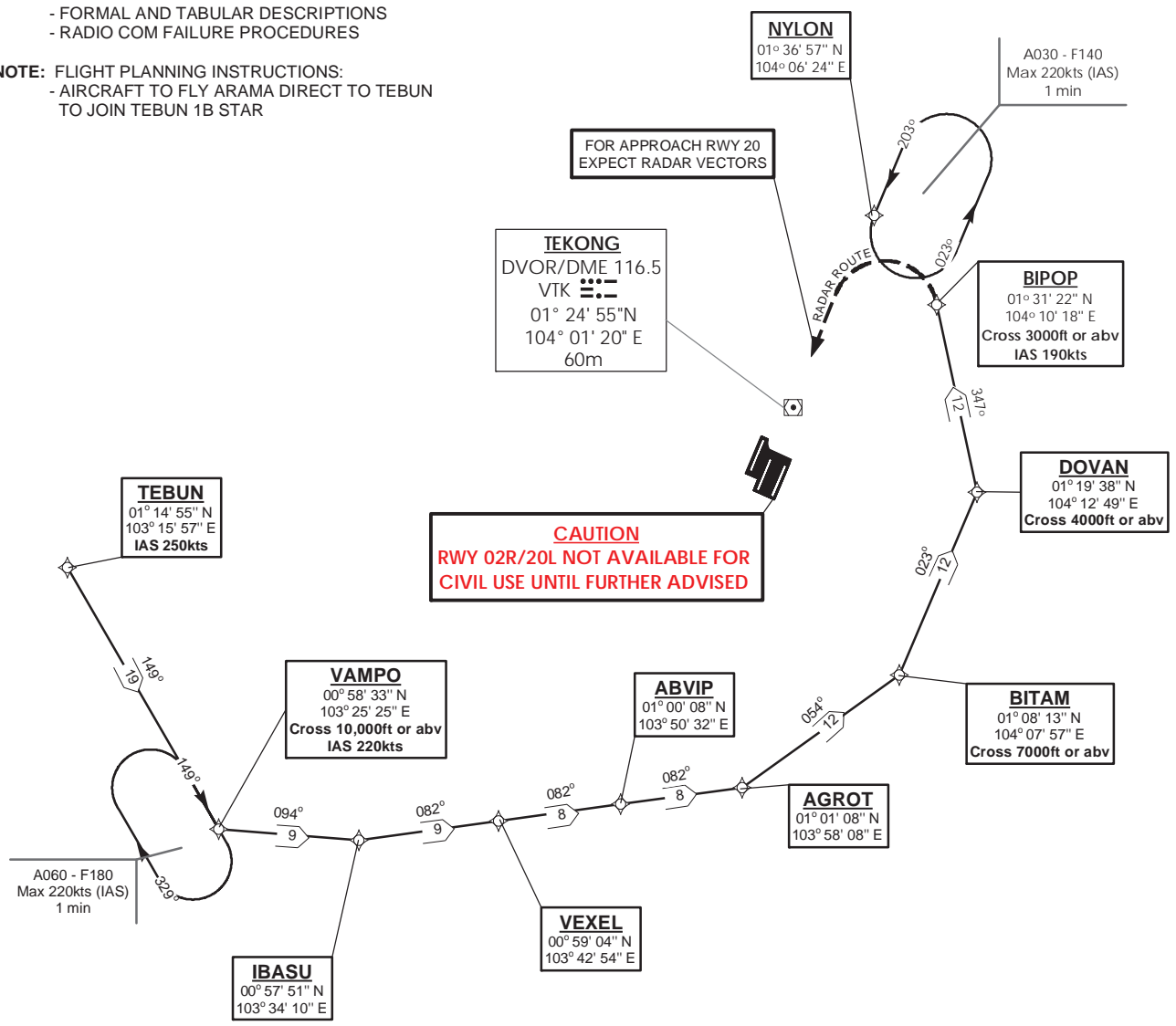

NOT TO SCALE

TEBUN 1B (STAR) RNAV GNSS RWY 20R/20C/20L - DESCRIPTIONS

Formal & Abbreviated Descriptions

Formal Description	Abbreviated Description	Path Terminator	Fly-Over required
From TEBUN, speed 250kts.	TEBUN [K250] -	IF	N
To VAMPO at or above 10000ft, speed 220kts, turn left,	VAMPO [A100+; K220; L] -	TF	N
To IBASU, turn left.	IBASU [L] -	TF	N
To VEXEL.	VEXEL -	TF	N
To ABVIP.	ABVIP -	TF	N
To AGROT, turn left.	AGROT [L] -	TF	N
To BITAM at or above 7000ft, turn left.	BITAM [A070+; L] -	TF	N
To DOVAN at or above 4000ft, turn left.	DOVAN [A040+; L] -	TF	N
To BIPOP at or above 3000ft, speed 190kts.	BIPOP [A030+; K190]	TF	N

Tabular Descriptions

Path Term	Waypoint Name	Fly-Over	Course °M(°T)	Distance (NM)	Turn Direction	Altitude	Speed Limit	Navigation Spec
IF	TEBUN	-	-	-	-	-	K250	RNAV1
TF	VAMPO	-	149(149.4)	19.0	L	A100+	K220	RNAV1
TF	IBASU	-	094(094.4)	9.0	L	-	-	RNAV1
TF	VEXEL	-	082(082.4)	9.0	-	-	-	RNAV1
TF	ABVIP	-	082(082.4)	8.0	-	-	-	RNAV1
TF	AGROT	-	082(082.4)	8.0	L	-	-	RNAV1
TF	BITAM	-	054(054.4)	12.0	L	A070+	-	RNAV1
TF	DOVAN	-	023(023.4)	12.0	L	A040+	-	RNAV1
TF	BIPOP	-	347(347.4)	12.0	-	A030+	K190	RNAV1

Radio Communications Failure Procedure

1	SET TRANSPONDER TO MODE A/C CODE 7600
2	<p>When cleared via TEBUN 1B by Singapore ATC</p> <p>(a) Maintain last assigned flight level or altitude and proceed on TEBUN 1B to BIPOP, then direct to NYLON</p> <p>(b) From NYLON commence descent and carry out appropriate landing procedure for RWY 20 as close as possible to EAT or ETA</p> <p>(c) If unable to effect a landing, refer to Singapore AIP for missed approach procedure</p>
3	No clearance or instruction received from Singapore ATC
	- Refer to Singapore AIP for radio communications failure procedure

SINGAPORE/Singapore Changi
RWY 02L/C/R
UGEBO ONE ALPHA ARRIVAL
UGEBO 1A

ACC 134.2
APP 124.05
119.3
TWR 118.6 / 118.25

D-ATIS AP ID-WSSS
128.025

TRANSITION ALTITUDE
11 000ft

STANDARD ARRIVAL CHART
RNAV (GNSS) -
INSTRUMENT (STAR)

ELEV. ALT IN FEET
BEARINGS, TRACKS AND
RADIALS ARE MAGNETIC
VAR 0°23'E (2020)

DISTANCES IN NM

CAUTION: RWY 02R/20L NOT AVAILABLE FOR CIVIL USE UNTIL FURTHER ADVISED

NOTE: RADAR REQUIRED

NOTE: RNAV-1 NAVIGATION SPECIFICATION GNSS REQUIRED

NOTE: REFER TO BACK PAGE FOR
- FORMAL AND TABULAR DESCRIPTIONS
- RADIO COM FAILURE PROCEDURES

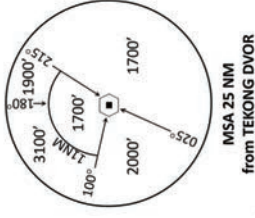

TEKONG
DVOR/DME 116.5
VTK
01° 24' 55"N
104° 01' 20" E
60m

FOR APPROACH RWY 02
EXPECT RADAR VECTORS

SAMKO
01° 05' 30" N
103° 52' 55" E

CAUTION
RWY 02R/20L NOT AVAILABLE FOR
CIVIL USE UNTIL FURTHER ADVISED

VIMAL
01° 09' 42" N
104° 23' 53" E
Cross 10000ft or abv

KEXAS
01° 10' 19" N
104° 48' 18" E
Cross F160 or b/w
IAS 220kts

GUNUD
01° 10' 42" N
105° 06' 18" E
IAS 250kts

SAMAT
01° 07' 49" N
103° 59' 30" E
Cross 4000ft or abv
IAS 190kts

IGNON
01° 08' 47" N
104° 12' 57" E
Cross 7000ft or abv

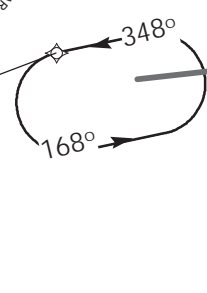

A040 - F140
Max 220kts (IAS)
1 min

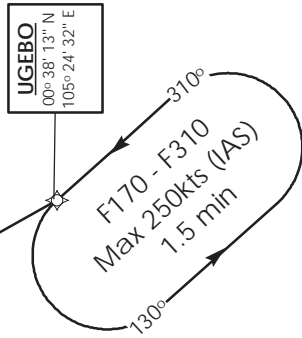

UGEBO
00° 38' 13" N
105° 24' 32" E

NOT TO SCALE

UGEBO 1A (STAR) RNAV GNSS RWY 02L/02C/02R - DESCRIPTIONS

Formal & Abbreviated Descriptions

Formal Description	Abbreviated Description	Path Terminator	Fly-Over required
From UGEBO.	UGEBO -	IF	N
To GUNUD, speed 250kts, turn left.	GUNUD [K250; L] -	TF	N
To KEXAS at or below FL160, speed 220kts.	KEXAS [FL160-; K220] -	TF	N
To VIMAL at or above 10000ft, turn left.	VIMAL [A100+; L] -	TF	N
To IGNON at or above 7000ft, turn right.	IGNON [A070+; R] -	TF	N
To SANAT at or above 4000ft, speed 190kts.	SANAT [A040+; K190]	TF	N

Tabular Descriptions

Path Term	Waypoint Name	Fly-Over	Course °M(°T)	Distance (NM)	Turn Direction	Altitude	Speed Limit	Navigation Spec
IF	UGEBO	-	-	-	-	-	-	RNAV1
TF	GUNUD	-	330(330.4)	37.0	L	-	K250	RNAV1
TF	KEXAS	-	268(268.4)	18.0	-	FL160-	K220	RNAV1
TF	VIMAL	-	268(268.4)	24.0	L	A100+	-	RNAV1
TF	IGNON	-	265(265.4)	11.0	R	A070+	-	RNAV1
TF	SANAT	-	266(266.4)	14.0	-	A040+	K190	RNAV1

Radio Communications Failure Procedure

1	SET TRANSPONDER TO MODE A/C CODE 7600
2	<p>When cleared via UGEBO 1A by Singapore ATC</p> <p>(a) Maintain last assigned flight level or altitude and proceed on UGEBO 1A to SANAT, then direct to SAMKO</p> <p>(b) From SAMKO commence descent and carry out appropriate landing procedure for RWY 02 as close as possible to EAT or ETA</p> <p>(c) If unable to effect a landing, refer to Singapore AIP for missed approach procedure</p>
3	<p>No clearance or instruction received from Singapore ATC</p> <p>- Refer to Singapore AIP for radio communications failure procedure</p>

SINGAPORE/Singapore Changi
RWY 20R/C/L
UGEBO ONE BRAVO ARRIVAL
UGEBO 1B

ACC 134.2
APP 124.05
119.3
TWR 118.6 / 118.25

TRANSITION ALTITUDE
11 000ft

D-ATIS AP ID-WSSSS
128.025

STANDARD ARRIVAL CHART
RNAV (GNSS) -
INSTRUMENT (STAR)

ELEV. ALT IN FEET
BEARINGS, TRACKS AND
RADIALS ARE MAGNETIC
VAR 0°23'E (2020)

DISTANCES IN NM

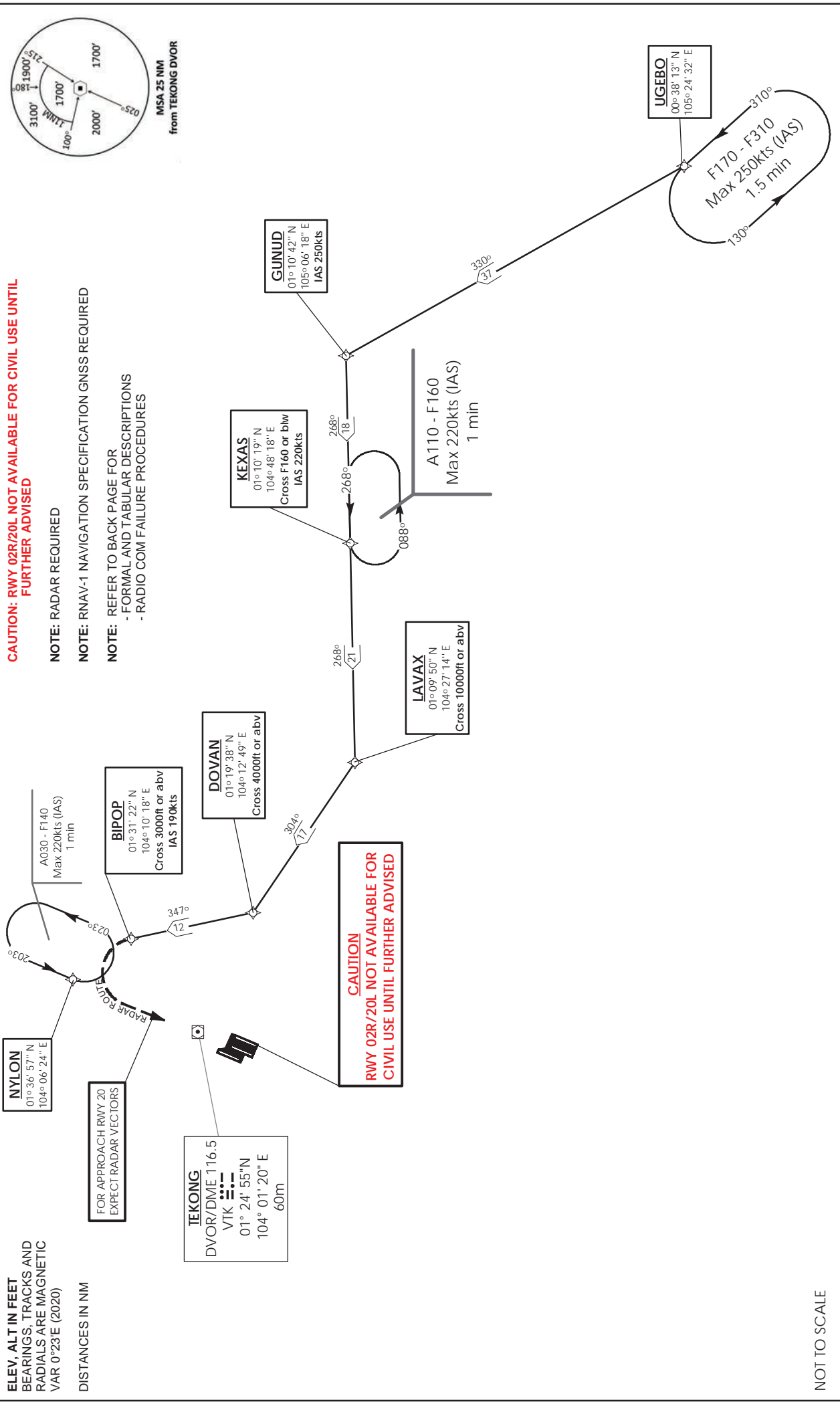

NOT TO SCALE

31 OCT 2024

UGEBO 1B (STAR) RNAV GNSS RWY 20R/20C/20L - DESCRIPTIONS**Formal & Abbreviated Descriptions**

Formal Description	Abbreviated Description	Path Terminator	Fly-Over required
From UGEB0.	UGEBO -	IF	N
To GUNUD, speed 250kts, turn left.	GUNUD [K250; L] -	TF	N
To KEXAS at or below FL160, speed 220kts.	KEXAS [FL160-; K220] -	TF	N
To LAVAX at or above 10000ft, turn right.	LAVAX [A100+; R] -	TF	N
To DOVAN at or above 4000ft, turn right.	DOVAN [A040+; R] -	TF	N
To BIPOP at or above 3000ft, speed 190kts.	BIPOP [A030+; K190]	TF	N

Tabular Descriptions

Path Term	Waypoint Name	Fly-Over	Course °M(°T)	Distance (NM)	Turn Direction	Altitude	Speed Limit	Navigation Spec
IF	UGEBO	-	-	-	-	-	-	RNAV1
TF	GUNUD	-	330(330.4)	37.0	L	-	K250	RNAV1
TF	KEXAS	-	268(268.4)	18.0	-	FL160-	K220	RNAV1
TF	LAVAX	-	268(268.4)	21.0	R	A100+	-	RNAV1
TF	DOVAN	-	304(304.4)	17.0	R	A040+	-	RNAV1
TF	BIPOP	-	347(347.4)	12.0	-	A030+	K190	RNAV1

Radio Communications Failure Procedure

1	SET TRANSPONDER TO MODE A/C CODE 7600
2	<p>When cleared via UGEB0 1B by Singapore ATC</p> <p>(a) Maintain last assigned flight level or altitude and proceed on UGEB0 1B to BIPOP, then direct to NYLON</p> <p>(b) From NYLON commence descent and carry out appropriate landing procedure for RWY 20 as close as possible to EAT or ETA</p> <p>(c) If unable to effect a landing, refer to Singapore AIP for missed approach procedure</p>
3	<p>No clearance or instruction received from Singapore ATC</p> <p>- Refer to Singapore AIP for radio communications failure procedure</p>

INSTRUMENT APPROACH CHART - ICAO

AERODROME ELEV 22ft
HEIGHT RELATED TO
THR RWY 02L - ELEV 22ft

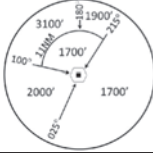

D-ATIS AP ID WSSS	128.025
APP	124.05
TWR	119.3
TWR	118.6
TWR	118.25

SINGAPORE/ SINGAPORE CHANGI ICW ILS/DME RWY 02L

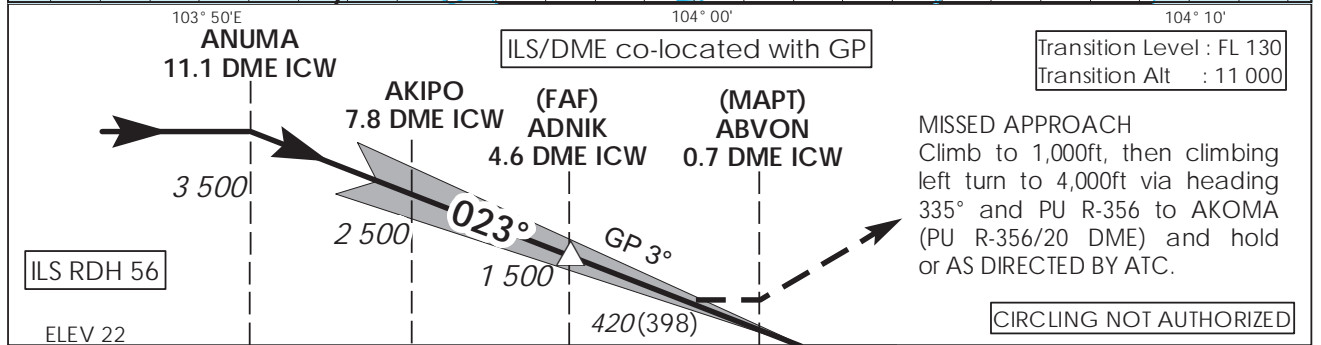
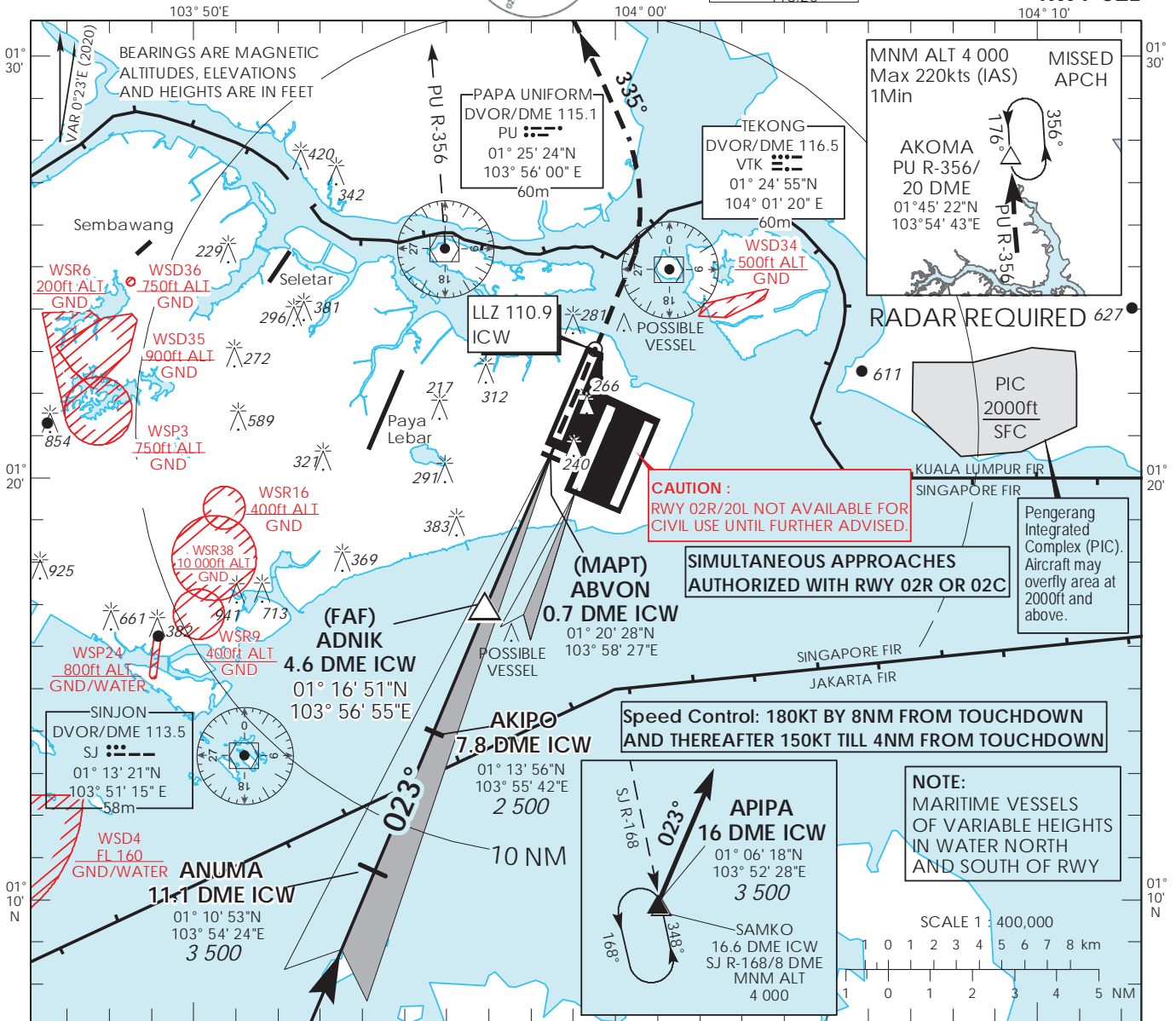

(THR RWY 02L) 10.9 10 7.6 5.4 4.4 0.5 0 NAUTICAL MILES FROM RWY THR 02L

		OCA (OCH)				
Category of Aircraft		A	B	C	D	D _L
Straight-in	CAT I ILS	173 (151)	187 (165)	203 (181)	216 (194)	219 (197)
	CAT II ILS	88 (66)	98 (76)	108 (86)	127 (105)	127 (105)
	GP INOP	420 (398)				
Distance	4 DME	3 DME		2 DME		
Altitude (Height)	1290 (1268)	970 (948)		660 (638)		
Speed	knots	70	120	150	185	
FAF - MAPT 3.9nm	min : s *	3 : 21	1 : 57	1 : 34	1 : 16	
Rate of descent/GS	ft/min	370	635	795	980	

Intentionally Left Blank

INSTRUMENT APPROACH CHART - ICAO

AERODROME ELEV 22ft
HEIGHT RELATED TO
THR RWY 02C - ELEV 16ft

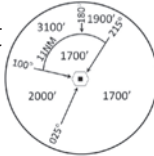

MSA 25 NM
from TEKONG DVOR

D-ATIS	AP ID WSSS
APP	128.025
TWR	124.05
	119.3
	118.6
	118.25

SINGAPORE/ SINGAPORE CHANGI ICE ILS/DME RWY 02C

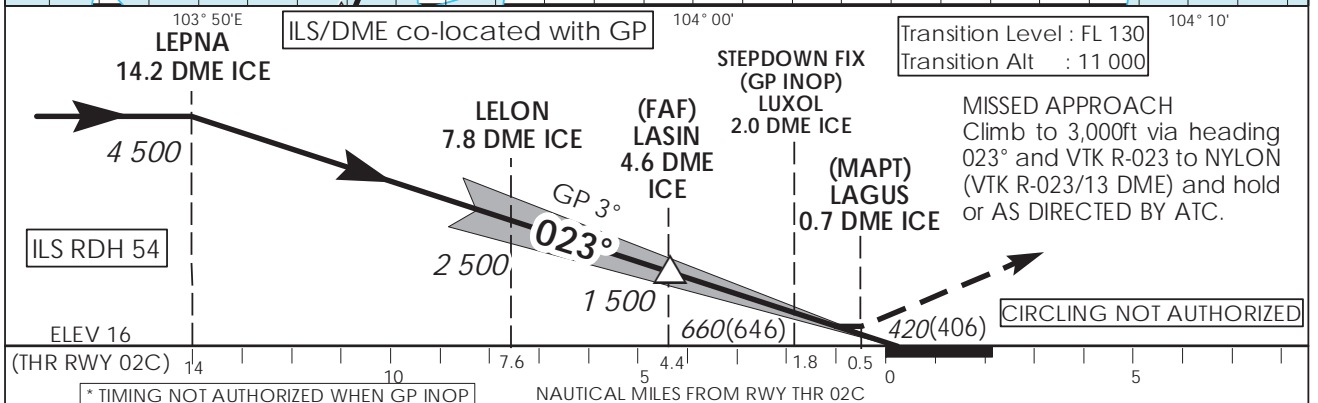
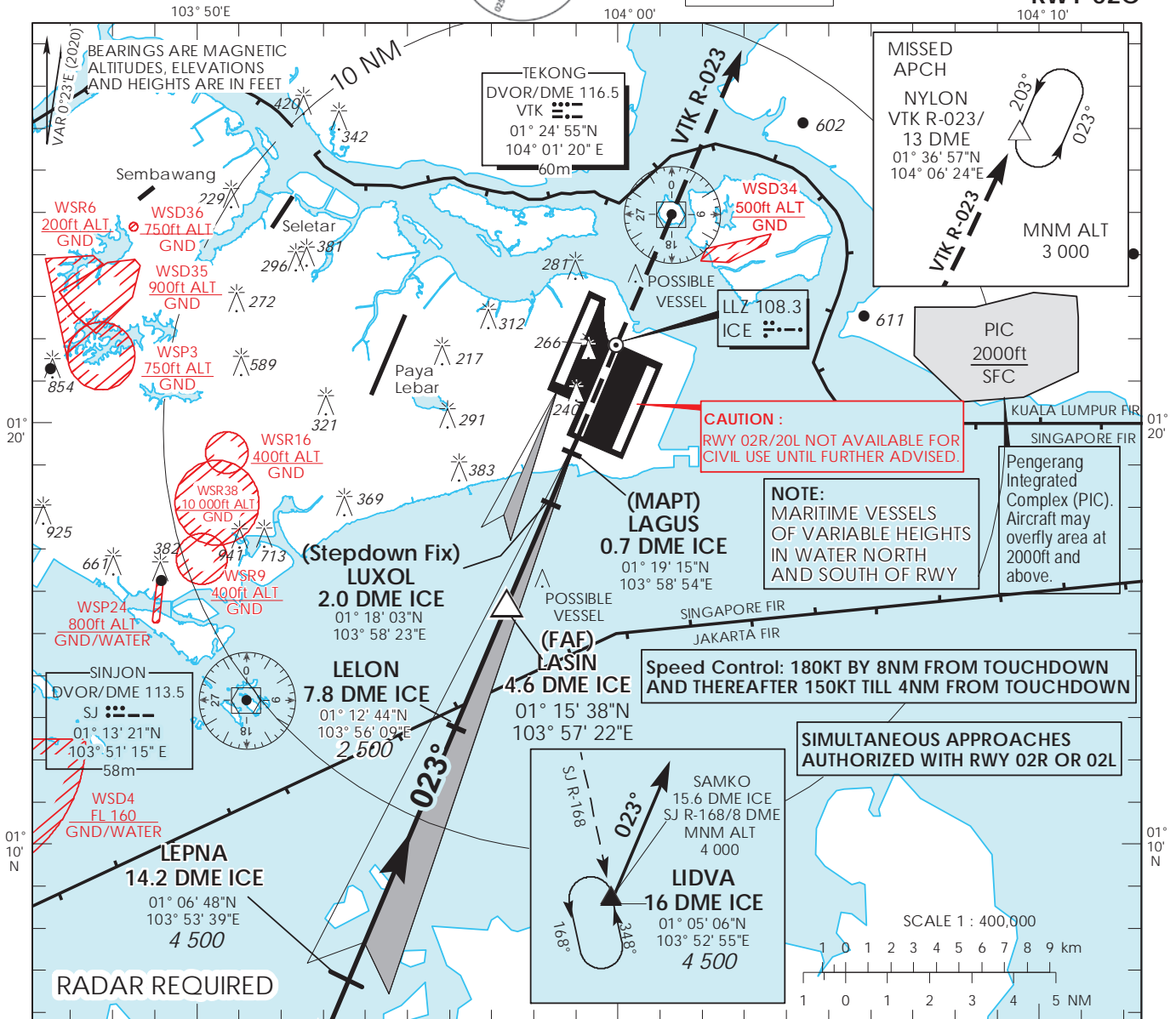

OCA (OCH)						
Category of Aircraft	A	B	C	D	D _L	
Straight-in	CAT I ILS	170 (156)	180 (166)	196 (182)	209 (195)	212 (198)
	GP INOP (with stepdown fix)	420 (406)				
	GP INOP (without stepdown fix)	660 (646)				
Distance	4 DME			3 DME		
Altitude (Height)	1290 (1276)			970 (956)		
Speed	knots	70	120	150	185	
FAF - MAPT 3.9nm	min : s*	3 : 21	1 : 57	1 : 34	1 : 16	
Rate of descent/GS	ft/min	370	635	795	980	

Intentionally Left Blank

**INSTRUMENT
APPROACH
CHART**

AERODROME ELEV 22ft
HEIGHT RELATED TO
THR RWY 02R - ELEV 16ft

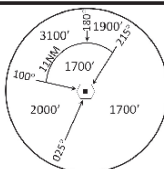

MSA 25 NM
from TEKONG DVOR

D-ATIS AP ID WSSS
128.025
APP 124.05
119.3
TWR 131.4

**SINGAPORE/
SINGAPORE CHANGI
ICX ILS/DME
RWY 02R**

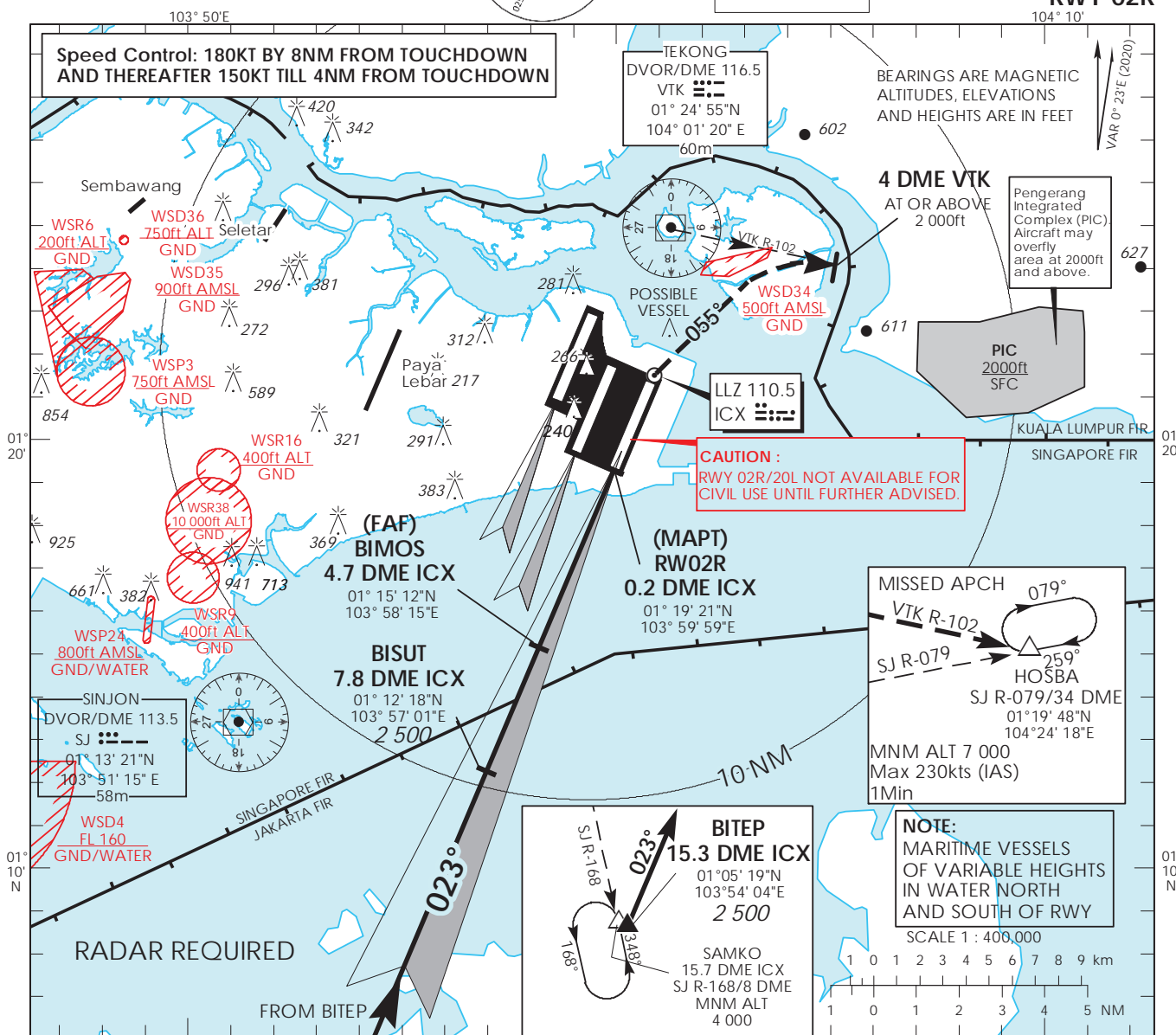

- This procedure requires a missed approach climb gradient of 5% (304 ft/NM) until passing 2,000ft. MAX IAS 185kts during turning missed approach.
- For aircraft which can only achieve a 2.5% (152 ft/NM) climb gradient, the OCA (OCH) is 820ft (800ft) and aircraft shall climb straight to 1200ft before commencing right turn climbing to 7000ft or above to HOSBA.

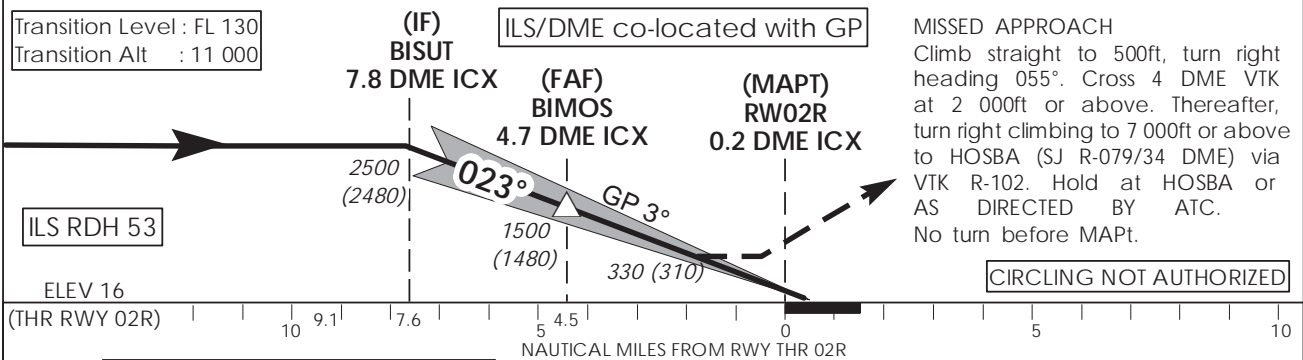

* TIMING NOT AUTHORIZED WHEN GP INOP		OCA (OCH)			
Category of Aircraft		A	B	C	D
Straight-in	CAT I ILS	220 (200)			
	CAT II ILS	120 (100)			
	GP INOP	330 (310)			
Distance	4 DME	3 DME	2 DME		
Altitude (Height)	1300 (1280)	980 (960)	660 (640)		
Speed	knots	70	120	150	185
FAF - MAPT 4.5nm	min : s *	3 : 52	2 : 15	1 : 48	1 : 28
Rate of descent/GS	ft/min	630	1080	1350	1665

Intentionally Left Blank

INSTRUMENT APPROACH CHART - ICAO

AERODROME ELEV 22ft
HEIGHT RELATED TO
DTHR RWY 20R - ELEV 13ft

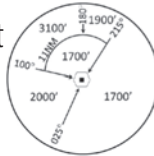

MSA 25 NM
from TEKONG DVOR

D-ATIS AP ID WSSS	128.025
APP	124.05
TWR	119.3
	118.6
	118.25

SINGAPORE/ SINGAPORE CHANGI ICH ILS/DME RWY 20R

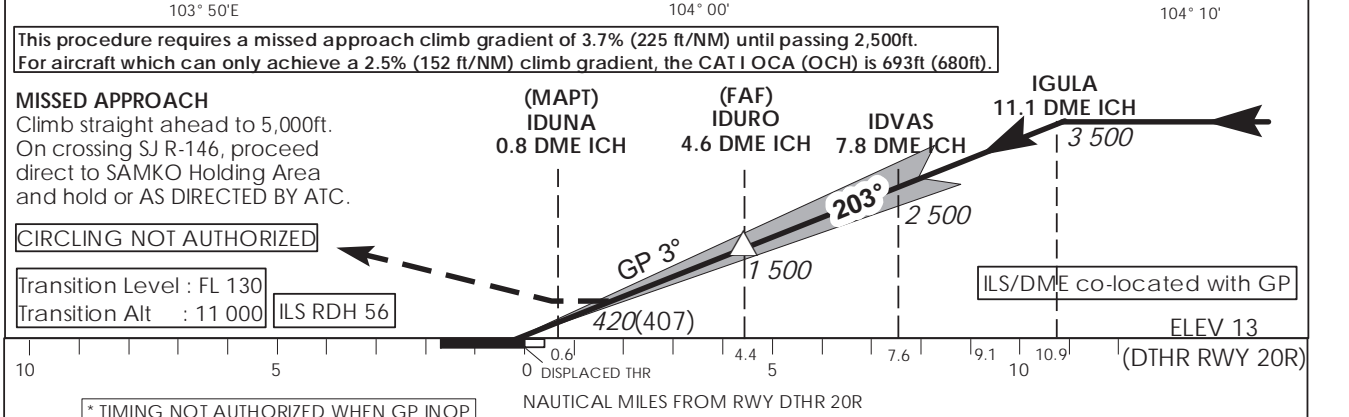
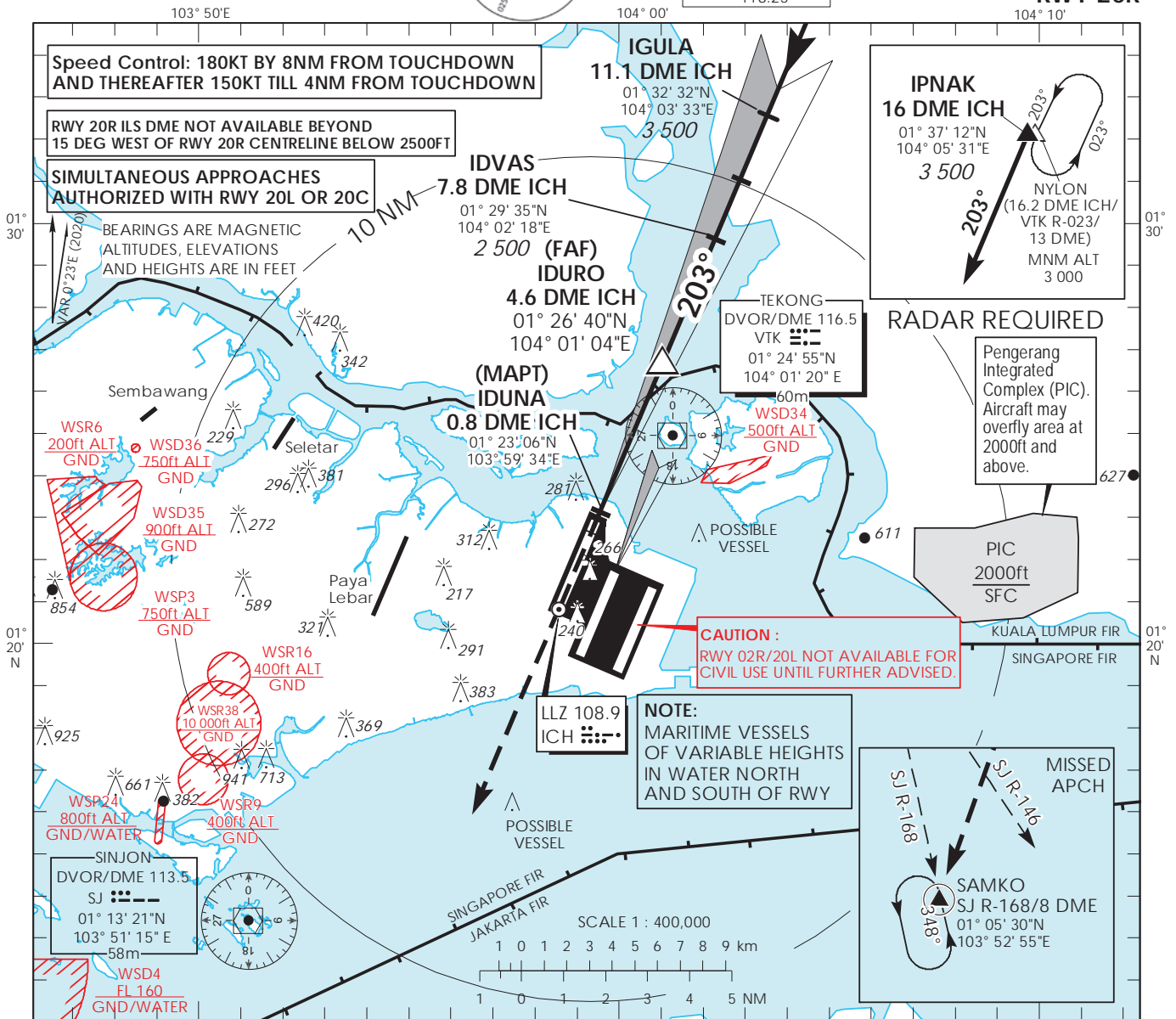

		OCA (OCH)				
Category of Aircraft		A	B	C	D	D _L
Straight-in	CAT I ILS	152 (139)	159 (146)	179 (166)	192 (179)	195 (182)
	GP INOP	420 (407)				
Distance		4 DME		3 DME		2 DME
Altitude (Height)		1290 (1277)		970 (957)		650 (637)
Speed	knots	70		120	150	185
FAF - MAPT 3.9nm	min : s *	3 : 21		1 : 57	1 : 34	1 : 16
Rate of descent/GS	ft/min	370		635	795	980

Intentionally Left Blank

Intentionally Left Blank

INSTRUMENT APPROACH CHART - ICAO

AERODROME ELEV 22ft
HEIGHT RELATED TO AD ELEV

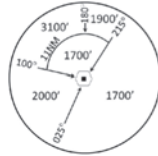

D-ATIS AP ID WSSS	128.025
APP	124.05
TWR	118.6
MIS	118.25

SINGAPORE/ SINGAPORE CHANGI VTK DVOR/DME RWY 20C

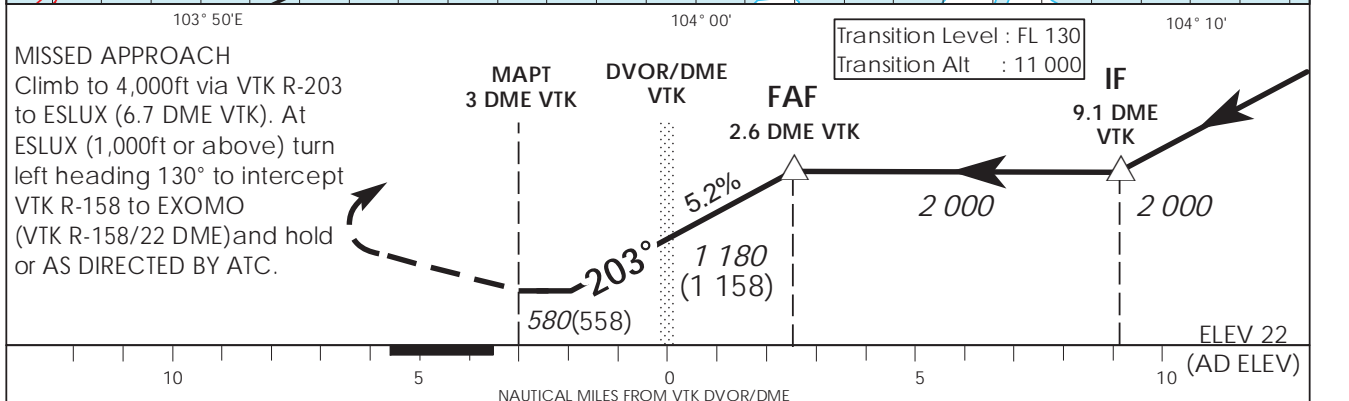
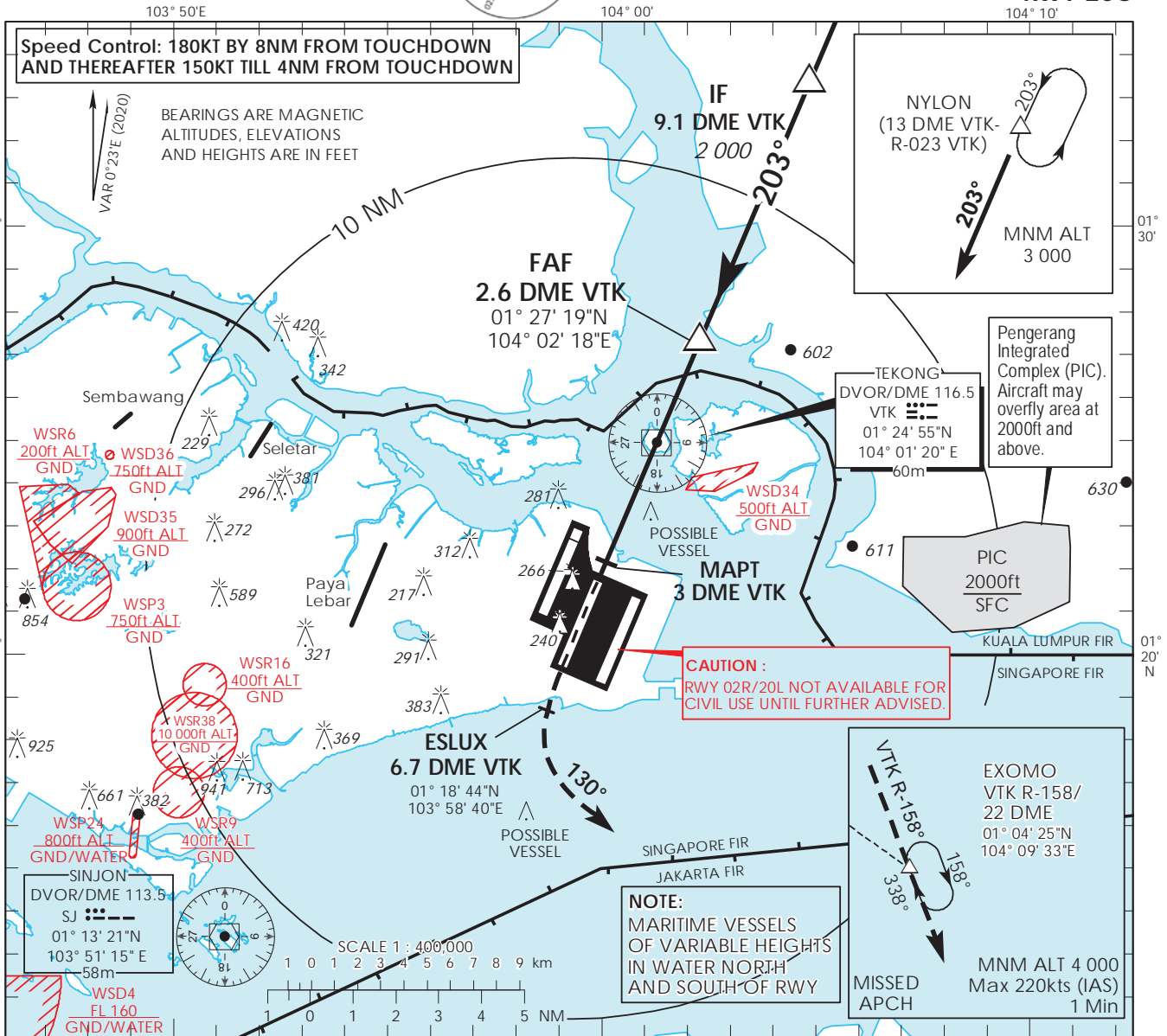

Category of Aircraft	OCA (OCH)			
	A	B	C	D
Straight-in	580 (558)			
Distance	2 DME	1 DME	VTK	1 DME
Altitude (Height)	1820 (1798)	1500 (1478)	1180 (1158)	860 (838)
Speed	knots	70	120	150
FAF - MAPT 5.6nm	min : s	4 : 48	2 : 48	2 : 15
Rate of descent/GS	ft/min	370	635	795

Intentionally Left Blank

INSTRUMENT APPROACH CHART - ICAO
AERODROME ELEV 22ft
HEIGHT RELATED TO THR RWY 02L - ELEV 22ft

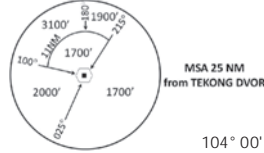

D-ATIS AP ID WSSS	128.025
APP	124.05
TWR	119.3
	118.6
	118.25

SINGAPORE/SINGAPORE CHANGI
RNP RWY 02L

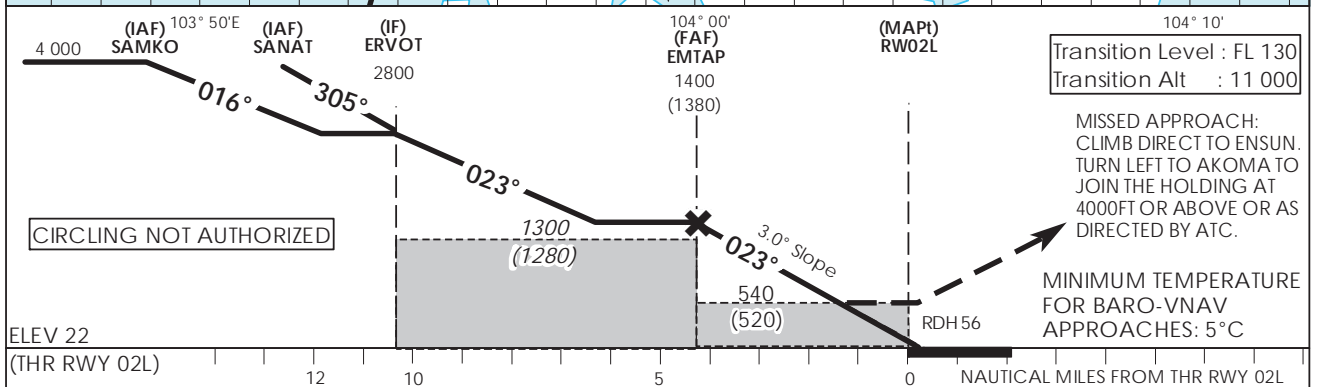
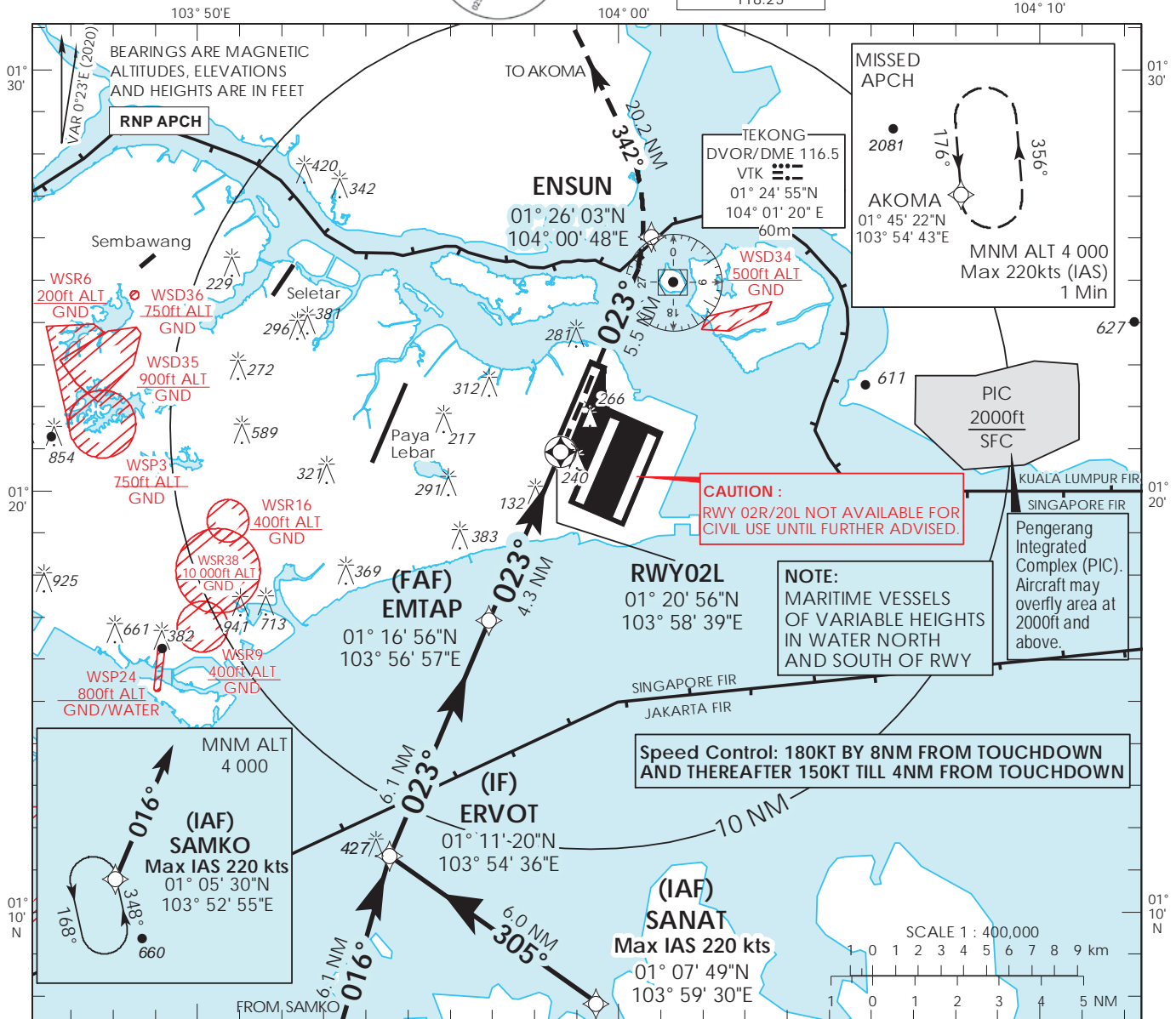

		OCA (OCH)						
Category of Aircraft		A	B	C	D			
LNAV/VNAV	2.5%	450 (430)						
LNAV	2.5%	540 (520)						
Fix		SAMKO	SANAT	ERVOT	EMTAP	RWY02L	ENSUN	AKOMA
Altitude (Height)		4000 (3978)	4000 (3978)	2800 (2778)	1400 (1378)	540 (518)	880 (858)	4000 (3978)
Speed	knots	80	100	120	140	160	180	
FAF - MAPt 4.3nm	min : s	3 : 14	2 : 35	2 : 09	1 : 51	1 : 37	1 : 26	
Rate of descent/GS	ft/min	424	530	637	743	849	955	

SINGAPORE CHANGI RNP-APCH RWY 02L – Approach from SAMKO

Path Terminator	Waypoint	Fly-Over	Course °M (°T)	Magnetic Variation	Distance (NM)	Turn Direction	Altitude (FT)	Speed Limit (KT)	VPA/TCH(FT)	Navigation Specification
IF	SAMKO	-	-	-0.4	-	-	A040+	220	-	RNP APCH
TF	ERVOT	-	016 (016.4)	-0.4	6.1	R	A028+	-	-	RNP APCH
TF	EMTAP	-	023 (023.4)	-0.4	6.1	-	A014+	-	-	RNP APCH
TF	RW02L	Y	023 (023.4)	-0.4	4.3	-	-	-	-3.0° / 50	RNP APCH
DF	ENSUN	-	-	-0.4	-	L	-	-	-	RNP APCH
TF	AKOMA	-	342 (342.4)	-0.4	20.2	-	A040+	-	-	RNP APCH

SINGAPORE CHANGI RNP-APCH RWY 02L – Approach from SANAT

Path Terminator	Waypoint	Fly-Over	Course °M (°T)	Magnetic Variation	Distance (NM)	Turn Direction	Altitude (FT)	Speed Limit (KT)	VPA/TCH(FT)	Navigation Specification
IF	SANAT	-	-	-0.4	-	-	A040+	220	-	RNP APCH
TF	ERVOT	-	305 (305.4)	-0.4	6.0	R	A028+	-	-	RNP APCH
TF	EMTAP	-	023 (023.4)	-0.4	6.1	-	A014+	-	-	RNP APCH
TF	RW02L	Y	023 (023.4)	-0.4	4.3	-	-	-	-3.0° / 50	RNP APCH
DF	ENSUN	-	-	-0.4	-	L	-	-	-	RNP APCH
TF	AKOMA	-	342 (342.4)	-0.4	20.2	-	A040+	-	-	RNP APCH

Waypoint Coordinates

Name	Latitude	Longitude
SAMKO (IAF)	01° 05' 30" N	103° 52' 55" E
SANAT (IAF)	01° 07' 49" N	103° 59' 30" E
ERVOT (IF)	01° 11' 20" N	103° 54' 36" E
EMTAP (FAF)	01° 16' 56" N	103° 56' 57" E
RW02L	01° 20' 56" N	103° 58' 39" E
ENSUN	01° 26' 03" N	104° 00' 48" E
AKOMA	01° 45' 22" N	103° 54' 43" E

SINGAPORE CHANGI RNP-APCH RWY 02C – Approach from SAMKO

Path Terminator	Waypoint	Fly-Over	Course °M (°T)	Magnetic Variation	Distance (NM)	Turn Direction	Altitude (FT)	Speed Limit (KT)	VPA/TCH(FT)	Navigation Specification
IF	SAMKO	-	-	-0.4	-	-	A040+	220	-	RNP APCH
TF	KIMER	-	024 (024.4)	-0.4	6.1	-	A020+	-	-	RNP APCH
TF	KASPO	-	023 (023.4)	-0.4	4.4	-	A016+	-	-	RNP APCH
TF	KAKSA	-	023 (023.4)	-0.4	2.1	-	990ft+	-	-	RNP APCH
TF	RW02C	Y	023 (023.4)	-0.4	2.9	-	-	-	-3.0° / 50	RNP APCH
DF	NYLON	-	-	-0.4	-	-	A030+	-	-	RNP APCH

Waypoint Coordinates

Name	Latitude	Longitude
SAMKO (IAF)	01° 05' 30" N	103° 52' 55" E
KIMER (IF)	01° 11' 06" N	103° 55' 27" E
KASPO (FAF)	01° 15' 07" N	103° 57' 09" E
KAKSA (SDF)	01° 17' 03" N	103° 57' 58" E
RW02C	01° 19' 44" N	103° 59' 06" E
NYLON	01° 36' 57" N	104° 06' 24" E

INSTRUMENT APPROACH CHART - ICAO

AERODROME ELEV 22ft
HEIGHT RELATED TO
DTHR RWY 20R - ELEV 13ft

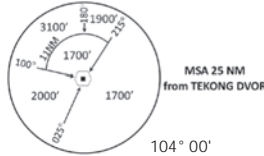

D-ATIS AP ID WSSS	128.025
APP	124.05
	119.3
TWR	118.6
	118.25

SINGAPORE/ SINGAPORE CHANGI RNP RWY 20R

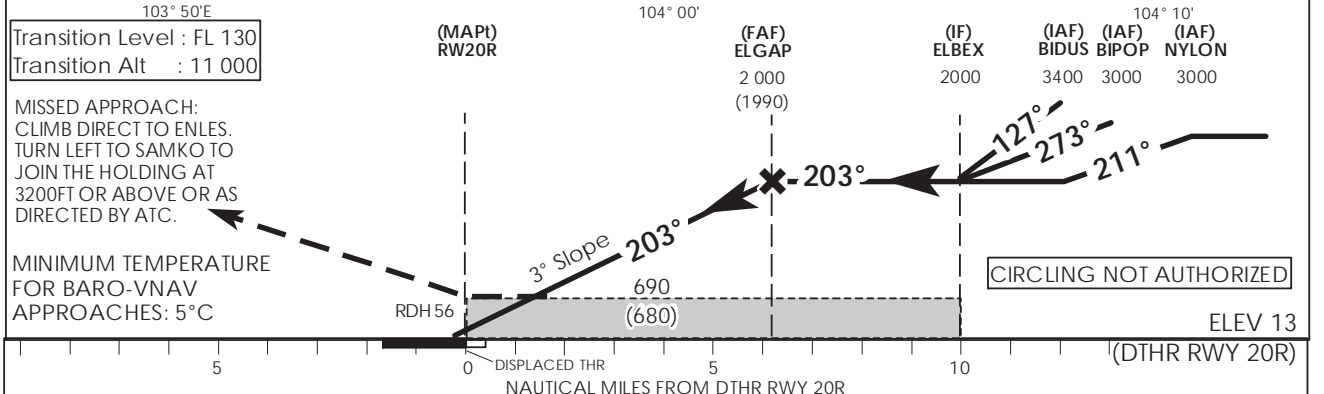
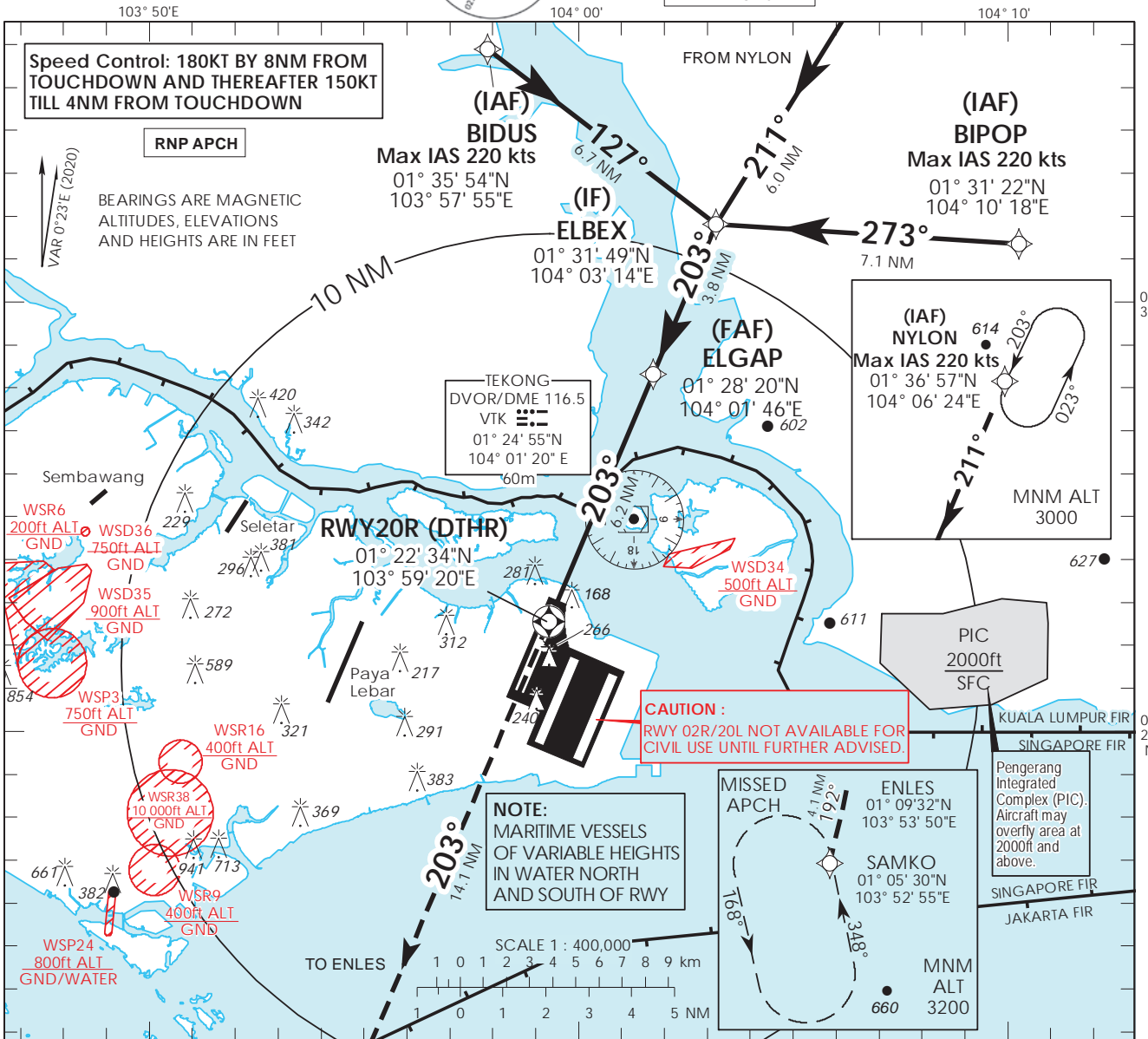

		OCA (OCH)							
		A	B	C	D				
Category of Aircraft									
LNAV/VNAV	2.5%	690 (680)							
LNAV	2.5%	690 (680)							
Fix		BIDUS	NYLON	BIPOP	ELBEX	ELGAP	RW20R	ENLES	SAMKO
Altitude (Height)		3400 (3387)	3000 (2987)	3000 (2987)	2000 (1987)	2000 (1987)	690 (680)	2180 (2167)	3200 (3187)
Speed	knots	80	100	120	140	160	180		
FAF - MAPT 6.2 nm	min : s	4 : 39	3 : 44	3 : 06	2 : 40	2 : 20	2 : 04		
Rate of descent/GS	ft/min	425	531	637	743	849	955		

SINGAPORE CHANGI RNP-APCH RWY 20R – Approach from BIDUS

Path Terminator	Waypoint	Fly-Over	Course °M (°T)	Magnetic Variation	Distance (NM)	Turn Direction	Altitude (FT)	Speed Limit (KT)	VPA/TCH(FT)	Navigation Specification
IF	BIDUS	-	-	-0.4	-	-	A034+	220	-	RNP APCH
TF	ELBEX	-	127 (127.4)	-0.4	6.7	R	A020+	-	-	RNP APCH
TF	ELGAP	-	203 (203.4)	-0.4	3.8	-	A020+	-	-	RNP APCH
TF	RW20R	Y	203 (203.4)	-0.4	6.2	-	-	-	-3.0° / 50	RNP APCH
DF	ENLES	-	-	-0.4	-	L	-	-	-	RNP APCH
TF	SAMKO	-	192 (192.4)	-0.4	4.1	-	A032+	-	-	RNP APCH

SINGAPORE CHANGI RNP-APCH RWY 20R – Approach from NYLON

Path Terminator	Waypoint	Fly-Over	Course °M (°T)	Magnetic Variation	Distance (NM)	Turn Direction	Altitude (FT)	Speed Limit (KT)	VPA/TCH(FT)	Navigation Specification
IF	NYLON	-	-	-0.4	-	-	A030+	220	-	RNP APCH
TF	ELBEX	-	211 (211.4)	-0.4	6.0	L	A020+	-	-	RNP APCH
TF	ELGAP	-	203 (203.4)	-0.4	3.8	-	A020+	-	-	RNP APCH
TF	RW20R	Y	203 (203.4)	-0.4	6.2	-	-	-	-3.0° / 50	RNP APCH
DF	ENLES	-	-	-0.4	-	L	-	-	-	RNP APCH
TF	SAMKO	-	192 (192.4)	-0.4	4.1	-	A032+	-	-	RNP APCH

SINGAPORE CHANGI RNP-APCH RWY 20R – Approach from BIPOP

Path Terminator	Waypoint	Fly-Over	Course °M (°T)	Magnetic Variation	Distance (NM)	Turn Direction	Altitude (FT)	Speed Limit (KT)	VPA/TCH(FT)	Navigation Specification
IF	BIPOP	-	-	-0.4	-	-	A030+	220	-	RNP APCH
TF	ELBEX	-	273 (273.4)	-0.4	7.1	L	A020+	-	-	RNP APCH
TF	ELGAP	-	203 (203.4)	-0.4	3.8	-	A020+	-	-	RNP APCH
TF	RW20R	Y	203 (203.4)	-0.4	6.2	-	-	-	-3.0° / 50	RNP APCH
DF	ENLES	-	-	-0.4	-	L	-	-	-	RNP APCH
TF	SAMKO	-	192 (192.4)	-0.4	4.1	-	A032+	-	-	RNP APCH

Waypoint Coordinates

Name	Latitude	Longitude
BIDUS (IAF)	01° 35' 54" N	103° 57' 55" E
NYLON (IAF)	01° 36' 57" N	104° 06' 24" E
BIPOP (IAF)	01° 31' 22" N	104° 10' 18" E
ELBEX (IF)	01° 31' 49" N	104° 03' 14" E
ELGAP (FAF)	01° 28' 20" N	104° 01' 46" E
RW20R	01° 22' 34" N	103° 59' 20" E
ENLES	01° 09' 32" N	103° 53' 50" E
SAMKO	01° 05' 30" N	103° 52' 55" E

INSTRUMENT APPROACH CHART - ICAO

AERODROME ELEV 22ft
HEIGHT RELATED TO
THR RWY 20C - ELEV 16ft

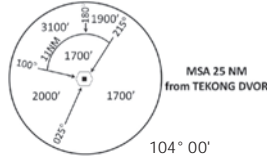

D-ATIS AP ID WSSS	128.025
APP	124.05
	119.3
TWR	118.6
	118.25

SINGAPORE/SINGAPORE CHANGI RNP RWY 20C

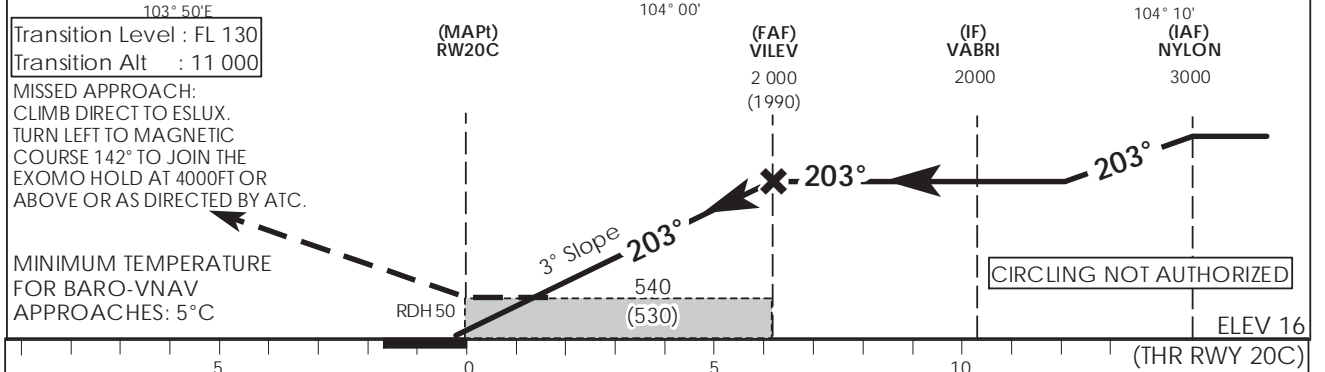
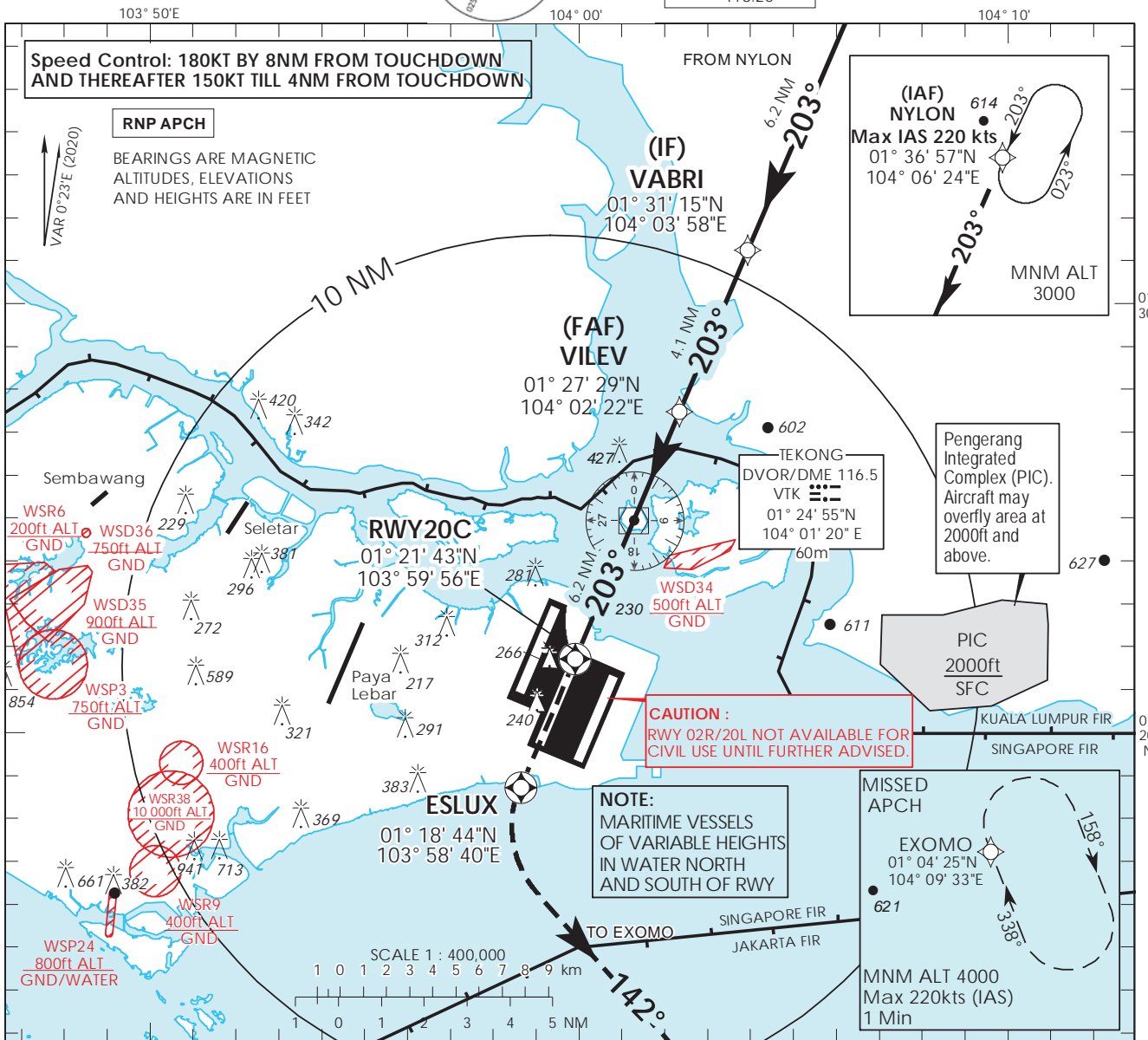

		OCA (OCH)					
Category of Aircraft		A	B	C	D		
LNAV/VNAV	2.5%	490 (480)					
LNAV	2.5%	540 (530)					
Fix		NYLON	VABRI	VILEV	RW20C	ESLUX	EXOMO
Altitude (Height)		3000 (2985)	2000 (1985)	2000 (1985)	540 (525)	540 (525)	4000 (3985)
Speed	knots	80	100	120	140	160	180
FAF - MAPt 6.2 nm	min : s	4 : 39	3 : 44	3 : 06	2 : 40	2 : 20	2 : 04
Rate of descent/GS	ft/min	425	531	637	743	849	955

SINGAPORE CHANGI RNP-APCH RWY 20C – Approach from NYLON

Path Terminator	Waypoint	Fly-Over	Course °M (°T)	Magnetic Variation	Distance (NM)	Turn Direction	Altitude (FT)	Speed Limit (KT)	VPA/TCH(FT)	Navigation Specification
IF	NYLON	-	-	-0.4	-	-	A030+	220	-	RNP APCH
TF	VABRI	-	203 (203.4)	-0.4	6.2	-	A020+	-	-	RNP APCH
TF	VILEV	-	203 (203.4)	-0.4	4.1	-	A020+	-	-	RNP APCH
TF	RW20C	Y	203 (203.4)	-0.4	6.2	-	-	-	-3.0° / 50	RNP APCH
DF	ESLUX	Y	-	-0.4	-	L	-	-	-	RNP APCH
TF	EXOMO	-	142 (142.4)	-0.4	-	-	A040+	-	-	RNP APCH

Waypoint Coordinates

Name	Latitude	Longitude
NYLON (IAF)	01° 36' 57" N	104° 06' 24" E
VABRI (IF)	01° 31' 15" N	104° 03' 58" E
VILEV (FAF)	01° 27' 29" N	104° 02' 22" E
RW20C	01° 21' 43" N	103° 59' 56" E
ESLUX	01° 18' 44" N	103° 58' 40" E
EXOMO	01° 04' 25" N	104° 09' 33" E

**INSTRUMENT
APPROACH
CHART**

AERODROME ELEV 22ft
HEIGHT RELATED TO
THR RWY 02R - ELEV 16ft

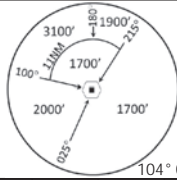

MSA 25 NM
from TEKONG DVOR

D-ATIS	AP ID WSSS
APP	128.025
	124.05
	119.3
TWR	131.4

**SINGAPORE/
SINGAPORE CHANGI
RNP RWY 02R**

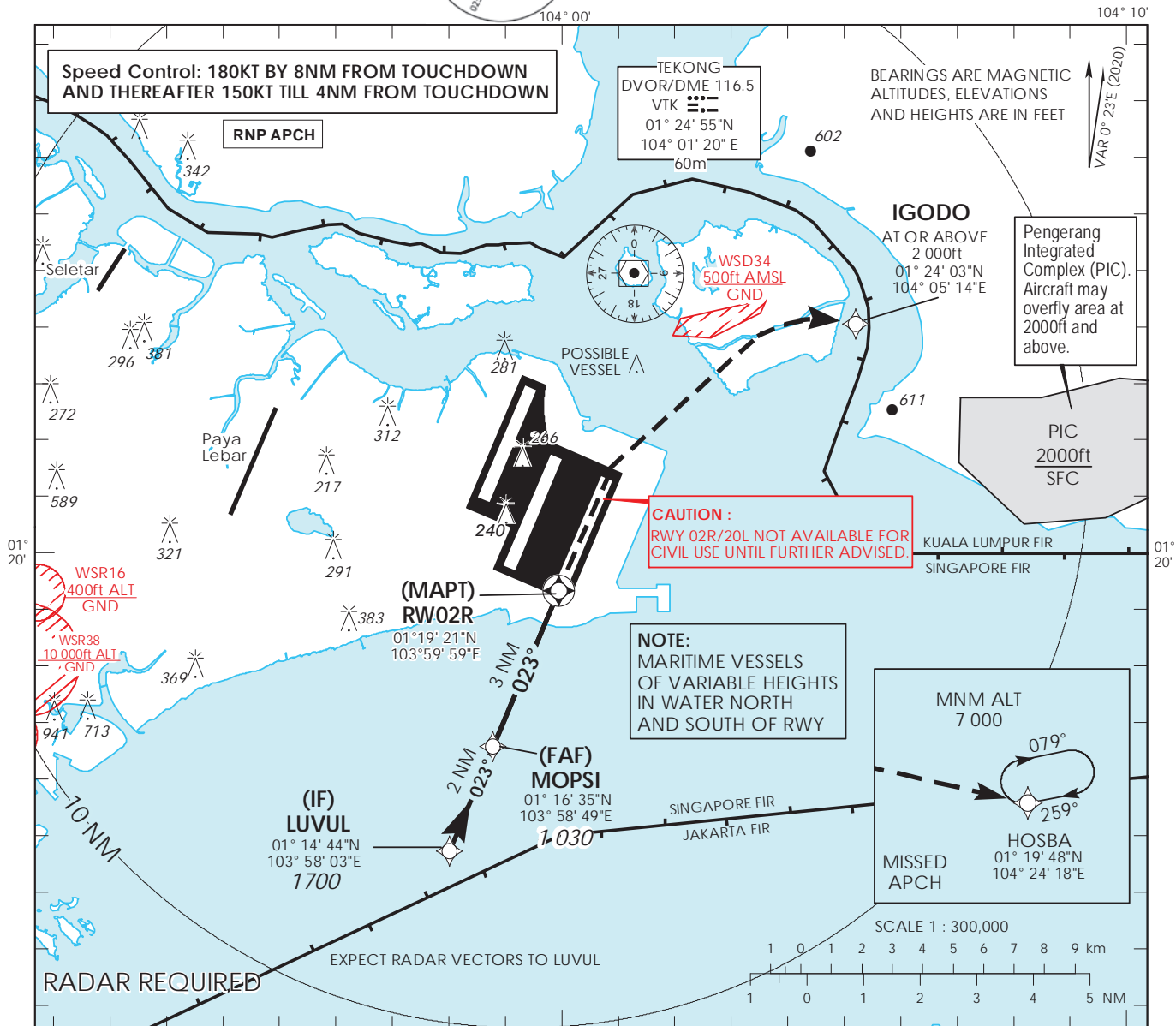

- This procedure requires a missed approach climb gradient of 5% (304 ft/NM) until passing 2,000ft. MAX IAS 185kts during turning missed approach.
- For aircraft which can only achieve a 2.5% (152 ft/NM) climb gradient, the OCA (OCH) is 820ft (800ft) and aircraft shall climb straight to 1200ft before commencing right turn climbing to 7000ft or above to HOSBA.

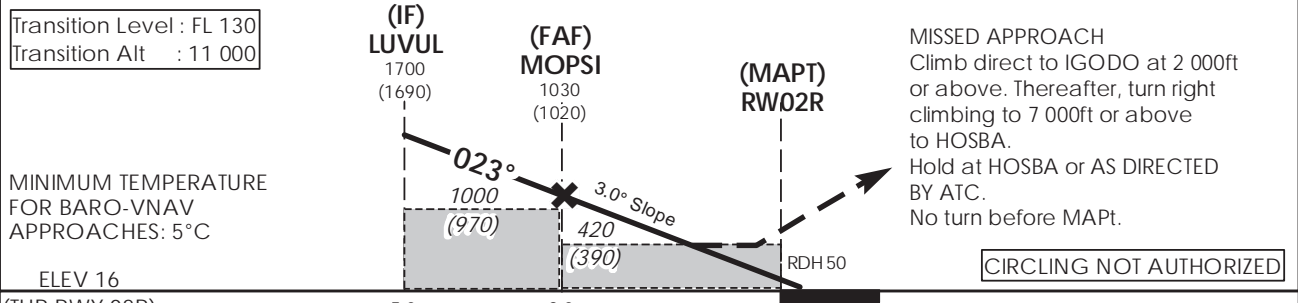

Transition Level : FL 130
Transition Alt : 11 000

MINIMUM TEMPERATURE FOR BARO-VNAV APPROACHES: 5°C

ELEV 16 (THR RWY 02R)

NAUTICAL MILES FROM RWY THR 02R

Category of Aircraft	OCA (OCH)				
	A	B	C	D	
LNAV/VNAV	5%	330 (310)			
LNAV	5%	420 (390)			
Distance	LUVUL		MOPSI		
Altitude (Height)	1700 (1690)		1030 (1020)		
Speed	knots	70	120	150	185
FAF - MAPt 3.0nm	min : s *	2 : 34	1 : 30	1 : 12	0 : 58
Rate of descent/GS	ft/min	370	635	795	980

SINGAPORE CHANGI RNP-APCH RWY 02R – Approach from LUVUL

Path Terminator	Waypoint	Fly-Over	Course °M (°T)	Magnetic Variation	Distance (NM)	Turn Direction	Altitude (FT)	Speed Limit (KT)	VPA/TCH(FT)	Navigation Specification
IF	LUVUL	-	023 (023.4)	-0.4	-	-	1700+	180	-	RNP APCH
TF	MOPSI	-	023 (023.4)	-0.4	2.0	-	1030+	150	-	RNP APCH
TF	RW02R	Y	023 (023.4)	-0.4	3.0	R	-	-	-3.0° / 50	RNP APCH
DF	IGODO	-	-	-0.4	-	R	2000+	185	-	RNP APCH
TF	HOSBA	-	103 (103.4)	-0.4	-	-	7000+	-	-	RNP APCH

Waypoint Coordinates

Name	Latitude	Longitude
LUVUL (IF)	01° 14' 44" N	103° 58' 03" E
MOPSI (FAF)	01° 16' 35" N	103° 58' 49" E
RW02R	01° 19' 21" N	103° 59' 59" E
IGODO	01° 24' 03" N	104° 05' 14" E
HOSBA	01° 19' 48" N	104° 24' 18" E

INSTRUMENT APPROACH CHART
AERODROME ELEV 22ft
HEIGHT RELATED TO
THR RWY 20L - ELEV 16ft

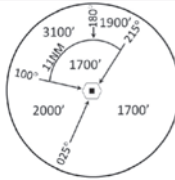

MSA 25 NM
from TEKONG DVOR

D-ATIS	AP ID	WSSS
APP	128.6	124.05
TWR	119.3	131.4

**SINGAPORE/
SINGAPORE CHANGI**
RNP RWY 20L

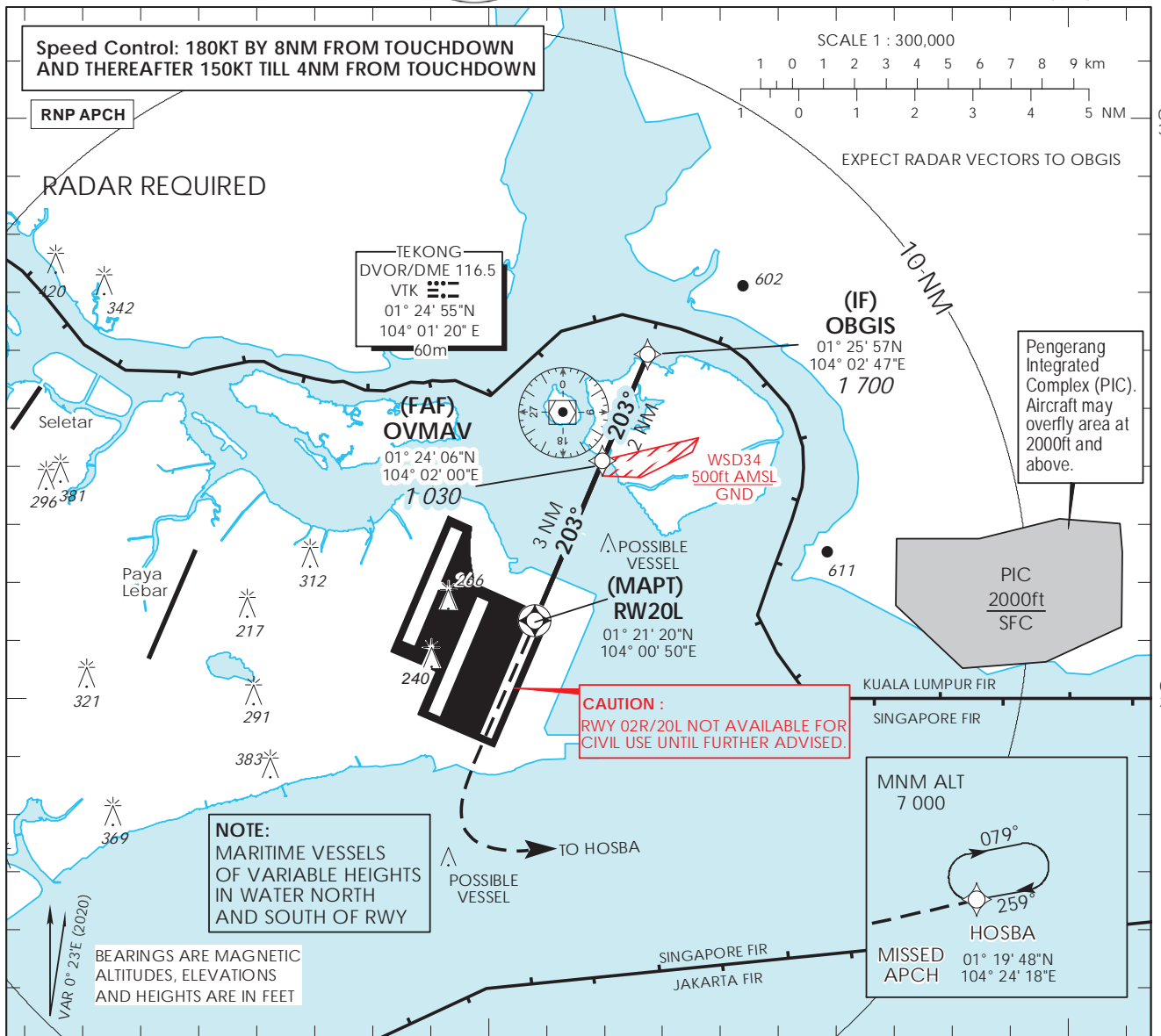

This procedure requires a missed approach climb gradient of 5% (304 ft/NM) until passing 3,000ft.
For aircraft which can only achieve a 2.5% (152 ft/NM) climb gradient, the OCA (OCH) is 1080ft (1050ft).

Transition Level : FL 130
Transition Alt : 11 000

MISSED APPROACH
Climb straight to 1 500ft, turn left climbing to 7 000ft or above to HOSBA.
Hold at HOSBA or AS DIRECTED BY ATC.
No turn before MAPt.

CIRCLING NOT AUTHORIZED

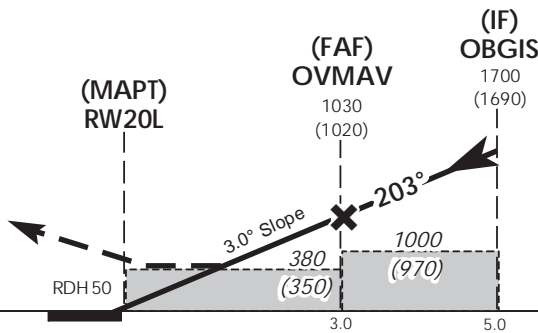

MINIMUM TEMPERATURE FOR BARO-VNAV APPROACHES: 5°C

		OCA (OCH)			
Category of Aircraft		A	B	C	D
LNAV/VNAV	5%	280 (260)			
LNAV	5%	380 (350)			
Distance		OBGIS		OVMAV	
Altitude (Height)		1700 (1690)		1030 (1020)	
Speed	knots	70	120	150	185
FAF - MAPt 3.0nm	min : s *	2 : 34	1 : 30	1 : 12	0 : 58
Rate of descent/GS	ft/min	370	635	795	980

SINGAPORE CHANGI RNP-APCH RWY 20L – Approach from OBGIS

Path Terminator	Waypoint	Fly-Over	Course °M (°T)	Magnetic Variation	Distance (NM)	Turn Direction	Altitude (FT)	Speed Limit (KT)	VPA/TCH(FT)	Navigation Specification
IF	OBGIS	-	203 (203.4)	-0.4	-	-	1700+	180	-	RNP APCH
TF	OVMAN	-	203 (203.4)	-0.4	2.0	-	1030+	150	-	RNP APCH
TF	RW20L	Y	203 (203.4)	-0.4	3.0	-	-	-	-3.0° / 50	RNP APCH
CA	-	-	203 (203.4)	-0.4	-	L	1500+	-	-	RNP APCH
DF	HOSBA	-	-	-	-	-	7000+	-	-	RNP APCH

Waypoint Coordinates

Name	Latitude	Longitude
OBGIS (IF)	01° 25' 57" N	104° 02' 47" E
OVMAN (FAF)	01° 24' 06" N	104° 02' 00" E
RW20L	01° 21' 20" N	104° 00' 50" E
HOSBA	01° 19' 48" N	104° 24' 18" E

**VISUAL
APPROACH
CHART - ICAO**

AERODROME ELEV 22 ft

D-ATIS	AP ID WSSS
APP	128.025
TWR	124.05
	119.3
	118.6
	118.25

SINGAPORE/SINGAPORE CHANGI

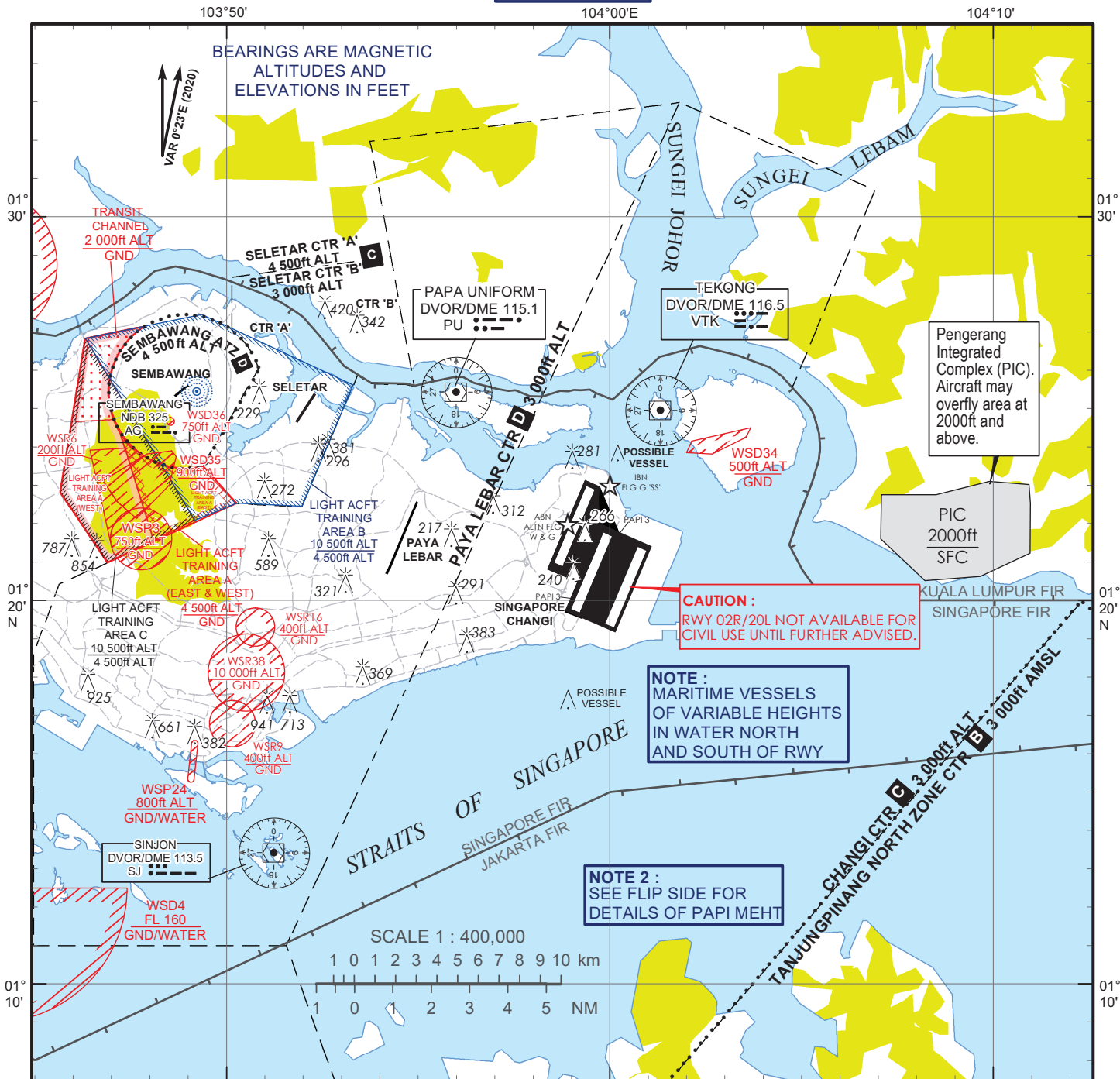

VISUAL APPROACH PROCEDURE

1. An IFR flight operating into Singapore Changi Airport may be cleared for a visual approach subject to the following conditions :-
 - a) The pilot has the aerodrome in sight and can conduct his approach with visual reference to terrain;
 - b) The flight will not cause delay to other traffic;
 - c) There is no conflicting tall vessel movement;
 - d) The cloud ceiling at the aerodrome is 4,000ft or more for landing on RWY 20C/R/L and 3,000ft or more for on RWY 02C/L/R ; and
 - e) The visibility at the aerodrome is 5km or more.
2. Notwithstanding para 1d) and 1e), if the pilot reports that he has the aerodrome in sight and can conduct his approach with visual reference to terrain, the flight may be cleared for a visual approach.
3. Pilots may expect radar vectoring for separation and sequencing with other traffic prior to being cleared for a visual approach.

PAPI 3° (MEHT)*						
Pilot's eye height over the threshold when the following PAPI lights come in view.	RUNWAY					
	02L	20R	02C	20C	02R	20L
2 White lights and 2 Red lights	20.0m	19.5m	19.8m	19.8m	19.7m	19.7m
3 White lights and 1 Red light	24.0m	23.3m	23.7m	23.7m	23.6m	23.6m
4 White lights	26.4m	25.7m	26.2m	26.2m	26.0m	26.0m
<p>*MEHT : Minimum Eye Height Over the Threshold.</p> <p>Note : Aircraft with eye-to-wheel height greater than 8 meters are advised to fly with 2 white lights and 2 red lights visible so as to achieve sufficient wheel clearance.</p>						